

STERN Pinball
 2001 Lunt Ave
 Elk Grove, Ill 60007
 708-345-7700

TITLE: 520-7014-00A

Document Number: CPU
 Date: 10/5/18 1:25 PM

REU:
 Sheet: 1/9

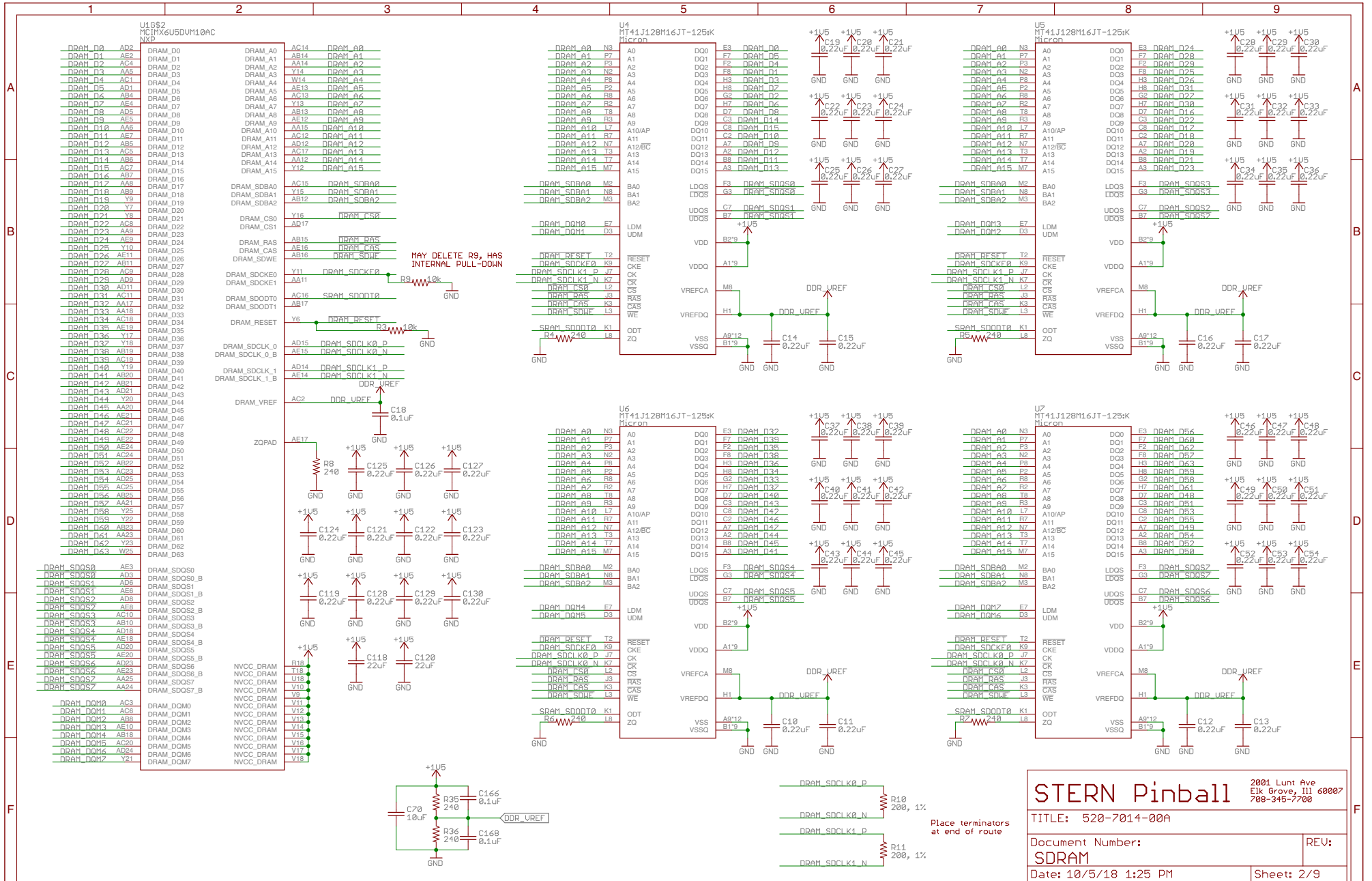

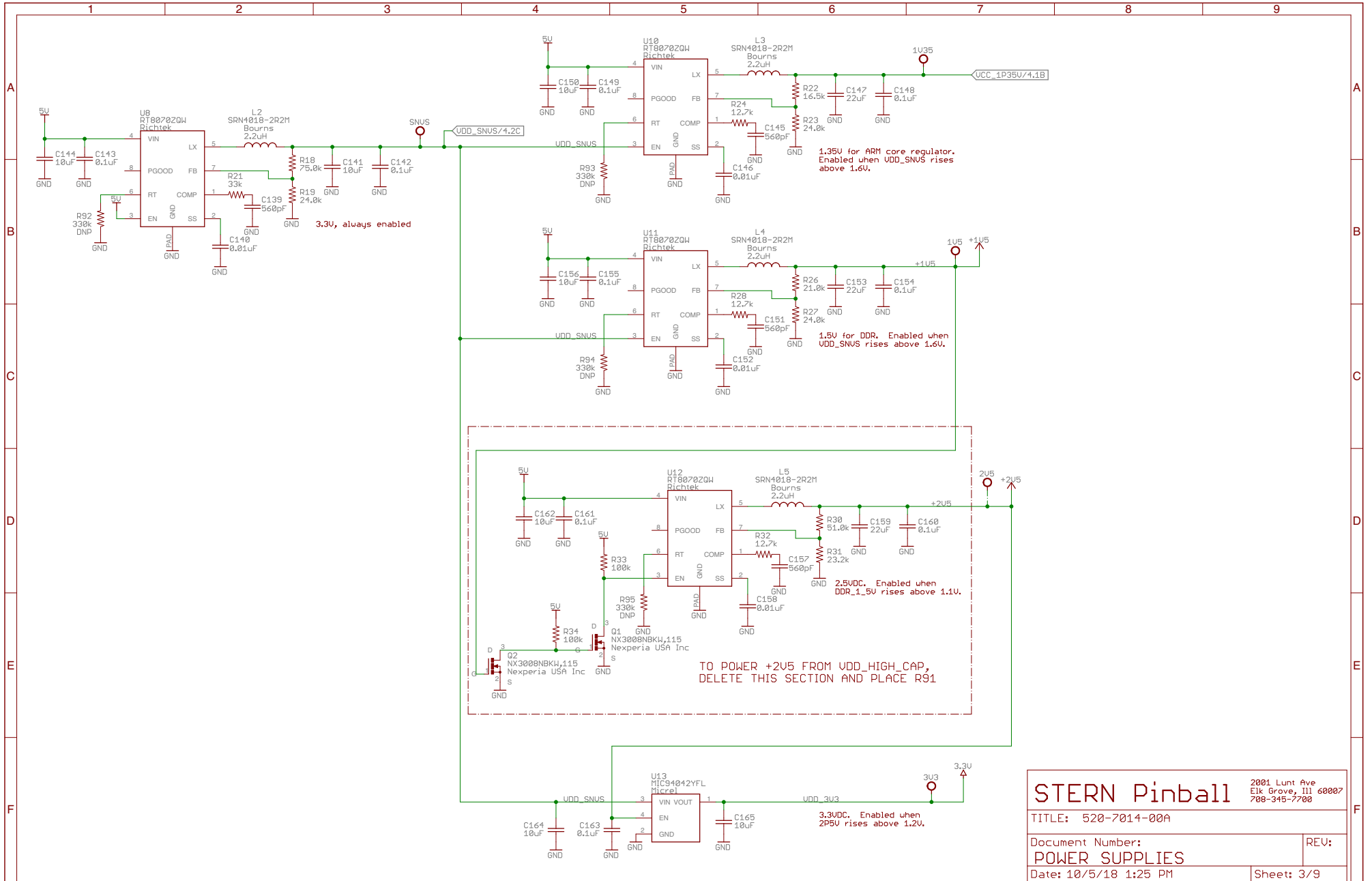

STERN Pinball		2001 Lunt Ave Elk Grove, Ill 60007 708-345-7700
TITLE: 520-7014-00A		
Document Number:	REV:	
POWER SUPPLIES		
Date: 10/5/18 1:25 PM	Sheet: 3/9	

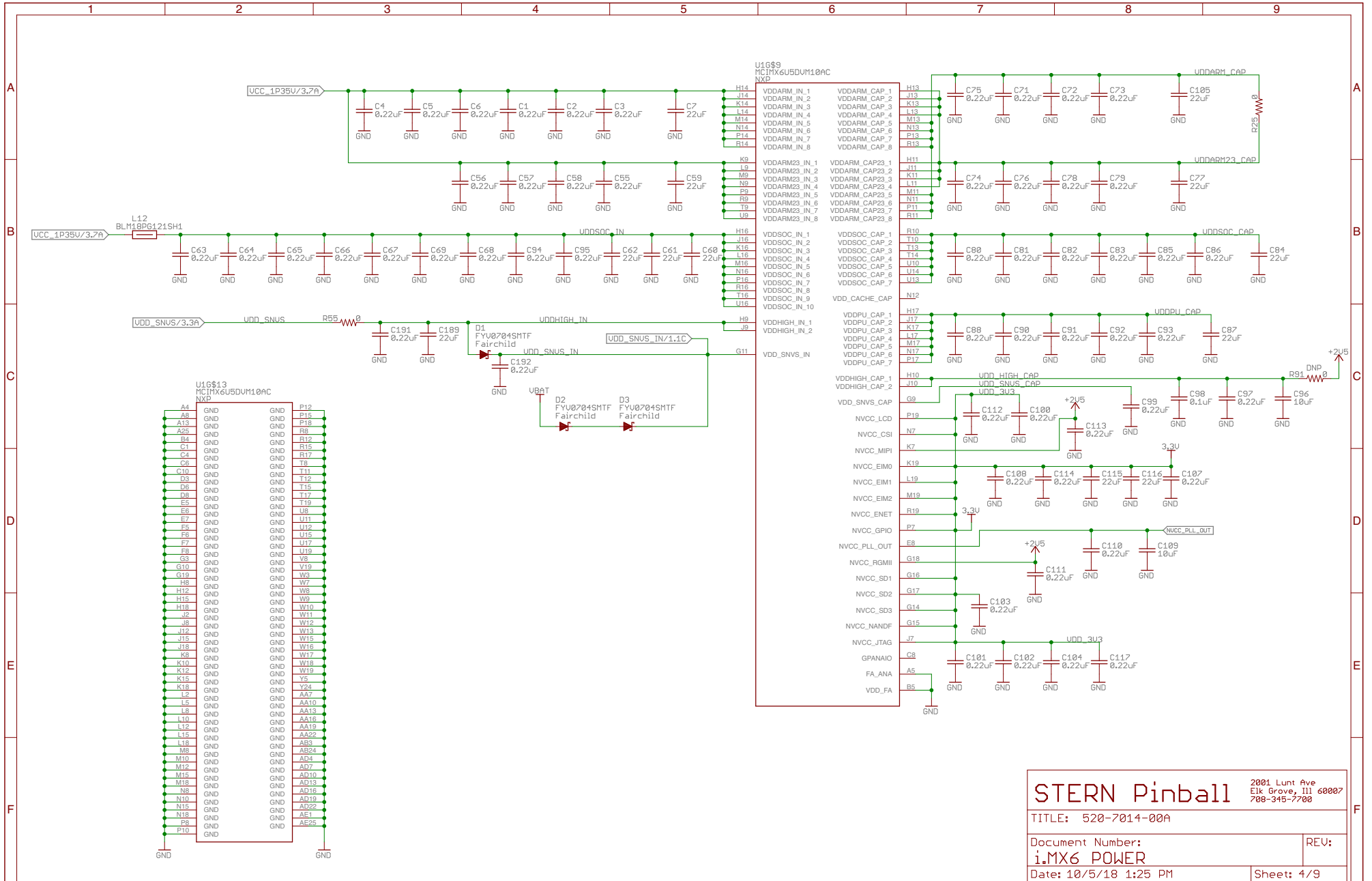

STERN Pinball		2001 Lunt Ave Elk Grove, Ill 60007 708-345-7700
TITLE: 520-7014-00A		
Document Number:	REV:	
i.MX6 POWER		
Date: 10/5/18 1:25 PM	Sheet: 4/9	

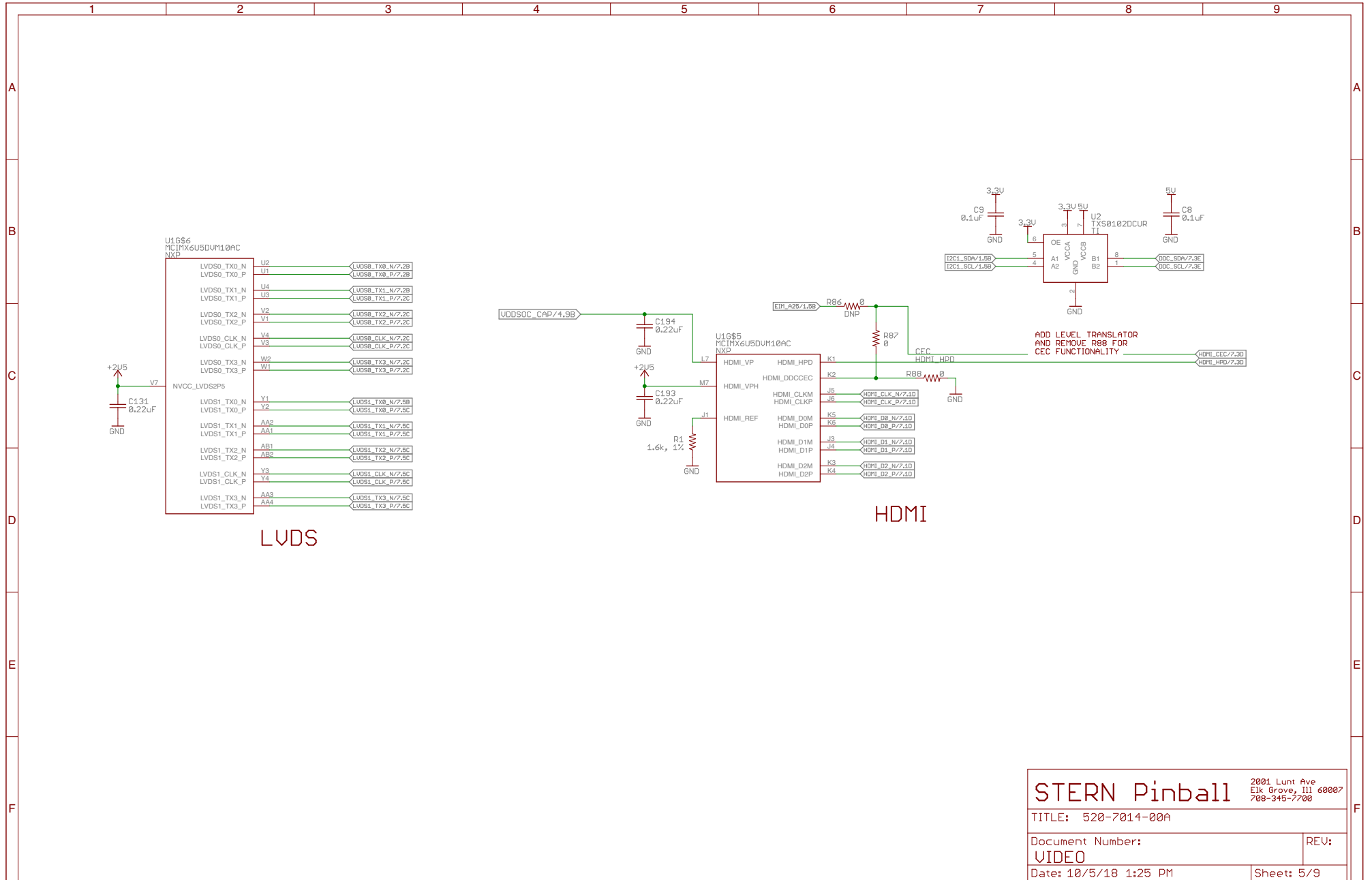

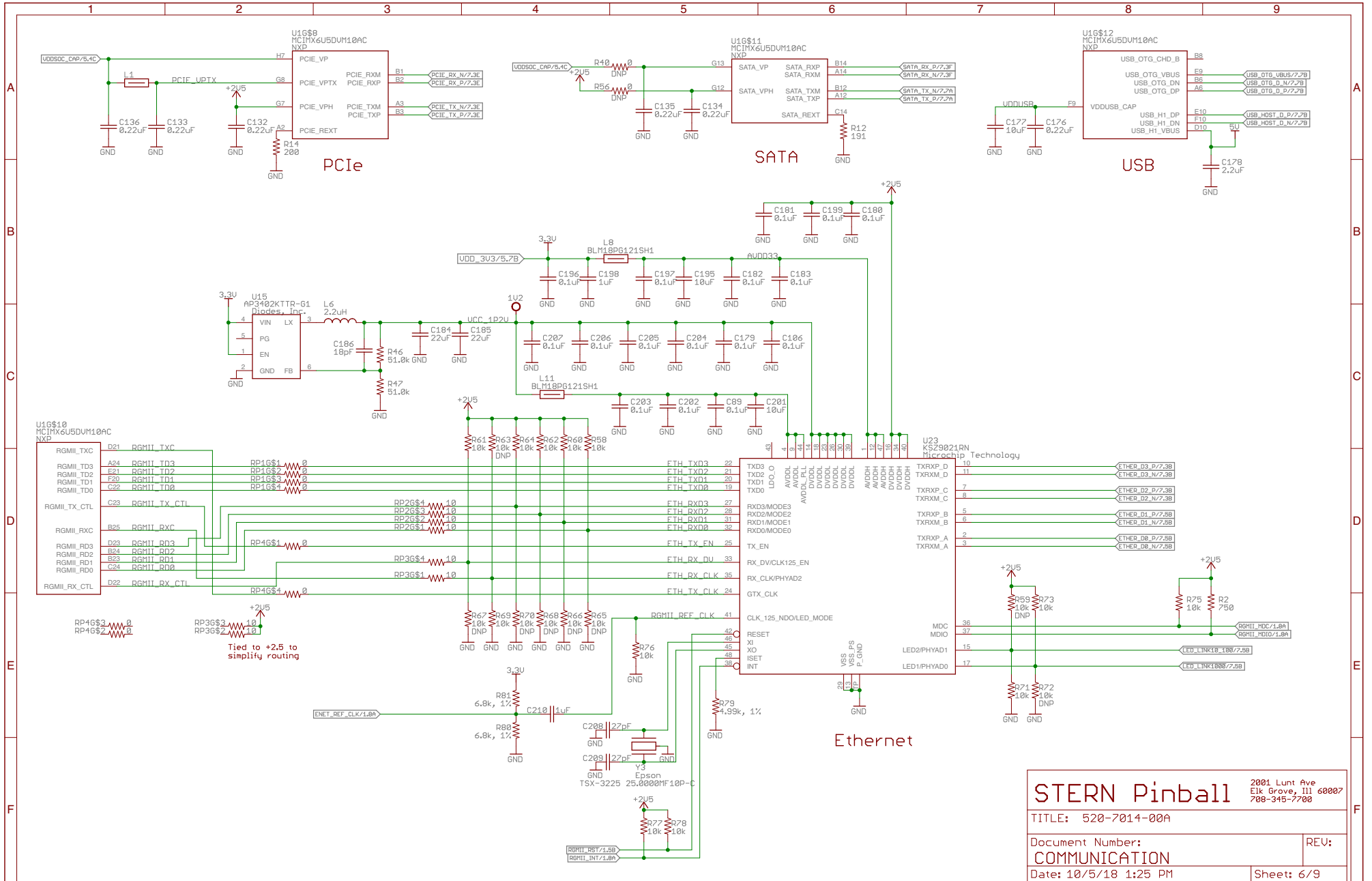

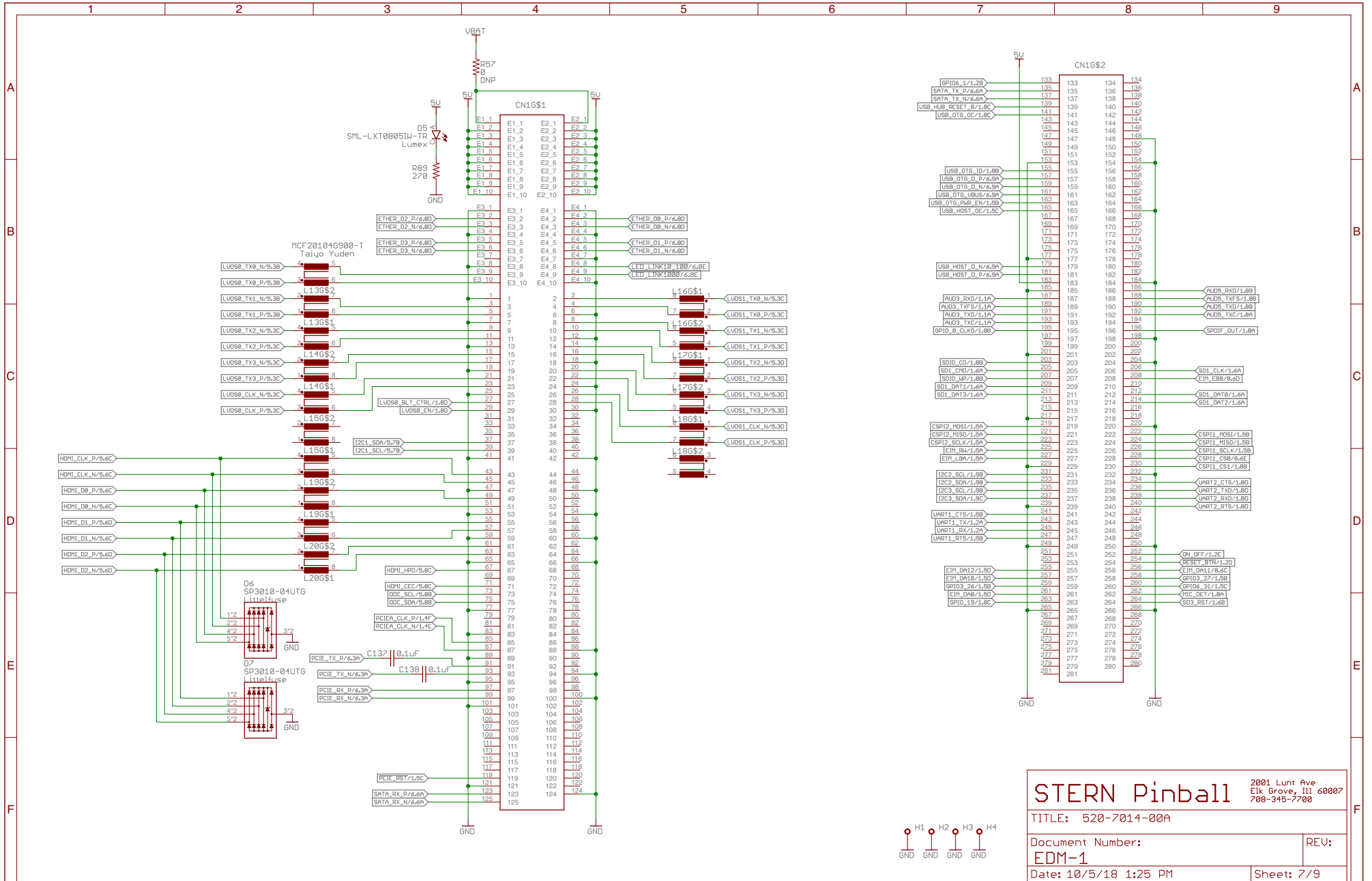

STERN Pinball		2001 Lunt Ave Elk Grove, Ill 60007 708-345-7700	
TITLE: 520-7014-00A			
Document Number:		REV:	
EDM-1			
Date: 10/5/18 1:25 PM		Sheet: 7/9	

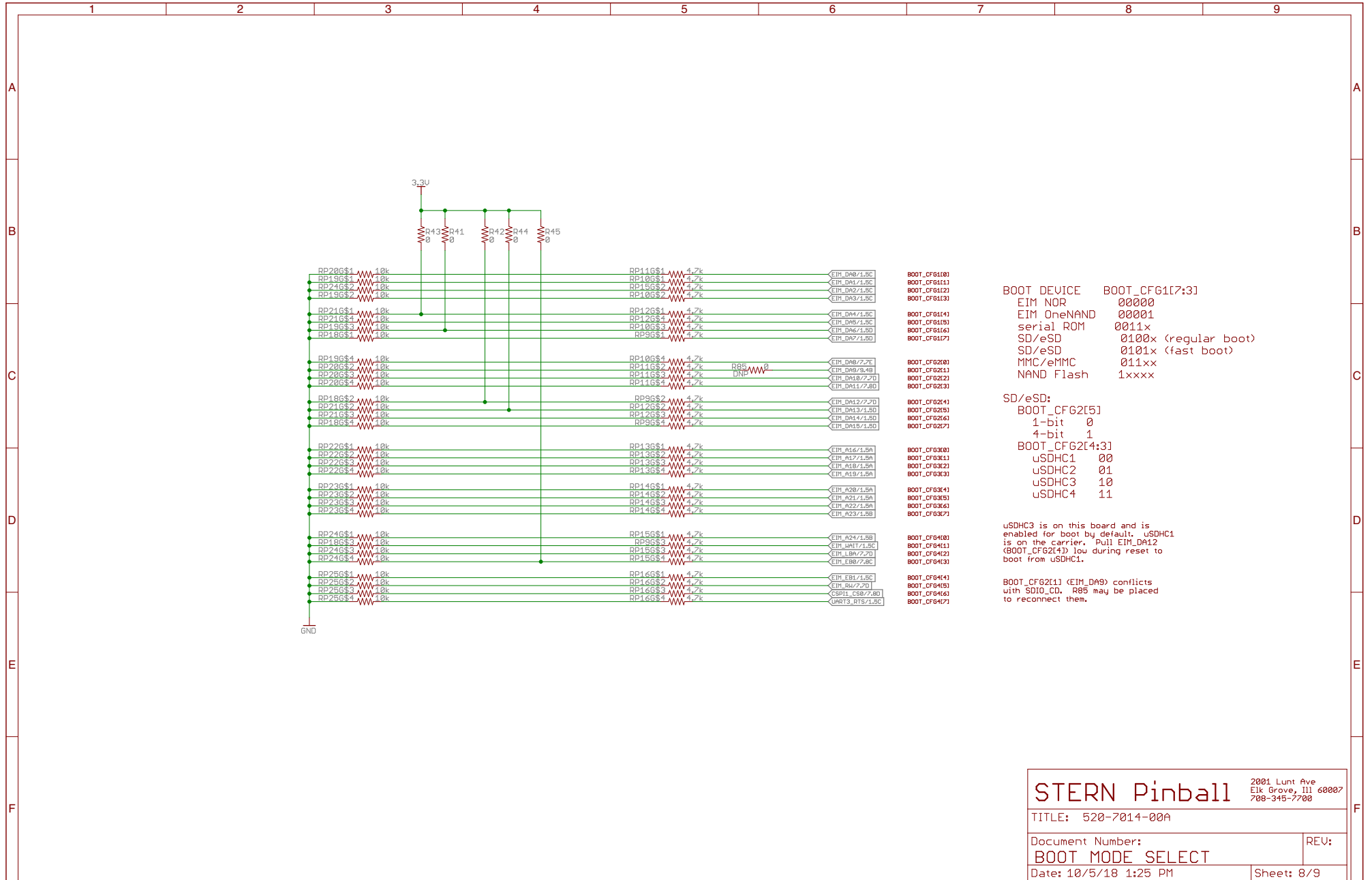

```

BOOT_DEVICE    BOOT_CFG1[7:3]
EIM_NOR        00000
EIM_OneNAND   00001
serial_ROM     0011x
SD/eSD         0100x (regular boot)
SD/eSD         0101x (fast boot)
MMC/eMMC      011xx
NAND_Flash    1xxxx

```

```

SD/eSD:
BOOT_CFG2[5]  1-bit 0
               4-bit 1
BOOT_CFG2[14:3]

```

```

BOOT_CFG3[0]
BOOT_CFG3[1]  uSDHC1 00
BOOT_CFG3[2]  uSDHC2 01
BOOT_CFG3[3]  uSDHC3 10
BOOT_CFG3[4]  uSDHC4 11

```

uSDHC3 is on this board and is enabled for boot by default. uSDHC1 is on the carrier. Pull EIM_DA12 (BOOT_CFG2[14]) low during reset to boot from uSDHC1.

BOOT_CFG4[4] (EIM_DA9) conflicts with SDIO_CD. R85 may be placed to reconnect them.

STERN Pinball		2001 Lunt Ave Elk Grove, Ill 60007 708-345-7700
TITLE: 520-7014-00A		
Document Number:	REV:	
BOOT MODE SELECT		
Date: 10/5/18 1:25 PM	Sheet: 8/9	

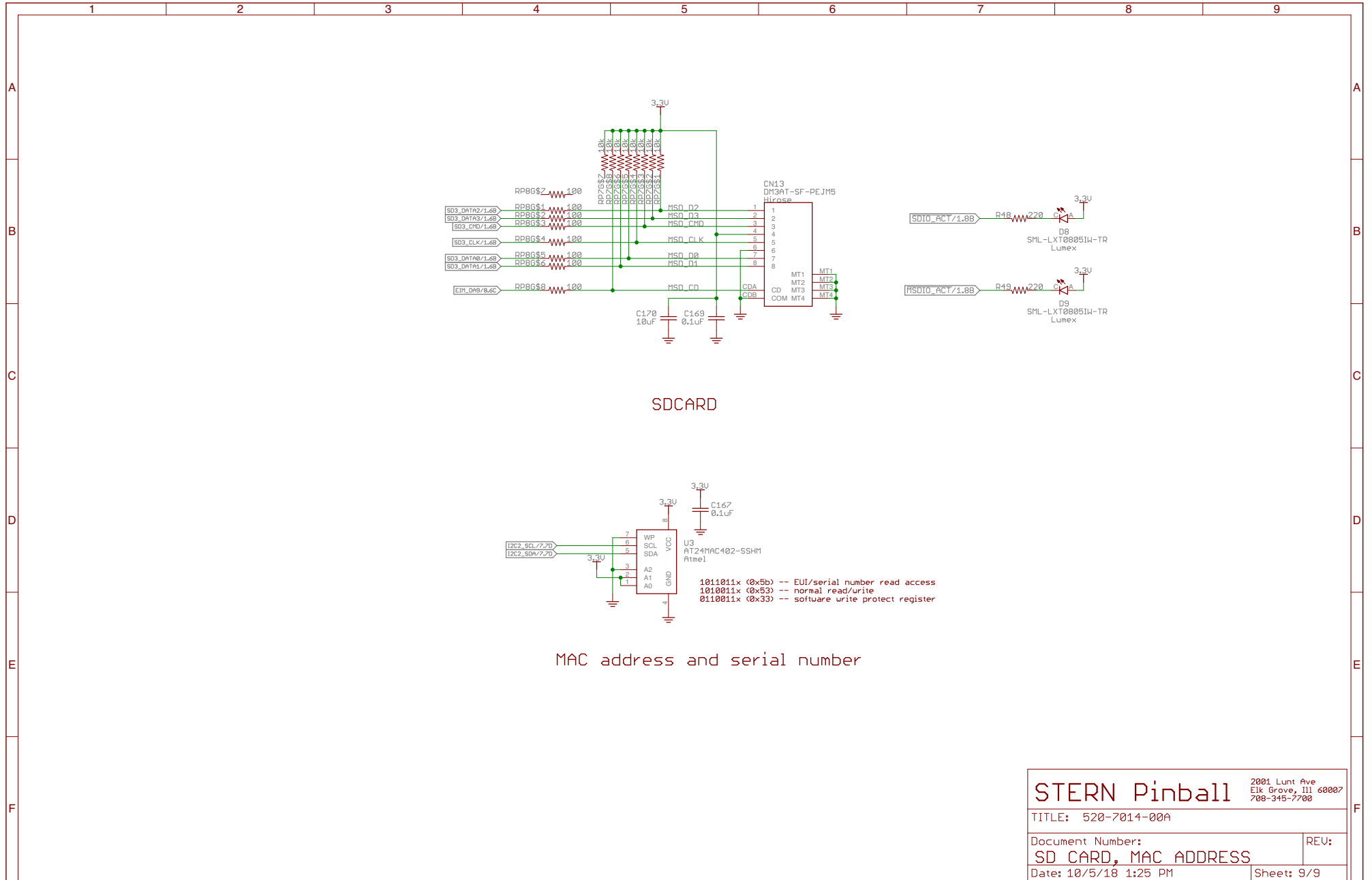

STERN Pinball 2001 Lunt Ave Elk Grove, Ill 60007 708-345-7700		
		TITLE: 520-7014-00A
Document Number:	REV:	
SD CARD, MAC ADDRESS		Date: 10/5/18 1:25 PM
Date: 10/5/18 1:25 PM		Sheet: 9/9