

|   |  |  |           |
|---|--|--|-----------|
| <b>STERN Pinball</b><br>2001 Lunt Ave<br>Elk Grove, Ill 60007<br>708-345-7700 |  | TITLE: 520-7031-01E                          |           |
|   |  | Document Number:<br>Communication Interfaces | REV:<br>E |
| Date: 2/25/19 2:49 PM   |  | Sheet: 2/9                                   |           |

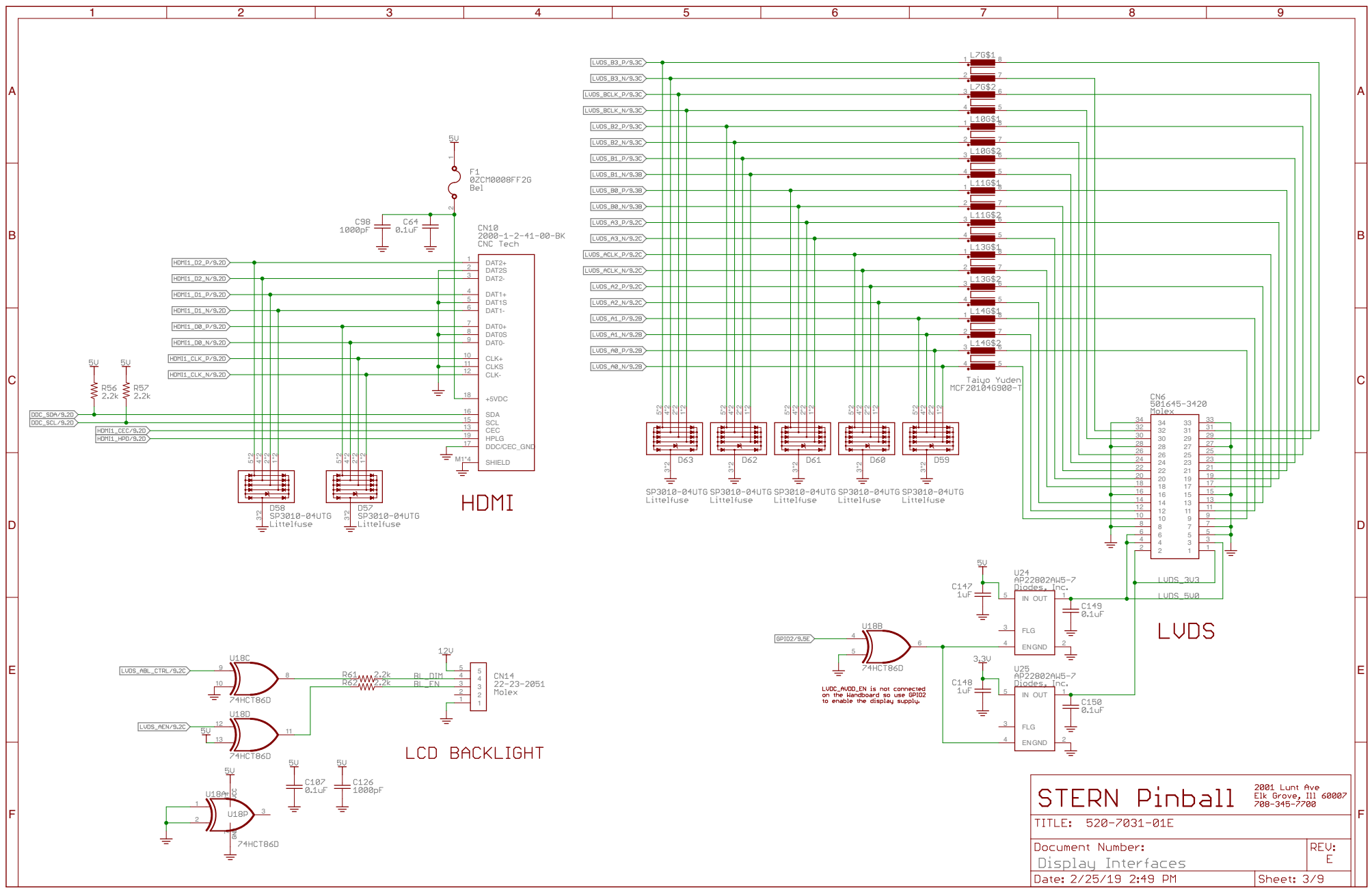

|                       |            |   |
|-----------------------|------------|---|
| <b>STERN Pinball</b>  |            | 2001 Lunt Ave<br>Elk Grove, Ill 60007<br>708-345-7700 |
| TITLE: 520-7031-01E   |            |   |
| Document Number:      | REV:<br>E  |   |
| Display Interfaces    |            |   |
| Date: 2/25/19 2:49 PM | Sheet: 3/9 |   |

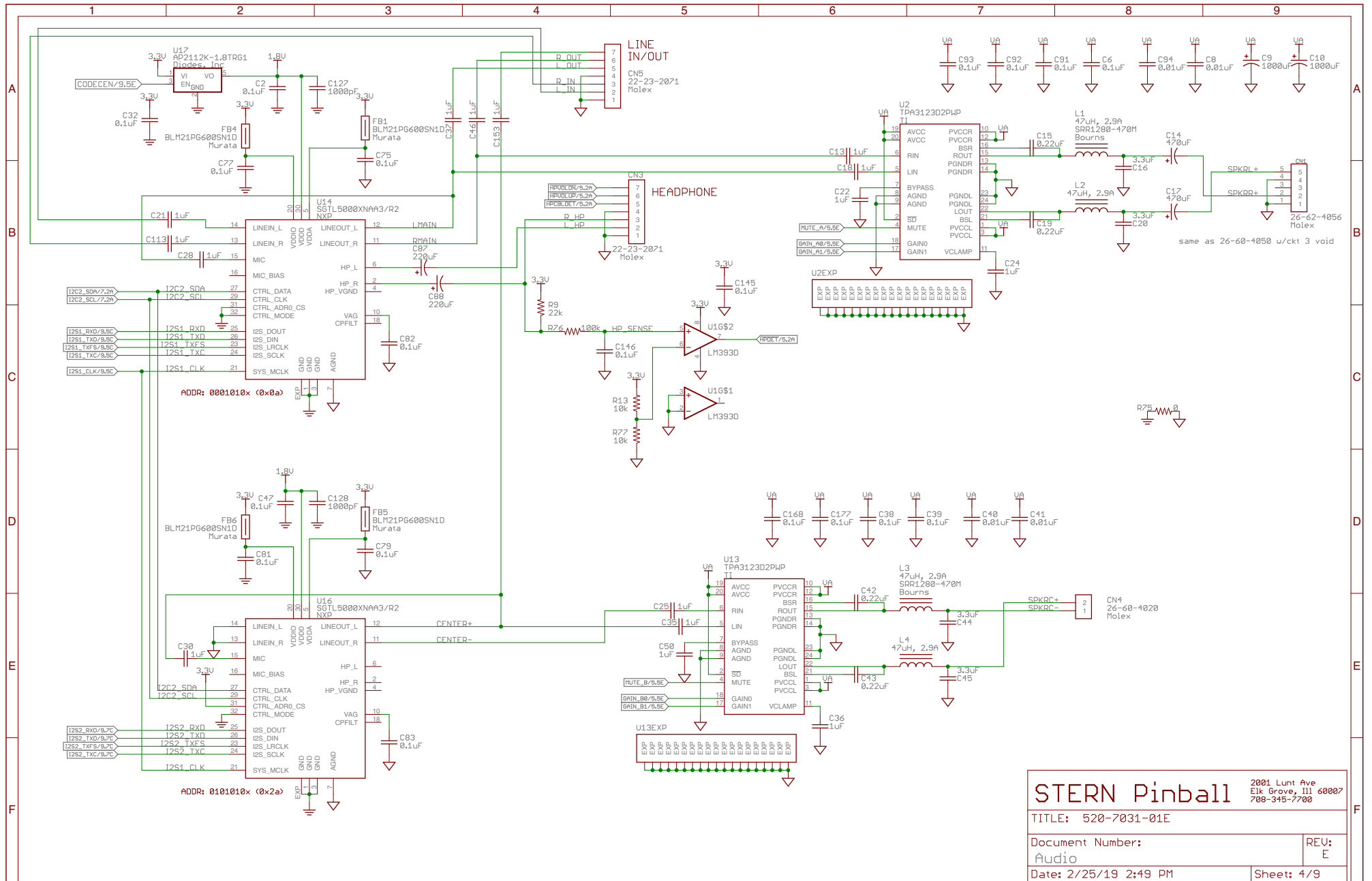

|                       |  |  |  |
|-----------------------|--|--|--|
| <b>STERN Pinball</b>  |  | 2001 Lunt Ave<br>Elk Grove, IL 60007<br>708-345-7700 |  |
| TITLE: 520-7031-01E   |  |  |  |
| Document Number:      |  | REV:<br>E  |  |
| Date: 2/25/19 2:49 PM |  | Sheet: 4/9   |  |

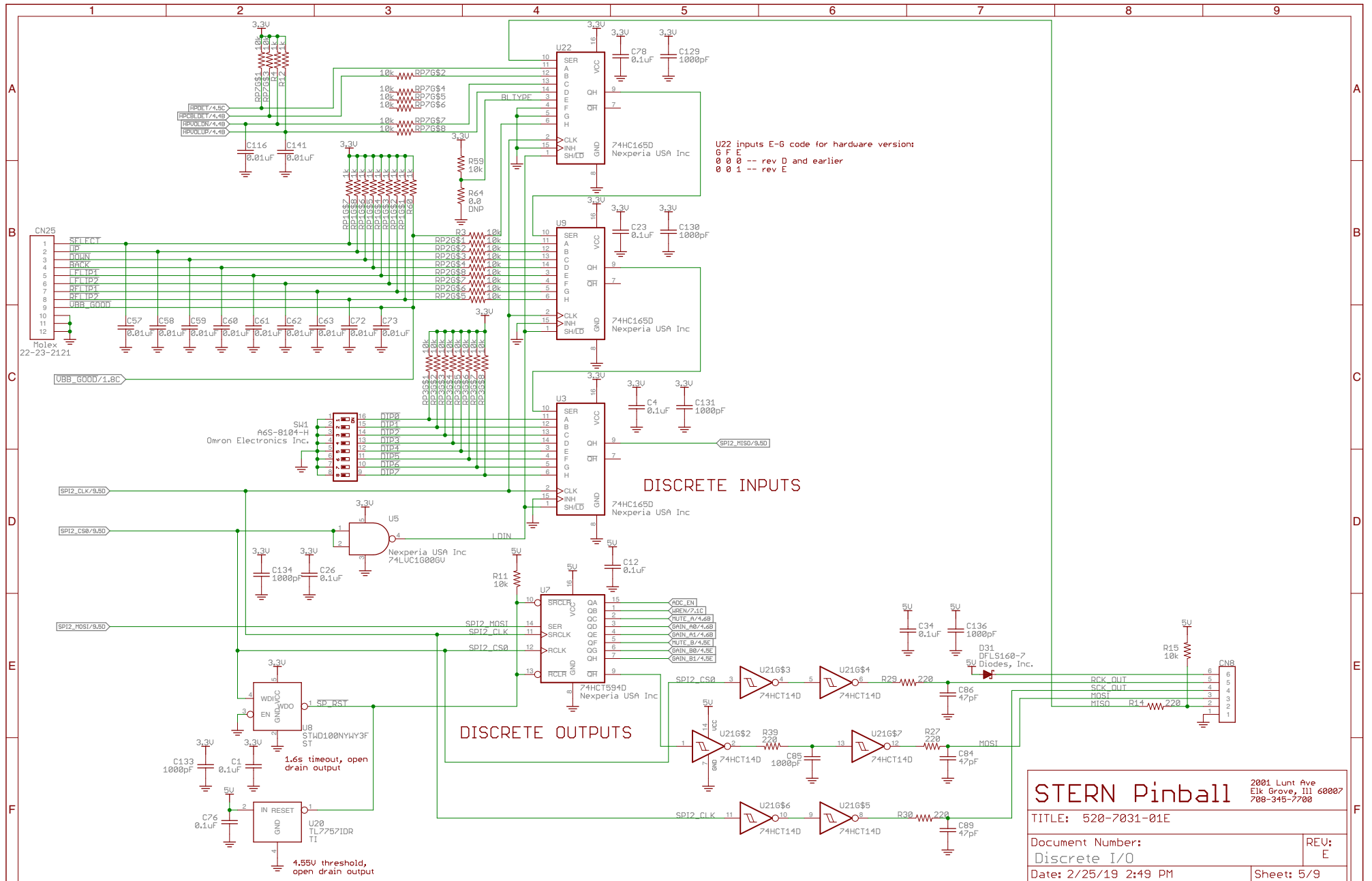

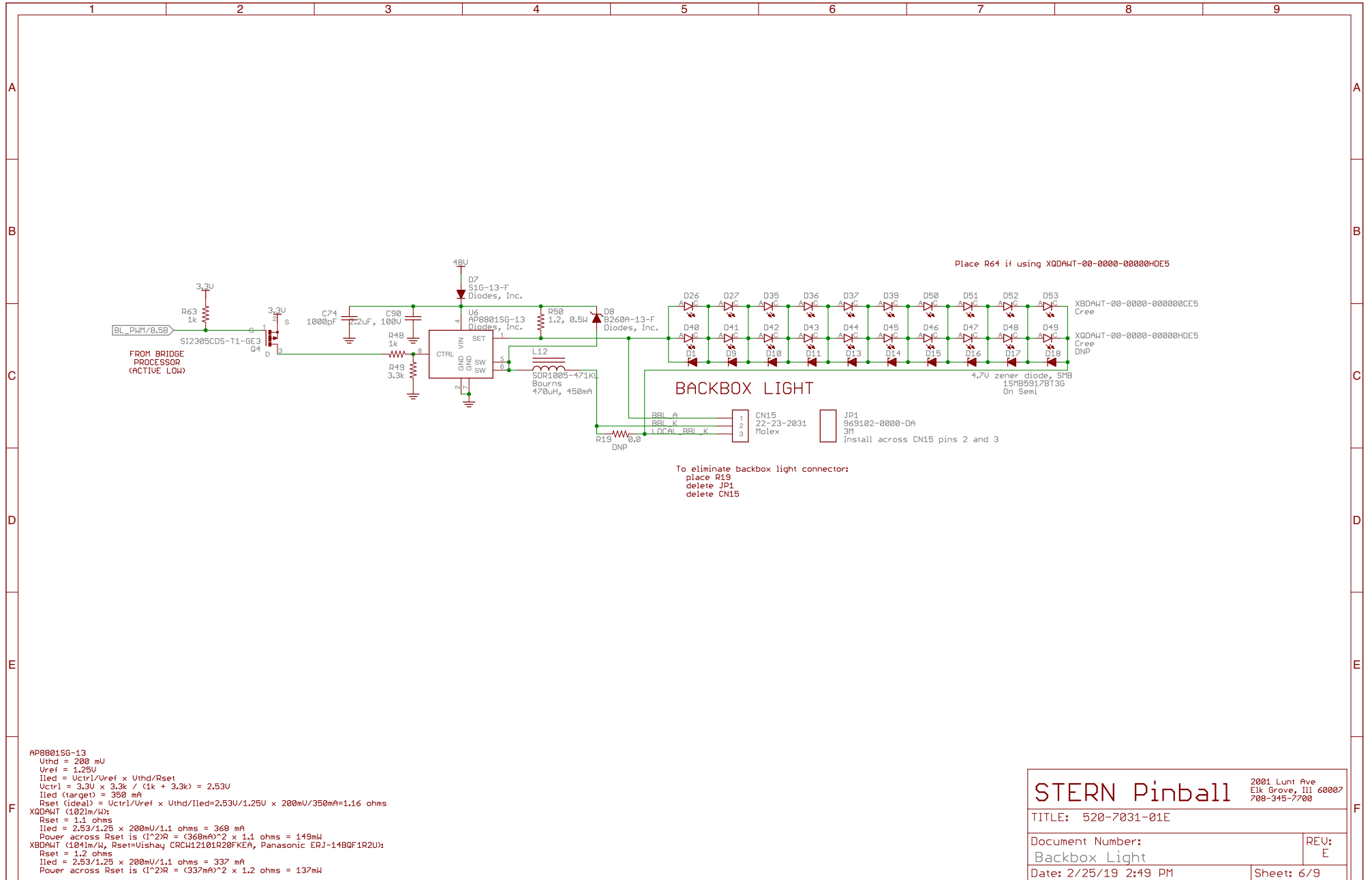

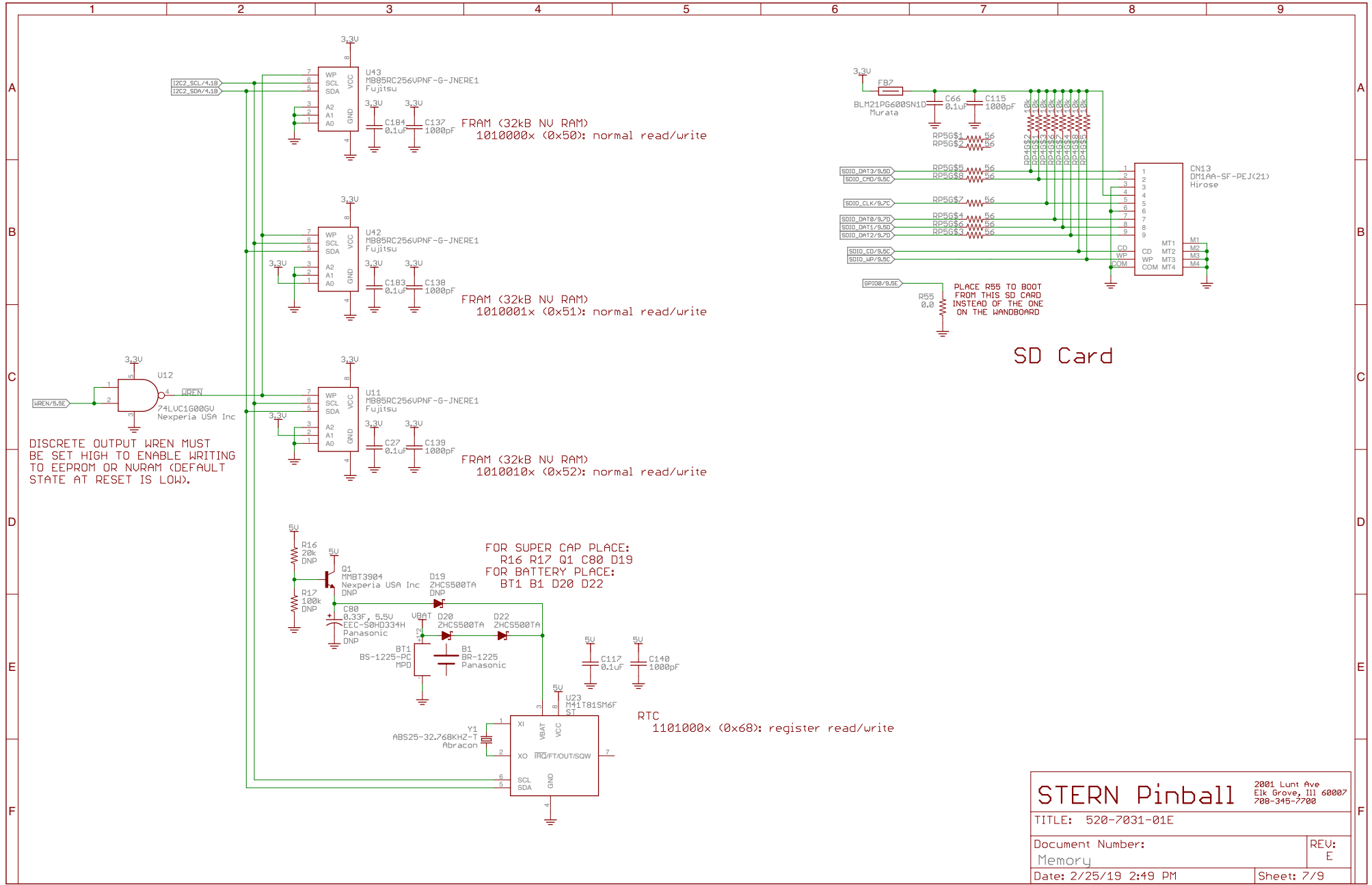

DISCRETE OUTPUT WREN MUST BE SET HIGH TO ENABLE WRITING TO EEPROM OR NURAM (DEFAULT STATE AT RESET IS LOW).

FRAM (32kb NU RAM)  
101000x (0x50): normal read/write

FRAM (32kb NU RAM)  
101001x (0x51): normal read/write

FRAM (32kb NU RAM)  
1011010x (0x52): normal read/write

FOR SUPER CAP PLACE:  
R16 R17 Q1 C80 D19  
FOR BATTERY PLACE:  
BT1 B1 D20 D22

RTC  
110100x (0x68): register read/write

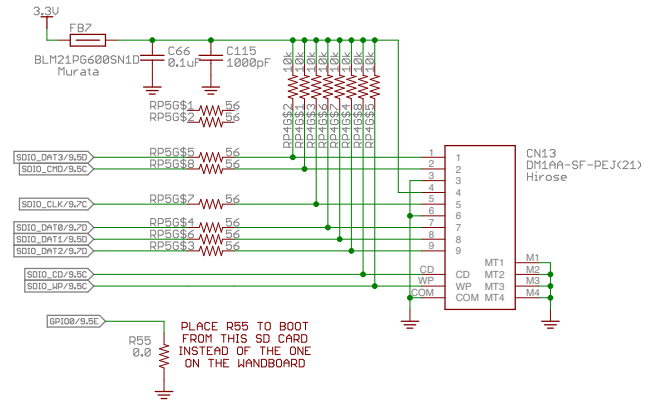

SD Card

|                       |  |   |            |
|-----------------------|--|---|------------|
| <b>STERN Pinball</b>  |  | 2001 Lunt Ave<br>Elk Grove, Ill 60007<br>708-345-7700 |            |
| TITLE: 520-7031-01E   |  |   |            |
| Document Number:      |  |   | REV:<br>E  |
| Date: 2/25/19 2:49 PM |  |   | Sheet: 7/9 |

