

# JAWS

## SERVICE AND OPERATION MANUAL



### WARNING

**IMPORTANT HEALTH WARNING: PHOTSENSITIVE SEIZURES** - A very small percentage of people may experience a seizure when exposed to certain visual images, including flashing lights or patterns. Even people with no history of seizures of epilepsy may have an undiagnosed condition that can cause "photosensitive epileptic seizures" due to certain visual images, flashing lights or patterns. Symptoms can include lightheadedness, altered vision, eye or face twitching, jerking or shaking of arms or legs, disorientation, confusion, momentary loss of awareness, and loss of consciousness or convulsions that can lead to injury from falling down or striking nearby objects.

IMMEDIATELY STOP PLAYING AND CONSULT A DOCTOR IF YOU EXPERIENCE ANY OF THESE SYMPTOMS.

### ATTENTION! IMPORTANT WARRANTY INFORMATION

The electronics system, node network architecture, mechanical devices and associated software control systems in this pinball machine are designed to work with genuine Stern Pinball accessories and devices.

Installation of non-authorized accessories, lamps, LED's, motors or other devices or modification of electro-mechanical devices may damage the system and will void your warranty.

Stern Pinball machines are assembled in Elk Grove Village, Illinois, USA. Stern Pinball has inspected each game element to ensure it meets our quality standards.

Each pinball machine has unique characteristics that make it a one-of-a-kind American made product. Each will have variations in appearance resulting from differences in the machine's particular wood parts, individual printed art and mechanical assemblies. No playfield is perfectly flat and varies depending on the season. Game play will result in playfield dimpling as the harder steel ball contacts the wood and coating; over time multiple dimples will blend to make them less noticeable. Normal plastic insert crazing (tiny stress cracks) and ghosting (small cloudy areas around insert edges) are often seen in pinball machines, due to a combination of plastic mold stress, pushing of inserts into purposely undersized holes, and heating and breaking of inserts' plastic "skin" when the playfield is sanded.

© Universal City Studios LLC. All Rights Reserved.

Games configured for North America operate on 60 cycle electricity only. These games will not operate in countries with 50 cycle electricity (Europe, UK, Australia).



MANUAL #780-50V6-00  
JAWS LE #500-55V6-01  
JAWS PREMIUM #500-55V7-01

1-800-KICKERS - [parts.service@sternpinball.com](mailto:parts.service@sternpinball.com)  
[www.sternpinball.com](http://www.sternpinball.com) - [facebook.com/sternpinball](https://facebook.com/sternpinball)

# TABLE OF CONTENTS

<b>1. Setup and Moving.....</b>	<b>3</b>	5.15 Pop Bumper Assembly.....	49
1.1 First-Time Setup Instructions.....	3	5.16 Bottom Arch Assembly.....	50
1.2 Adjustments Menu.....	6	5.17 Ball Deflector Assembly.....	50
1.3 Transporting the Game.....	7	5.18 3-Bank Drop Target Assembly.....	51
1.4 Maintenance.....	8	5.19 Fishing Reel Spinner Assembly.....	52
1.5 Maintenance Kits.....	8	5.20 Lower Horizontal Spinner Assembly.....	52
1.6 Common Parts.....	8	5.21 Shark Fin Assembly.....	53
<b>2. SPIKE System and Node Guide.....</b>	<b>9</b>	5.22 Shark Fin Arm Assembly.....	53
2.1 SPIKE System Overview.....	9	5.23 Shark Fin Plate Assembly.....	54
2.2 Node Bus Cabling.....	9	5.24 Shark Fin Main Bracket Assembly.....	54
2.3 System Power.....	9	5.25 Shark Fin Target Assembly.....	54
2.4 SPIKE Node Addresses.....	9	5.26 Shark Fin Motor Assembly.....	55
2.5 SPIKE Node Programming.....	10	5.27 Chum Bucket Full Assembly.....	55
2.6 SPIKE System Terminology.....	10	5.28 Chum Bucket Target Assembly.....	56
2.7 Common SPIKE Node Boards.....	10	5.29 Chum Bucket Assembly.....	56
<b>3. Light, Switch, and Driver Reference.....</b>	<b>11</b>	5.30 Helicopter Sensor Assembly.....	57
3.1 SPIKE Node Boards.....	11	5.31 Harpoon Gate Assembly.....	57
3.2 Driver Reference.....	12	5.32 Reflective Opto Spinner Assembly.....	57
3.3 Switch Reference.....	14	5.33 Inlane Gate Assembly.....	57
3.4 Light Reference.....	18	5.34 Shark Assembly.....	58
3.5 Motor Reference.....	25	5.35 Shark Lift Platform Assembly.....	58
<b>4. Electronic Pinouts and Schematics.....</b>	<b>26</b>	5.36 Shark Playfield Protector Assembly.....	59
4.1 SPIKE-2 CPU Node 0.....	26	5.37 Quint's Shack Assembly.....	59
4.2 Cabinet Node 1.....	30	5.38 Boat Assembly.....	60
4.3 Lower Playfield 48V Driver Pinout Node 8.....	31	5.39 Boat Decals.....	61
4.4 Upper Playfield 48V Driver Pinout Node 9.....	32	5.40 Boat Hinge Assembly.....	61
4.5 Center LED Board 8b.....	33	5.41 Plastic 03 Assembly.....	62
4.6 Lower Mid Right LED Board 8b1.....	34	5.42 Plastic 05 Assembly.....	62
4.7 3-LED Board 8c1.....	34	5.43 Plastic 13 Assembly.....	62
4.8 3-LED Board 8c2.....	34	5.44 Plastic 17 Assembly.....	63
4.9 Billboard 4-LED Board 8c3.....	34	5.45 Plastic 18 Assembly.....	63
4.10 Left LED Board 8c.....	35	5.46 Plastic 92 Assembly.....	63
4.11 1-RGB 5-WHT LED Board 9a, 9b, 9c, 9d, 9e.....	36	5.47 Plastic 94 Assembly.....	63
4.12 Shark Fin LED Board 9f.....	36	5.48 Plastic 96 Assembly.....	64
4.13 Serial Motor Driver Board 9g.....	37	5.49 Plastic 97 Assembly.....	64
4.14 Serial 16-LED Board 9h.....	37	5.50 Plastic 98 Assembly.....	64
4.15 Trough Serial Opto Receiver 8a.....	38	5.51 Ball Guide 01 Assembly.....	65
4.16 Trough Serial Opto Transmitter.....	38	5.52 Ball Guide 02 Assembly.....	65
4.17 Main Power Supply.....	38	5.53 Ball Guide 03 Assembly.....	65
4.18 Power Distribution Board.....	39	5.54 Ball Guide 56 Assembly.....	65
4.19 Power Plug Wiring.....	39	5.55 Left Side Rail Assembly.....	66
<b>5. Parts Reference.....</b>	<b>40</b>	5.56 Dump Ramp Assembly.....	66
5.1 Playfield Rubber Parts.....	40	5.57 Right Ramp Assembly.....	66
5.2 Rubber Size Chart.....	40	5.58 Upper Ramp Assembly.....	67
5.3 Playfield Assemblies, Top.....	41	5.59 Left Ramp Assembly.....	67
5.4 Playfield Assemblies, Bottom.....	42	5.60 Switch Gate Assembly.....	67
5.5 Backbox Parts.....	43	5.61 Center Ramp Rollunder Switch Gate Assembly.....	67
5.6 Speaker Panel Parts.....	44	5.62 Upper Playfield Assembly.....	68
5.7 Speaker Panel Parts - LE.....	44	5.63 Ship Wheel Spinner Assembly.....	69
5.8 Cabinet Parts.....	45	5.64 Back Panel Assembly.....	69
5.9 Ball Shooter Assembly.....	46	<b>6. Specifications.....</b>	<b>70</b>
5.10 Auto Launch Assembly.....	46	6.1 Game Dimensions.....	70
5.11 Ball Trough Assembly.....	47	6.2 Warranty.....	71
5.12 Slingshot Assembly.....	47	6.3 Warnings, Compliance, and Legal Notices.....	71
5.13 Flipper Assembly, Left.....	48	6.4 Stern Pinball End User License Agreement.....	72
5.14 Flipper Assembly, Right.....	48		



# 1. SETUP AND MOVING

## 1.1 FIRST-TIME SETUP INSTRUCTIONS

Your brand new Stern Pinball Machine is carefully packed for safety and security. For your safety, exercise caution and use the correct tools and sufficient help when setting up your new game.

### TOOLS REQUIRED

- 5/8" Socket Wrench
- Utility Knife
- Snips
- An Assistant

**CAUTION: AT LEAST TWO (2) PEOPLE ARE REQUIRED TO MOVE AND MANEUVER THE GAME. USE PROPER MOVING EQUIPMENT AND EXTREME CARE WHILE HANDLING. STERN PINBALL MACHINES WEIGH OVER 250LBS BOXED.**

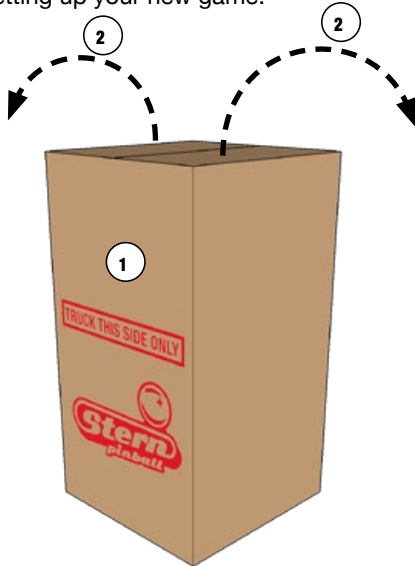

1. Locate the side labeled "TRUCK THIS SIDE ONLY". The bottom of the game faces this side.
2. Open the top box flaps by pulling hard in an upward motion on each flap. If the flaps are taped, cut the tape first, taking care to avoid the box staples.



3. Remove the four (4) foam pieces and two (2) narrow box tubes which contain the four (4) identical legs with levelers.
4. DO NOT CUT STRAPPING YET. Keep backbox secured in the down position.
5. With the utility knife, carefully cut down the left and right corners of the box.

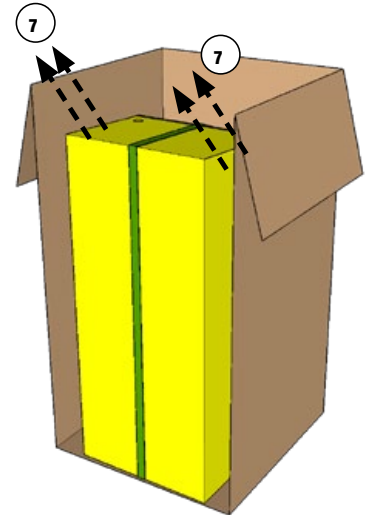

6. Let the face fall forward and remove the entire side by carefully cutting the bottom.
7. With the game still in its folded position, use a 5/8" wrench to loosen and remove the 2 leg bolts on each side of the front cabinet. Ensure the leg levelers are screwed all the way into the legs.

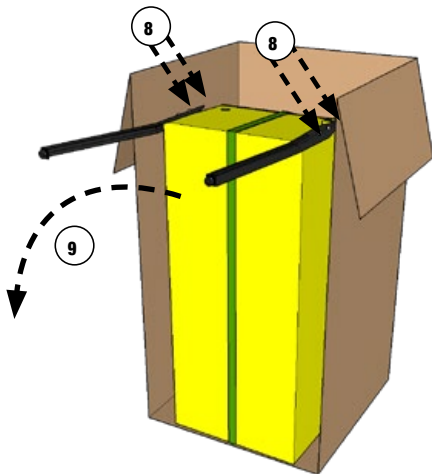

8. Install front legs using the bolts removed from the cabinet. Secure tightly.
9. Have someone help you carefully set the game down on the front legs.

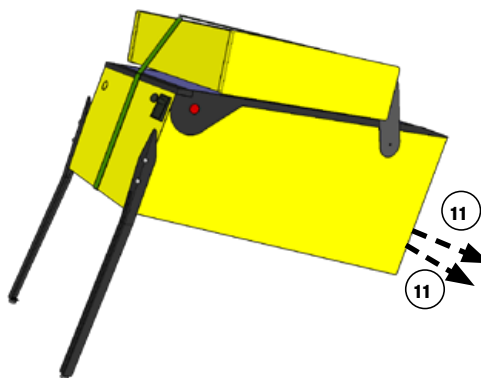

10. Set aside the open box.
11. With a 5/8" socket wrench, loosen and remove the 2 leg bolts on each side of the rear cabinet, 4 total.

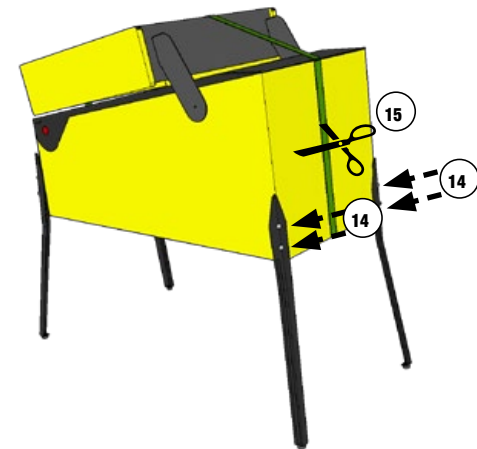

12. Using supports or two people, prop the rear of the cabinet up.
13. Ensure the rear leg levelers are screwed all the way into the legs.
14. Install rear legs using the 4 bolts removed from step 11.



# FIRST-TIME SETUP CONTINUED



15. Cut nylon strapping and remove protective strap corner guards.
16. Locate the factory keys, either on the shooter rod or taped to the playfield glass.
17. Using snips, cut the tie-wrap securing the keys if required. One set of keys is for the front coin door, the other set of keys is for accessing components in the backbox.

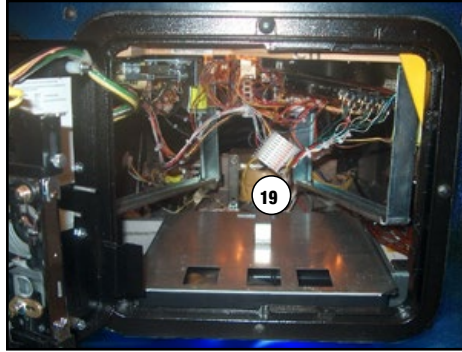

18. Open the front coin door.
19. Reach into the game and remove the retaining clip at the rear of the cash box.
20. Remove the cash box lid by sliding it toward you.

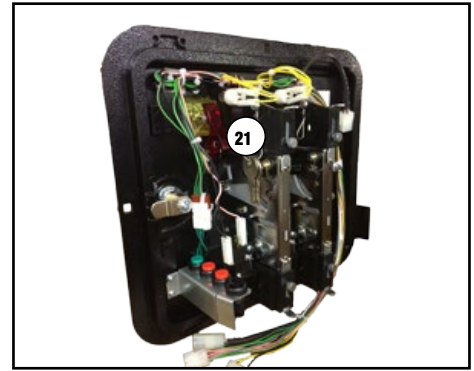

21. Store the backbox keys, if desired, on the metal hook located in the coin door.
22. Locate and remove the pinballs, plumb bob, and backbox bolts from the cash box.
23. Replace the cash box lid and retaining clip for future use.

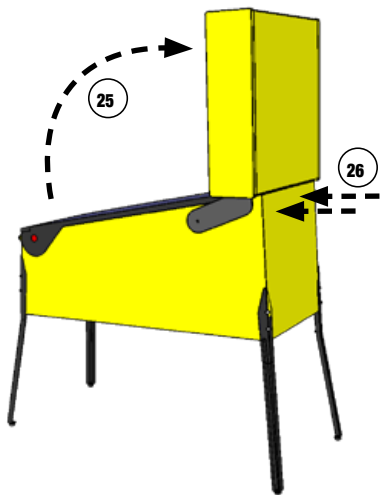

24. Locate the two (2) backbox bolts in the cash box.
25. Carefully raise backbox to upright position while ensuring that cables are not pinched.
26. Use the  $\frac{5}{8}$ " wrench to install the two (2) backbox bolts to secure the backbox as indicated on the back of the cabinet.

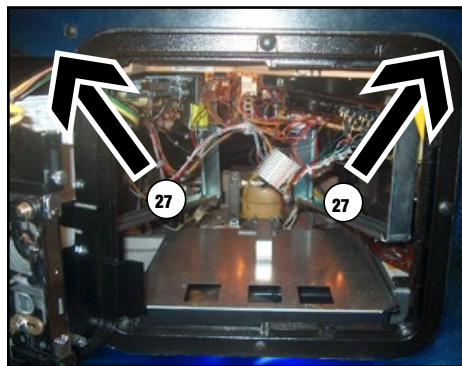

27. Reach inside the cabinet and lift the two latches located on either side of the coin door.
28. Remove the front top molding.



29. Remove the playfield glass by sliding it toward you and carefully place it in a safe location. Remove all playfield shipping tie downs, shipping blocks, and packing foam, and follow any game-specific unpacking instructions included in the playfield, if present.

**CAUTION: PLAYFIELD GLASS IS MADE FROM HIGH-STRENGTH TEMPERED GLASS. TEMPERED GLASS IS SENSITIVE TO EXTREME TEMPERATURE SHIFTS AND CORNER NICKS, WHICH CAN CAUSE THE GLASS TO FAIL CATASTROPHICALLY. TAKE CARE TO STORE THE GLASS ON A SOFT, ROOM-TEMPERATURE SURFACE AND PREVENT THE CORNERS FROM BEING DAMAGED.**

## FIRST-TIME SETUP CONTINUED

30. If pinballs were already installed into the lower ball trough, remove them before lifting the playfield.
31. Grasp the lower arch between the flippers, and firmly but gently pull directly up to raise the playfield 8 to 12 inches.
32. While holding the playfield up, pull the playfield toward you until the two playfield supports are over the front edge of the cabinet.
33. Rest the playfield on the front edge of the cabinet.
34. Raise the playfield and rest it against the backbox.
35. Visually inspect all cabinet cables and connector terminations; ensure no wires or cables are pinched and that cable harnesses are not pulled tight.
36. Locate the plumb bob in the parts bag in the cash box.
37. Slide plumb bob onto the hanger wire. Note: the vertical position of the plumb bob affects tilt sensitivity - higher makes the game more sensitive to tilting.
38. Tighten the thumb screw finger-tight.
39. Install the correct number of pinballs. Refer to the decal on the lock down assembly for the correct number of pinballs.

## LOCATING, LEVELING, AND FINAL SETUP

1. Select a location that is indoors, out of direct sunlight, and climate controlled. Excessive moisture/humidity can cause long-term damage to your game.
2. Adjust the front or rear levelers as necessary to position the playfield level bubble, located on the front right of the playfield next to the shooter lane, to float between the two (2) black lines. This will place the playfield at the recommended 6.5° pitch. Playfield angles greater than 6.5° can be achieved by turning out the rear leg leveler(s) for increased difficulty and faster gameplay.
3. Use a pinball to roll down the center of the playfield for side-to-side leveling, or use an external bubble level, digital level, or smartphone level app.
4. Plug into a grounded outlet and check for proper operation through DIAGNOSTICS.
5. Check the coin door: With the door closed, insert coins to verify proper operation.
6. Play game: Check for satisfactory operation and adjust game volume (push the Red Buttons inside the Coin Door).
7. If desired, perform any game diagnostics, game adjustments, and pricing settings at this time.



## SPIKE PINBALL SOFTWARE UPDATE INSTRUCTIONS

1. Obtain game software update file (filename ends in “.spk”) from [www.sternpinball.com](http://www.sternpinball.com) or from authorized Stern distributor.
2. Place game software update file (“.spk”) in root directory of a blank FAT32-formatted USB flash drive
3. Use backbox power switch to turn off game
4. Plug in USB flash drive to CPU board USB connector (CN20 or CN21). Refer to [www.sternpinball.com](http://www.sternpinball.com)
5. Turn on game
6. The game will automatically begin software update
7. Select the correct .spk update file from list.
8. Press Enter on the service switches to start update
9. When the display indicates “Update Complete”, turn off game
10. Remove USB flash drive from CPU board
11. Turn game on to complete the update and play pinball!
12. Detailed instructions and troubleshooting tips are available in the game manual, [www.sternpinball.com](http://www.sternpinball.com) and authorized Stern distributors.

### POWER SWITCH

The game’s power switch is located on the right-hand side underneath the backbox.

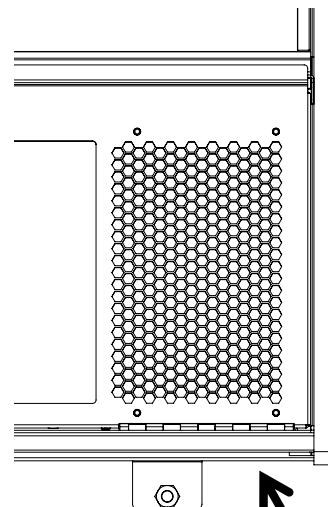

ON/OFF Switch

## 1.2 ADJUSTMENTS MENU

### STANDARD ADJUSTMENTS

Perform the below steps to review the adjustments.

Enter the Service Menu, then enter the Standard Adjustments Menu.

Press SELECT to access the Service Menu. Press BACK to exit or escape at any time.

Press [>]. Go to the ADJ icon. Press SELECT.

Go to the S.P.I. icon. Press SELECT.

STANDARD ADJUSTMENT #1 appears with the adjustment name flashing. While the adjustment name is flashing press [<] [>] to move between adjustments.

To change the adjustment setting press SELECT. While the adjustment setting is flashing, press [<] [>] repeatedly until the desired setting appears. Press the SELECT button to “install” the change. The adjustment comment (bottom line) will indicate if the factory default setting is selected or will display INSTALLED if the change is not a factory default setting.

ID	Adjustment Name	Default Setting
1	FREE PLAY	NO
2	GAME PRICING	USA 11
3	REPLAY TYPE	AUTO
4	REPLAY PERCENTAGE	10%
5	REPLAY AWARD	CREDIT
6	REPLAY LEVELS	1
7	AUTO REPLAY START	150,000,000
8	DYNAMIC REPLAY START	150,000,000
9	REPLAY LEVEL #1	150,000,000
10	REPLAY LEVEL #2	175,000,000
11	REPLAY LEVEL #3	225,000,000
12	REPLAY LEVEL #4	350,000,000
13	REPLAY BOOST	YES
14	SPECIAL LIMIT	1
15	SPECIAL PERCENTAGE	10%
16	SPECIAL AWARD	CREDIT
17	FREE GAME LIMIT	5
18	EXTRA BALL LIMIT	5
19	EXTRA BALL PERCENTAGE	25%
20	MATCH PERCENTAGE	9%
21	MATCH AWARD	CREDIT
22	BALLS PER GAME	3
23	MAX PLAYERS PER GAME	4
24	TILT WARNINGS	2
25	TILT DEBOUNCE	750
26	CREDIT LIMIT	30
27	REMOVE FRACTIONAL CREDITS	NEVER
28	ALLOW HIGH SCORES	YES
29	HIGH SCORE AWARD	CREDIT
30	GRAND CHAMPION AWARDS	1
31	HIGH SCORE #1 AWARDS	0
32	HIGH SCORE #2 AWARDS	0
33	HIGH SCORE #3 AWARDS	0
34	HIGH SCORE #4 AWARDS	0
35	GRAND CHAMPION SCORE	60,000,000
36	HIGH SCORE #1	50,000,000

37	HIGH SCORE #2	40,000,000
38	HIGH SCORE #3	30,000,000
39	HIGH SCORE #4	25,000,000
40	HSTD INITIALS	3 INITIALS
41	HSTD RESET COUNT	2000
42	LANGUAGE	ENGLISH
43	PLAYER LANGUAGE SELECT	YES
44	CUSTOM MESSAGE	ON
45	KNOCKER VOLUME	NORMAL
46	START GAME ON CREDIT	OFF
47	START BUTTON BEHAVIOR	ALL LOGGED IN
48	GAME RESTART	YES
49	GAME MODE ON START	STANDARD
50	INSIDER LOGIN TIMER	30
51	INSIDER PLAY AGAIN TIMER	20
52	USE INSIDER HOME TEAM	NEVER
53	ENABLE HOME TEAM IN COINPLAY	NO
54	HOME TEAM GUEST RETENTION	UNTIL POWER OFF
55	DISPLAY MESSAGE OF THE DAY	YES
56	START BUTTON ATTRACT MODE ILLUM.	BLINKING
57	ALLOW LEFT+START TO END GAME	ALWAYS
58	BALL SAVE TIME	0:12
59	TARGET GAME TIME	1:45
60	TIMED PLUNGER	OFF
61	FLIPPER BALL LAUNCH	OFF
62	COINDOOR BALL SAVER	NO
63	COMPETITION MODE	NO
64	Q24 OPTION	COIN METER
65	TICKET DISPENSER	NONE
66	PLAYER GAME MODE	YES
67	PLAYER COMPETITION MODE	YES
68	PLAYER CHALLENGE MODE	YES
69	PLAYER COOPERATION MODE	YES

70	DJ MIXER MODE	YES
71	DJ MIXER PLAYLIST MODE	ORDERED PLAYBACK
72	DJ MIXER PLAYLIST REPEAT	YES
73	LOCATION ID	0
74	GAME ID	0
75	TIME FORMAT	12-HOUR
76	PRICING FORMAT	STANDARD
77	CREDIT FORMAT	REDUCED FRACTION
78	COIN INPUT DELAY	30
79	COIN ACCEPTOR	MECHANICAL
80	LOST BALL RECOVERY	YES
81	COIN DOOR DISABLE TILT	NO
82	COIN DOOR OPEN NODEBUS POWER	YES
83	PLAY ATTRACT TUTORIAL VIDEOS	YES
84	FRONT VOLUME KNOB	HEADPHONES VOL. ONLY
85	MUTE IF HEADPHONES DETECTED	YES
86	MUTE KNOCKER IF HP DETECTED	NO
87	DISABLE Q24 KNOCK IF HP DETECTED	NO
88	GI LED BRIGHTNESS	100%
89	GI LED MAX BRIGHTNESS	255
90	INSERT LED BRIGHTNESS	100%
91	INSERT LED MAX BRIGHTNESS	255
92	FLASHER LED BRIGHTNESS	100%
93	FLASHER LED MAX BRIGHTNESS	255
94	CABINET LED BRIGHTNESS	100%
95	LCD DISPLAY BRIGHTNESS	7
96	ATTRACT MODE B.BOX BRIGHTNESS	100%
97	GAME PLAY B.BOX BRIGHTNESS	100%
98	SERVICE MENU B.BOX BRIGHTNESS	5%

### FEATURE ADJUSTMENTS

Each table has feature adjustments specific to the characteristics of that game. To access feature adjustments enter the Service Menu and then enter the Adjustments Menu.

Press SELECT to access the Service Menu. Press BACK to exit or escape at any time.

Press [>]. Go to the ADJ icon. Press SELECT.

Go to the game icon. Press SELECT.

FEATURE ADJUSTMENT #1 appears with the adjustment name flashing. With the adjustment name flashing press [<] [>] to move between adjustments. Feature adjustments are changed similarly to standard adjustments using the SELECT button to choose options and the [<] [>] buttons to cycle through available settings.

# 1.3 TRANSPORTING THE GAME

When transporting the game, such as in the back of a truck or with a hand truck, the game's backbox must be secured to prevent damage to the side rails.

## 1. SECURE THE BACKBOX

1. Ensure that the pinballs are removed from the playfield, and secure any free-moving mechanisms that may get damaged in transport

**TOOLS REQUIRED** i

- STRAP (500LB OR GREATER)
- AN ASSISTANT
- HAND TRUCK

**CAUTION**

**NEVER TRANSPORT THE GAME IN A MOVING VEHICLE WITH THE BACKBOX RAISED! TWO PEOPLE ARE REQUIRED TO REMOVE THE LEGS!**

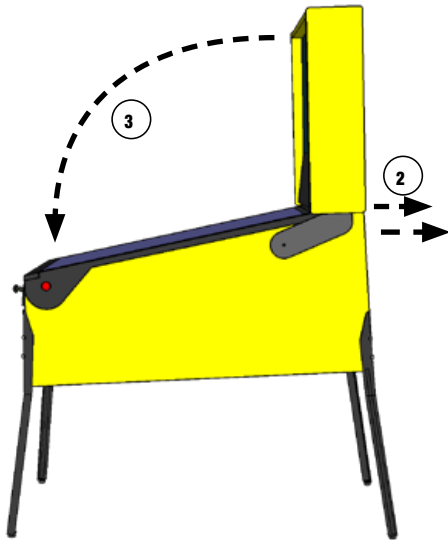

2. Remove the backbox securing bolts
3. Carefully lower the backbox onto the side rails. Use a piece of cardboard or suitable padding between the backbox and the game.

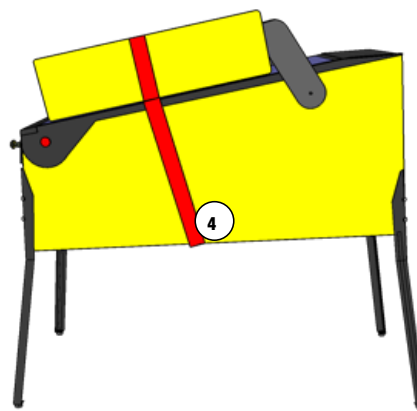

4. Securely strap the back box to the game
5. The game may be transported with the legs on. If the legs must be removed, follow the remaining steps.

## 2. REMOVE THE LEGS AND STAND UP

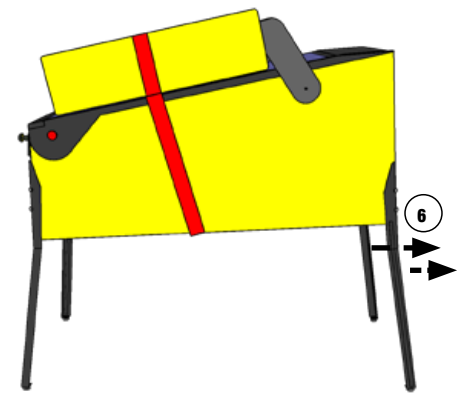

6. Remove the legs, rear legs first. Use a stool or a friend to support the rear of the game.
7. Rest the rear of the game on the ground.

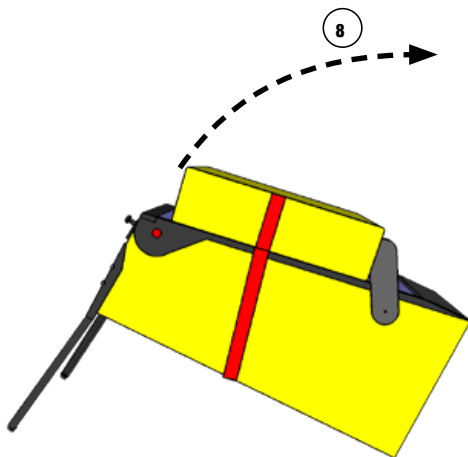

8. Stand the game up on its back.

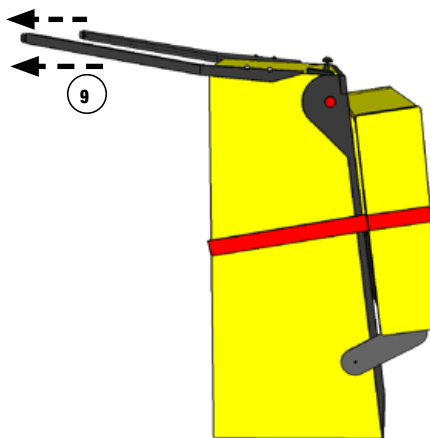

9. Remove the front two legs.

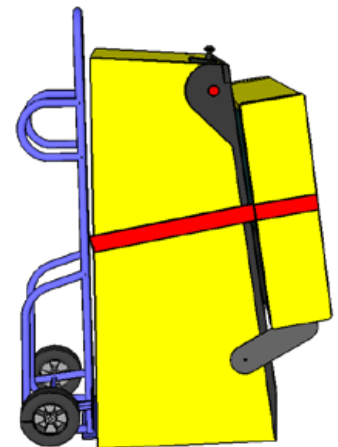

10. Secure all loose parts and transport with a hand truck in the upright position.

## 1.4 MAINTENANCE

### REGULAR MAINTENANCE - (MONTHLY/500 GAMES)

- Remove the playfield glass
- Enter the software diagnostics menu, start lamp test, then clean and wax the playfield.
  - While cleaning the playfield, identify and repair malfunctioning lights, loose parts, cracked plastics and worn rubber parts.
- While in diagnostics, enter the switch test (Select the "SW" Icon, then "TEST" Icon).
  - Use a pinball to actuate all switches and verify the correct switch registers with the switch test.
  - The game will play a sound to confirm the switch.
- Lift the playfield and inspect all assemblies for loose parts, broken wires or excessive wear. Look at the bottom of the cabinet for any parts that may have worked loose, then find the source.
- Check all coin door mechanisms and bill acceptor (if installed) for proper operation
- Play the game to ensure all coils and features are working
- Check the playfield to ensure it is level and set to the proper pitch using the bubble level on the right side wood rail.
- Check game audits: Replay % and Ball Time and note abnormal values which can indicate problems.
- Ensure game volume is set appropriately for the location.
- Clean both sides of the playfield glass and reinstall.
- Check and clean pinballs and replace if excessively worn or scuffed. Dirty pinballs accelerate game wear.

### OVERHAUL MAINTENANCE - (5000 GAMES)

- Verify latest game software is installed
- Check flippers for excessive wear. Excessive flipper sloppiness (vertical or horizontal) or weakness indicates a flipper rebuild is required.
- Clean machine inside and out and check leg levelers for free operation.
- Visual check for loose or broken playfield and cabinet parts and repair as necessary.
- Electrical check: Plug into grounded outlet and check for proper operation through DIAGNOSTICS.
- Replace worn or dirty rubbers.
- Replace pinballs.
- Check all playfield switches with a pinball.
- Check all settings (refer to manual for factory settings).
- Check coin door: With door closed, insert coins to verify proper operation.
- Check for proper adjustment of the plumb bob tilt.
- Play game: Check for satisfactory operation.

### COMMON PINBALL TOOLS

- Common nut drivers (1/4", 5/16", 11/32", 3/8")
- Phillips screwdriver
- Standard Allen wrench/Hex key set
- 3/8" Socket with ratchet
- Adjustable wrench (5/8" & 9/16")
- 6" Torpedo Level (or use a pinball)
- Flashlight or headlamp
- Soldering Iron (60w with flat tip), lead-free solder
- Wire cutter
- Wire stripper
- Long nose ("needle nose") pliers

## 1.5 MAINTENANCE KITS

Description	Part Number
Jaws LE Playfield Plastics Kit	803-5000-V6
Jaws Premium Playfield Plastics Kit	803-5000-V7
Jaws LE Playfield Decals Kit	802-5000-V6
Jaws Premium Playfield Decals Kit	802-5000-V7
Jaws LE Backbox Decal Left	820-90V6-01
Jaws Premium Backbox Decal Left	820-76V7-01
Jaws LE Backbox Decal Right	820-90V6-02
Jaws Premium Backbox Decal Right	820-76V7-02
Jaws LE Cabinet Decal Left	820-90V6-03
Jaws Premium Cabinet Decal Left	820-76V7-03
Jaws LE Cabinet Decal Right	820-90V6-04
Jaws Premium Cabinet Decal Right	820-76V7-04
Jaws LE Cabinet Decal Front	820-90V6-05
Jaws Premium Cabinet Decal Front	820-76V7-05
Jaws LE Playfield, Bare	830-5100-V6
Jaws Premium Playfield, Bare	830-5100-V7
Jaws LE Mirror Backglass	830-8426-V6
Jaws Premium Translite Backglass	830-8427-V7

## 1.6 COMMON PARTS

Description	Part Number
8 oz Pinball Playfield wax (Novus # 2)	675-0003-01
Standard Pinball, 1-1/16 in	260-5000-00
Flipper Rebuild Kit Left (Standard)	500-6307-10
Flipper Base Plate Kit Left	515-6617-01
Flipper Rebuild Kit Right	500-6307-00
Flipper Base Plate Kit Right	515-6617-00
Memory Card - SD 16GB	970-0140-16
Memory Card - MicroSD	970-0141-32
Wi-Fi Adapter	509-2013-00



## 2. SPIKE SYSTEM AND NODE GUIDE

### 2.1 SPIKE SYSTEM OVERVIEW

The SPIKE Pinball system is a rugged, distributed, and embedded platform custom-designed for the rigors of the pinball machine environment. SPIKE takes advantage of modern technologies to deliver an immersive pinball experience that supports modern features, reduces cabling, and increases serviceability and reliability.

A Stern Pinball machine based on the SPIKE system will have at least two nodes networked together with the SPIKE node bus, a custom industrial pinball control bus that is designed around industry standards and optimized for the pinball environment. The primary CPU node is networked to one or more input/output nodes over standard Category 5 UTP (unshielded twisted pair) ethernet cabling.

There are five primary types of nodes that are found in the game.

- CPU node (Node 0) - The primary node that controls other nodes in the system. Contains the primary game software for the system and provides SPIKE node bus power for other nodes.
- Cabinet 48V node (Node 1) - Specialized node with specific inputs and outputs for coin doors, tilt mechanisms, and other bottom-cabinet devices.
- 48V playfield node - Controls high power devices such as coils and flashers, and also supports a few switch and low-power outputs. Powered by the system 48V power supply.
- Light and switch node - High-density switch and low-power LED outputs, bus-powered from the node bus. These boards contain as many as 32 switch inputs and light outputs.
- Node extensions - These sub-nodes add additional low-power input and outputs to a specific Power or I/O node and are connected with simple serial bus.

### 2.2 NODE BUS CABLING

The SPIKE node bus utilizes standard Ethernet-style RJ45 8-pin modular jacks, and off-the-shelf Category 5e or better ethernet cabling. The node bus is electrically different from Ethernet and does not utilize Ethernet or TCP/IP protocols or signaling standards. SPIKE nodes are not compatible with standard computer networking equipment.

**CAUTION:** *Plugging a SPIKE Node or CPU board into a standard Ethernet port may damage one or both devices and void your warranty.*

### 2.3 SYSTEM POWER

The SPIKE System is powered from an 48V DC power supply bus. Each SPIKE node converts this voltage to lower voltages required by the node and its specific components. A SPIKE 48V node typically controls high-power outputs such as game coil mechanisms and high-brightness LEDs. These powered nodes are supplied directly with 48V system power. SPIKE standard I/O nodes are low-power nodes that read switch inputs and output to standard-brightness LEDs. Standard I/O nodes use the node bus power, which is supplied by the main CPU node over the node bus modular jack connectors.

### 2.4 SPIKE NODE ADDRESSES

Each SPIKE node has a unique address ranging from 0 to 15. Not all addresses are used in all games. Nodes can be of the same part number, so the address is specified on the DIP switches on each node. When replacing a node, be certain that the correct address is set. Nodes can have 3-position and 4-position DIP switches. Refer to the appropriate table to set the address for each type of Node. The correct address for a node can be found in the SPIKE node reference section of the manual or in the game diagnostic software. Address 0 is reserved for the backbox CPU node, where the game software resides. Address 1 is reserved for the cabinet node, located inside the coin door. These two nodes do not have DIP switches as their address is not configurable.

Address	1	2	3
8	OFF	OFF	OFF
9	OFF	OFF	ON
10	OFF	ON	OFF
11	OFF	ON	ON
12	ON	OFF	OFF
13	ON	OFF	ON
14	ON	ON	OFF
15	ON	ON	ON

SPIKE node addresses for nodes with 3-position DIP switches. Addresses 0-7 are not used by SPIKE nodes with 3-position DIP switches.

Address	1	2	3	4
8	OFF	OFF	OFF	OFF
9	OFF	OFF	ON	OFF
10	OFF	ON	OFF	OFF
11	OFF	ON	ON	OFF
12	ON	OFF	OFF	OFF
13	ON	OFF	ON	OFF
14	ON	ON	OFF	OFF
15	ON	ON	ON	OFF

SPIKE node addresses for nodes with 4-position DIP switches. Addresses 0-7 are reserved for fixed-function nodes and do not require configuration.

## **SPIKE SYSTEM AND NODE GUIDE CONTINUED**

### **2.5 SPIKE NODE PROGRAMMING**

The SPIKE nodes are smart nodes that have on-board processors and run embedded code. The nodes are programmed automatically by the CPU node whenever software updates are installed to the CPU. When replacing a node, the CPU node will detect and update the node to the latest software with no user intervention. Always replace nodes with the power to the game turned OFF.

### **2.6 SPIKE SYSTEM TERMINOLOGY**

#### **MULTI GENERAL ILLUMINATION LIGHTING**

General Illumination Lighting is two or more lights powered by one control source. These are often a number of LEDs connected in parallel and the system controls these as one large LED. A missing LED will not affect these circuits, however a shorted LED can cause the entire string of LEDs to turn off.

#### **SINGLE LIGHTS**

Single lights and LEDs are direct-controlled from SPIKE node boards. A common power source is grounded by individual transistors to turn individual LEDs on and off. Groups of LEDs, usually by node connector, share a common power source, so if a group of LEDs is out, check the wiring for the power source.

#### **FLASHERS**

SPIKE games treat flashers the same as single LEDs that draw more power. Flashers are controlled from the same circuits that power regular lights.

#### **DRIVERS**

A driver is a circuit that controls a high power-device such as a coil, magnet, or motor. Each device has a common 48V power source that is then connected to ground by a dedicated control transistor. Each driver is protected against shorting, static electricity, and over-current conditions. Take caution as 48V is always present on a device even when it is not energized.

#### **OPTOS**

Certain types of optical switches (“optos”) require external signal conditioning. For these optos, they will interface to a SPIKE node via an opto signal conditioning board. Other optical switches connect directly to the Spike node board.

*CAUTION: Unless explicitly directed by an Authorized Stern Repair technician, perform ALL work on your pinball machine with the power disabled!*

### **INPUT/OUTPUT PROTECTIONS**

SPIKE features built-in short-circuit, static electricity, and other protections to maximize reliability. If an LED, coil or other device shorts, it will be disabled but will not shut down the entire system in most circumstances. Groups of LEDs, coils, and switches often share common power supplies or other circuits, so it is possible that a bad device will affect the group of related devices and require removal or repair to fix the group. The system diagnostics will inform the technician of shorted or otherwise malfunctioning devices whenever possible. While the system is protected against permanent damage, it is strongly recommended to repair or replace these bad components as soon as possible to minimize downtime and maximize game earnings.

### **2.7 COMMON SPIKE NODE BOARDS**

<b>Description</b>	<b>Type</b>	<b>Part Number</b>
SPIKE CPU Node	Node	509-1003-01
Cabinet Node	Node	520-6967-72
Playfield 48V Core-Driver Node	Node	520-1057-00 520-1070-00
Trough Serial Opto Receiver Extension	Extension	520-8516-00

# 3. LIGHT, SWITCH, AND DRIVER REFERENCE

# JAWS

PREMIUM/LIMITED EDITION

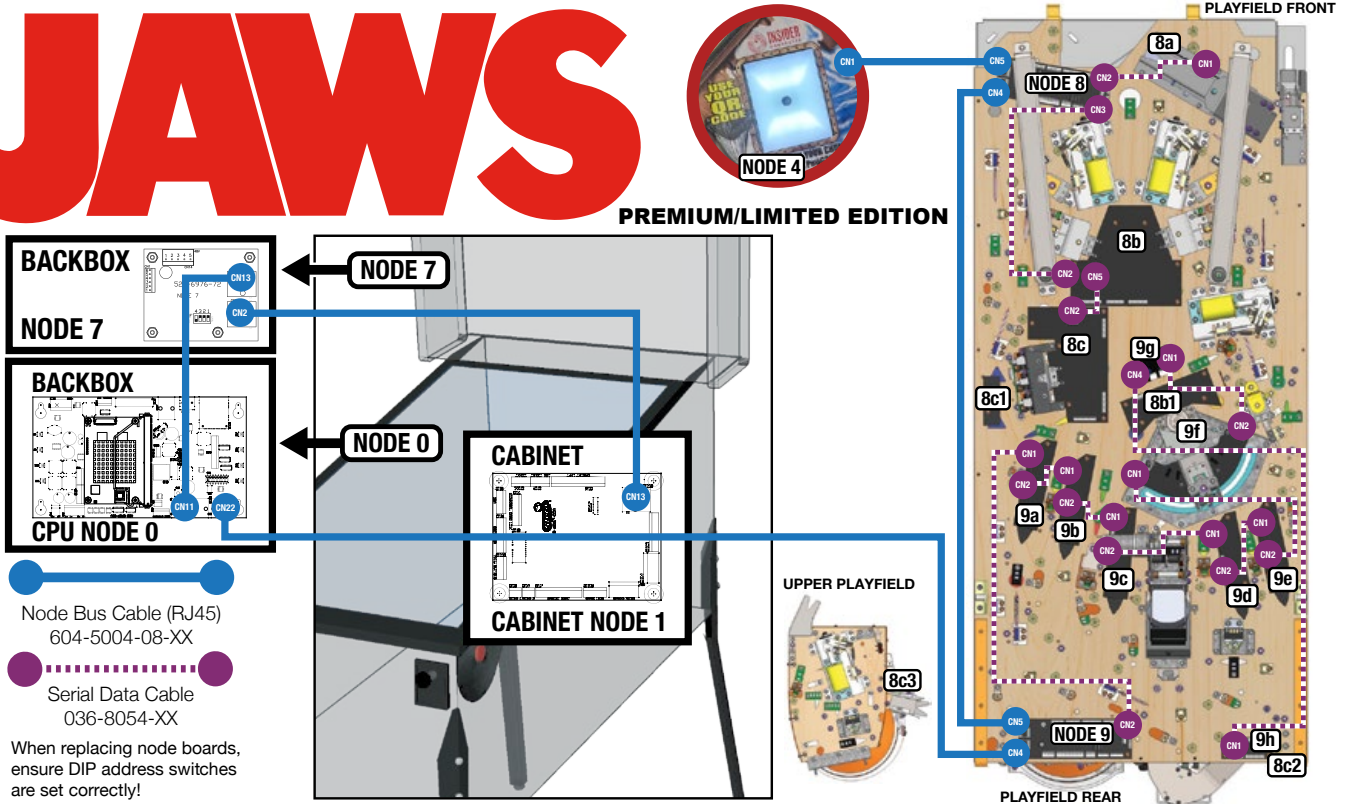

## 3.1 SPIKE NODE BOARDS

ID	DIP Address	Description	Location	Part Number
Node 0	n/a	SPIKE 2 CPU Node	Backbox	509-1003-01
Node 1	n/a	Cabinet Node	Cabinet	520-6967-72
Node 4	n/a	QR Reader Node	Bottom Arch	509-2020-00
Node 7	OFF-OFF-OFF-ON	SPI Node Board (LE Option)	Backbox-LEDs	520-5370-72
Node 8	OFF-OFF-OFF-OFF	Core - Driver Node (Playfield)	Lower Playfield	520-1070-00 520-1057-00
8a	n/a	Trough Serial Opto Receiver Extension	Playfield	520-8516-00
8b	n/a	Center LED Board	Playfield	520-1067-00
8b1	n/a	Lower Mid Right LED Board	Playfield	520-1066-00
8c	n/a	Left LED Board	Playfield	520-1068-00
8c1	n/a	3 LED Board	Playfield	520-7011-00
8c2	n/a	3 LED Board	Back Panel	520-7011-00
8c3	n/a	Billboard 4LED	Mini-Playfield	520-1076-00
Node 9	OFF-OFF-ON-OFF	Core - Driver Node (Playfield)	Playfield	520-1070-00 520-1057-00
9a	n/a	1 RGB 5 WHT LED Board	Playfield	520-1064-00
9b	n/a	1 RGB 5 WHT LED Board	Playfield	520-1064-00
9c	n/a	1 RGB 5 WHT LED Board	Playfield	520-1064-00
9d	n/a	1 RGB 5 WHT LED Board	Playfield	520-1064-00
9e	n/a	1 RGB 5 WHT LED Board	Playfield	520-1064-00
9f	n/a	Shark Fin LED SW Board	Playfield	520-1059-00
9g	n/a	Serial Motor Driver Board	Playfield	520-6996-00
9h	n/a	Serial 16 LED Board	Playfield	520-1087-00
Node 12	ON-OFF-OFF-OFF	SPI Node-PWM (Optional, Billboard Topper)	Topper	520-5370-72
Node 13	ON-OFF-ON-OFF	Core-Driver Node (Optional, Shark Attack Topper)	Topper	



**3.2 DRIVER REFERENCE**

ID	Name	Node	Connector	Ret. Pin	Ret. Wire	Voltage	V+ Pin	V+ Color	Location	Type	Address	Part Number
1	Trough	8	CN8	7	ORG GRY	48V	1-4	GRY ORG	Playfield	Coil - 27-1500	8-DR-1	090-5004-ND
2	Auto Plunger	8	CN8	9	ORG WHT	48V	1-4	GRY ORG	Playfield	Coil - 23-800	8-DR-4	090-5001-ND
3	Left Flipper	8	CN8	6	ORG YEL	48V	1-4	GRY ORG	Playfield	Coil - 22-1080	8-DR-5	090-5032-ND
4	Right Flipper	8	CN8	5	ORG GRN	48V	1-4	GRY ORG	Playfield	Coil - 22-1080	8-DR-0	090-5032-ND
5	Left Slingshot	8	CN8	11	ORG BLU	48V	1-4	GRY ORG	Playfield	Coil - 26-1200	8-DR-3	090-5044-ND
6	Right Slingshot	8	CN8	10	ORG VIO	48V	1-4	GRY ORG	Playfield	Coil - 26-1200	8-DR-2	090-5044-ND
7	Shaker Motor	1	CN16	1	BLU	48V	5	RED	Cabinet	Motor	1-DR-0	041-5029-04
8	Mid R Flip	8	CN7	3	YEL BLK	48V	1	GRY ORG	Playfield	Coil - 22-1080	8-DR-6	090-5032-ND
9	UP P/F R Flip	8	CN7	4	YEL BRN	48V	1	GRY ORG	Playfield	Coil - 22-1080	8-DR-7	090-5032-ND
10												
11												
12	Right Pop Bumper	9	CN8	11	ORG BRN	48V	1-4	GRY BRN	Playfield	Coil - 26-1200	9-DR-3	090-5044-ND
13	Shark Motor Up/Down	9	CN8	5	BRN RED	48V	1-4	GRY BRN	Playfield	Motor-041-5132-00	9-DR-0	511-1081-00
14	Shark Fin Up/Down	9	CN8	6	YEL VIO	48V	1-4	GRY BRN	Playfield	Coil - 26-1200	9-DR-5	500-7051-06 090-5091-00
15	Right Inlane Up Post	9	CN7	3	YELGRN	48V	1	GRY BRN	Playfield	Coil - 26-1200	9-DR-6	090-5044-ND
16	Left Inlane Up Post	9	CN7	4	YEL BLU	48V	1	GRY BRN	Playfield	Coil - 26-1200	9-DR-7	090-5044-ND
17	3 Bank Drop	9	CN8	7	YEL GRY	48V	1-4	GRY BRN	Playfield	Coil - 25-1240	9-DR-1	090-5034-ND
18												
19												
20												
21												
22												
23												
24												
25												
26												
27												
28												
29												
30												
31												
32												
33	Coin Meter	1	CN3	2	BLK	12V	1	RED	Cabinet	Digital Out	1-DR-2	500-9946-00
34	Ticket Meter	1	CN4	2	BLK	12V	1	RED	Cabinet	Digital Out	1-DR-3	500-9946-00
35	Ticket Dispenser	1	CN11	3		12V	1		Cabinet	Digital Out	1-DR-4	

Continued on next page...



DRIVER REFERENCE CONTINUED

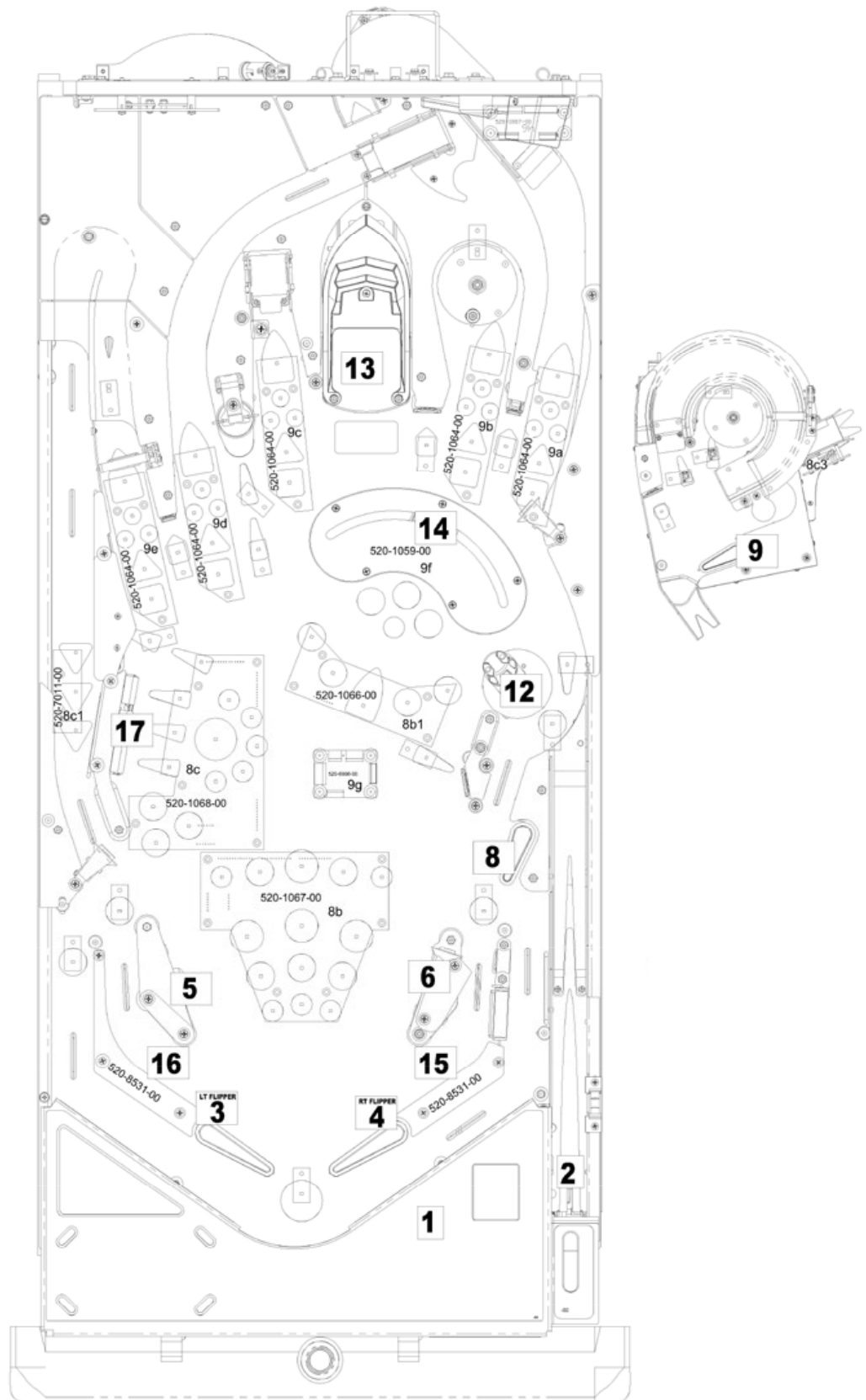

Figure 3.2.1. Playfield driver locations (top view).

### 3.3 SWITCH REFERENCE

ID	Name	Node	Node Ext	Conn.	Input Pin	Input Wire	GND Pin	Ground Wire	Location	Type	Address	Part Number
1	Left Outlane	9	-	CN11	4	LGN RED	11/12	BLK ORG	Playfield	Rollover	9-SW-17	500-9935-04
2	Left Return Lane	9	-	CN11	5	LGN ORG	11/12	BLK ORG	Playfield	Rollover	9-SW-18	500-9935-04
3	Bot R Outlane	9	-	CN11	8	LGN VIO	11/12	BLK ORG	Playfield	Rollover	9-SW-21	500-9935-04
4												
5	Right Return Lane	9	-	CN11	6	LGN YEL	11/12	BLK ORG	Playfield	Rollover	9-SW-19	500-9935-04
6	Right Outlane	9	-	CN11	7	LGN BLU	11/12	BLK ORG	Playfield	Rollover	9-SW-20	500-9935-04
7	Left Slingshot	8	-	CN10	4	GRY BLU	8	BLK GRN	Playfield	Leaf	8-SW-30	180-5231-00
8	Right Slingshot	8	-	CN10	3	GRY VIO	8	BLK GRN	Playfield	Leaf	8-SW-29	180-5231-00
9	Left Flipper Button	8	-	CN9	4	GRY BRN	7	BLK GRN	Cabinet	Leaf	8-SW-25	180-5160-01
10	Right Flipper Button	8	-	CN9	3	GRY RED	7	BLK GRN	Cabinet	Leaf	8-SW-24	180-5164-01
11	Left Flipper EOS	8	-	CN10	6	GRY YEL	9	BLK GRN	Playfield	Leaf	8-SW-16	180-5149-00
12	Right Flipper EOS	8	-	CN10	5	GRY GRN	9	BLK GRN	Playfield	Leaf	8-SW-31	180-5149-00
13												
14	UP Right Flipper Button	8	-	CN9	5	VIO WHT	7	BLK VIO	Playfield	Leaf	8-SW-26	180-5164-01
15	Trough 6	8	8a	CN14	-		-		Playfield	Opto	8-SW-32	520-5344-00 tx 520-8516-00 rx
16	Trough 5	8	8a	CN14	-		-		Playfield	Opto	8-SW-33	520-5344-00 tx 520-8516-00 rx
17	Trough 4	8	8a	CN14	-		-		Playfield	Opto	8-SW-34	520-5344-00 tx 520-8516-00 rx
18	Trough 3	8	8a	CN14	-		-		Playfield	Opto	8-SW-35	520-5344-00 tx 520-8516-00 rx
19	Trough 2	8	8a	CN14	-		-		Playfield	Opto	8-SW-36	520-5344-00 tx 520-8516-00 rx
20	Trough 1	8	8a	CN14	-		-		Playfield	Opto	8-SW-37	520-5344-00 tx 520-8516-00 rx
21	Trough Jam	8	8a	CN14	-		-		Playfield	Opto	8-SW-38	520-5344-00 tx 520-8516-00 rx
22	Shooter Lane	8	-	CN10	2	GRY WHT	7	BLK GRN	Playfield	Micro	8-SW-28	180-5157-01
23	MID Rt Flipper EOS	8	-	CN12	8	PNK BLK	10	BLK RED	Playfield	Leaf	8-SW-14	180-5149-00
24	UP Right Flipper EOS	8	-	CN12	9	PNK BRN	10	BLK RED	Playfield	Leaf	8-SW-15	180-5149-00
25												
26												
27												
28												
29												
30	Quickshot Bottom	8	-	CN12	2	WHT BRN	10	BLK RED	Playfield	Rollover	8-SW-8	500-9935-04
31	Bottom Rt Tgt	8	-	CN12	3	WHT RED	10	BLK RED	Playfield	Leaf/Target	8-SW-9	515-9783-00-00
32	Mid Flipper Lane	8	-	CN12	4	WHT ORG	10	BLK RED	Playfield	Rollover	8-SW-10	500-9935-04
33	Right Pop Bumper	9	-	CN10	3	GRY BRN	7/8/9	BLK BLU	Playfield	Leaf	9-SW-29	180-5232-00
34	Quickshot Gate	8	-	CN12	5	WHT YEL	10	BLK RED	Playfield	Micro	8-SW-11	180-5087-00
35												
36	3 Bank Bot	9	-	CN13	4	PNK YEL	10	BLK BRN	Playfield	Opto	9-SW-2	520-8497-00
37	3 Bank Mid	9	-	CN13	5	PNK GRN	10	BLK BRN	Playfield	Opto	9-SW-3	520-8497-00
38	3 Bank Top	9	-	CN13	6	PNK BLU	10	BLK BRN	Playfield	Opto	9-SW-4	520-8497-00
39												
40	Spinner Opto	9	-	CN10	6	GRY YEL	7/8/9	BLK BLU	Playfield	Opto	9-SW-16	520-8541-00
41	Quickshot Top	9	-	CN10	5	GRY ORG	7/8/9	BLK BLU	Playfield	Rollover	9-SW-31	500-9935-04
42	Quickshot Mid	9	-	CN10	4	GRY RED	7/8/9	BLK BLU	Playfield	Rollover	9-SW-30	500-9935-04
43	Left Loop Entrance	9	-	CN12	5	WHT YEL	10	BLK WHT	Playfield	Rollover	9-SW-11	500-9935-04
44												
45	Tgt 1	9	-	CN13	7	PNK VIO	10	BLK BRN	Playfield	Leaf/Target	9-SW-5	515-9785-00-00
46	Chum Bucket Tgt	9	-	CN11	9	LGN GRY	11/12	BLK ORG	Playfield	Leaf/Target	9-SW-22	515-9783-00-00

Continued on next page...



**SWITCH REFERENCE CONTINUED**

ID	Name	Node	Node Ext	Conn.	Input Pin	Input Wire	GND Pin	Ground Wire	Location	Type	Address	Part Number
47	Tgt 2	9	-	CN13	9	PNK WHT	10	BLK BRN	Playfield	Leaf/Target	9-SW-7	515-9783-00-00
48	Tgt 3	9	-	CN12	9	WHT GRY	10	BLK WHT	Playfield	Leaf/Target	9-SW-15	515-9785-00-00
49	Fishing Reel Mag Sw	9	-	CN11	10	LGN WHT	11/12	BLK ORG	Playfield	Opto	9-SW-23	520-8442-00
50												
51	Center Ramp Made	9	-	CN10	2	GRY BLK	7/8/9	BLK BLU	Playfield	Micro	9-SW-28	180-5087-00
52												
53												
54	Shark Fin Tgt	9	f	CN3	2	ORG	11/12	BLK	Playfield	Leaf/Target	9-SW-39	510-1059-00
55	Shark Position 1	9	f	SW7	-	-	-	-	Playfield	Opto	9-SW-38	520-1059-00
56	Shark Position 2	9	f	SW6	-	-	-	-	Playfield	Opto	9-SW-37	520-1059-00
57	Shark Position 3	9	f	SW5	-	-	-	-	Playfield	Opto	9-SW-36	520-1059-00
58	Shark Position 4	9	f	SW4	-	-	-	-	Playfield	Opto	9-SW-35	520-1059-00
59	Shark Position 5	9	f	SW3	-	-	-	-	Playfield	Opto	9-SW-34	520-1059-00
60	Shark Position 6	9	f	SW2	-	-	-	-	Playfield	Opto	9-SW-33	520-1059-00
61	Shark Position 7	9	f	SW1	-	-	-	-	Playfield	Opto	9-SW-32	520-1059-00
62												
63												
64	Boat Hit- Left Opto	9	-	CN12	2	WHT BRN	10	BLK WHT	Playfield	Opto	9-SW-8	520-1075-00 tx 520-5378-00 rx
65	Boat Hit- Center Opto	9	-	CN12	3	WHT RED	10	BLK WHT	Playfield	Opto	9-SW-9	520-1075-00 tx 520-5378-00 rx
66	Boat Hit- Right Opto	9	-	CN12	4	WHT ORG	10	BLK WHT	Playfield	Opto	9-SW-10	520-1075-00 tx 520-5378-00 rx
67												
68	Shark Up-Mag Sw	9	-	CN12	6	WHT GRN	10	BLK WHT	Playfield	Magnet	9-SW-12	520-8470-00
69	Shark Down-Mag Sw	9	-	CN12	7	WHT BLU	10	BLK WHT	Playfield	Magnet	9-SW-13	520-8470-00
70	Shark Hit	9	-	CN12	8	WHT VIO.	10	BLK WHT	Playfield	Micro	9-SW-14	180-5119-00
71	Left Ramp Enter	9	-	CN13	8	PNK GRY	10	BLK BRN	Playfield	Rollover	9-SW-6	500-9935-04
72	Left Ramp Made Opto	9	-	CN13	2	PNK RED	10	BLK BRN	Playfield	Opto	9-SW-0	520-8115-00 tx 520-8116-00 rx
73	Right Ramp Made Opto	9	-	CN13	3	PNK ORG	10	BLK BRN	Playfield	Opto	9-SW-1	515-0215-00 tx 515-0215-01 rx
74												
75												
76												
77												
78												
79												
80	Up PF Tgt	9	-	CN9	3	TAN BLK	7/8	BLK BLU	Playfield	Leaf/Target	9-SW-24	515-9783-00-00
81	Up PF Ship Wheel Mag	9	-	CN9	4	TAN VIO	7/8	BLK BLU	Playfield	Opto	9-SW-25	520-8442-00
82	UP PF Ramp Made	9	-	CN9	5	TAN WHT	7/8	BLK BLU	Playfield	Micro	9-SW-26	180-5087-00
83												
84												
85												
86												
87												
88												
89												
90	Lockdown Button	1	-	CN7	8	TAN WHT	5	BLK WHT	Cabinet	Leaf	1-SW-2	180-5218-00
91												
92												
93	Start Button	1	-	CN6	10	GRY	5	BLK WHT	Cabinet	Micro	1-SW-11	500-1060-44-LED

Continued on next page...



# LIGHT, SWITCH, AND DRIVER REFERENCE

## SWITCH REFERENCE CONTINUED

ID	Name	Node	Node Ext	Conn.	Input Pin	Input Wire	GND Pin	Ground Wire	Location	Type	Address	Part Number
94	Tournament Start Button	1	-	CN6	9	GRY WHT	5	BLK WHT	Cabinet	Micro	1-SW-12	500-6587-06-TL
95												
96	Left Coin	1	-	CN5	9	PNK BRN	3	BLK	Cabinet	Micro	1-SW-16	
97	Right Coin	1	-	CN5	7	PNK ORG	3	BLK	Cabinet	Micro	1-SW-18	
98	Center Coin	1	-	CN5	8	PNK RED	3	BLK	Cabinet	Micro	1-SW-17	
99	Fourth Coin	1	-	CN5	6		-		Cabinet	-	1-SW-19	
100	Fifth Coin	1	-	CN5	5		-		Cabinet	-	1-SW-20	
101	Tilt Pendulum	1	-	CN6	7	WHT	5	BLK WHT	Cabinet	Plumb Bob	1-SW-14	516-0007-00
102	Sixth Coin	1	-	CN9	5		-		Cabinet	-	1-SW-21	
103	Ticket Notch	1	-	CN11	5		-		Cabinet	-	1-SW-8	
104	Slam Tilt	1	-	CN5	4	LGN RED	3	BLK	Cabinet	-	1-SW-22	
105												
106												
107												
108												
109												
110												
C1	DIP 1	0	-	-	-		-		CPU Node		0-SW-0	-
C2	DIP 2	0	-	-	-		-		CPU Node		0-SW-1	-
C3	DIP 3	0	-	-	-		-		CPU Node		0-SW-2	-
C4	DIP 4	0	-	-	-		-		CPU Node		0-SW-3	-
C5	DIP 5	0	-	-	-		-		CPU Node		0-SW-4	-
C6	DIP 6	0	-	-	-		-		CPU Node		0-SW-5	-
C7	DIP 7	0	-	-	-		-		CPU Node		0-SW-6	-
C8	DIP 8	0	-	-	-		-		CPU Node		0-SW-7	-
C9	Service Select	0	-	CN25	4	LGN GRY	6	BLK	Coin Door		0-SW-8	515-1963-00
C10	Service Plus	0	-	CN25	3	LGN VIO	6	BLK	Coin Door		0-SW-9	515-1963-00
C11	Service Minus	0	-	CN25	2	LGN BLU	6	BLK	Coin Door		0-SW-10	515-1963-00
C12	Service Back	0	-	CN25	1	LGN BLK	6	BLK	Coin Door		0-SW-11	515-1963-00
C17	Headphone Detect	0	-	-	-		-		Coin Door		0-SW-16	-
C18	Headphone Kit Cable Detect	0	-	CN3	5	BLK	4	BLK	CPU Node		0-SW-17	-
C19	Volume Encoder 1	0	-	CN3	6	WHT	1	DRAIN	CPU Node		0-SW-18	-
C20	Volume Encoder 2	0	-	CN3	7	GRN	1	DRAIN	CPU Node		0-SW-19	-
C24	Coin Door Interlock	0	-	CN4	1	GRY	4	GRY RED	Backbox		0-SW-23	-

Continued on next page...





SWITCH REFERENCE CONTINUED

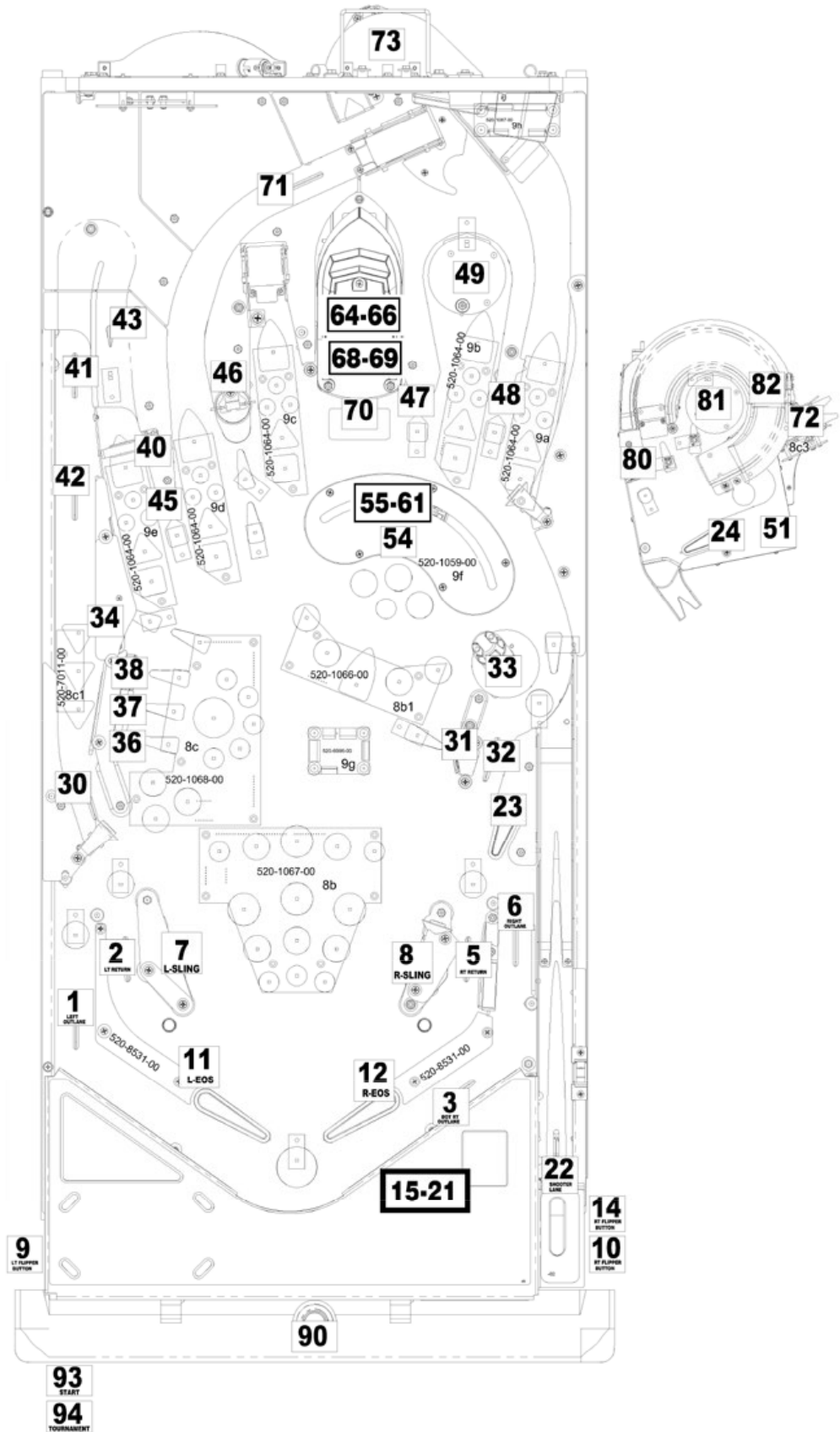

Figure 3.3.1. Playfield switch locations (top view).

### 3.4 LIGHT REFERENCE

ID	Name	Node	Node Ext.	Conn.	Ret. Pin	Ret. Wire	Src. Pin	Src. Wire	Location	Type	Light Color	Address	Part Number
1	Coin Enable	1	-	CN8	6	BLK GRY	2	GRY RED	Coin Door	Digital Out		1-LP-0	
2	Start Button	1	-	CN6	3	YEL BRN	1	RED	Cabinet	Feature	White	1-LP-2	113-5071-00
3	Tournament Start	1	-	CN6	2	YEL RED	1	RED	Cabinet	Feature	White	1-LP-3	112-5031-01
4	Lockdown Button-R	1	-	CN7	2	RED WHT	1	RED	Cabinet	Feature	RGB	1-LP-5	520-5333-00
5	Lockdown Button-G	1	-	CN7	3	GRN WHT	1	RED	Cabinet	Feature	RGB	1-LP-4	520-5333-00
6	Lockdown Button-B	1	-	CN7	4	BLU WHT	1	RED	Cabinet	Feature	RGB	1-LP-7	520-5333-00
7													
8													
9													
10													
11	Left Outlane	8	b	CN1	4	BRN RED	1/2/3	RED	Playfield	Feature	White	8-LP-9	520-5307-00
12	Left Return Lane	8	b	CN1	5	BRN ORG	1/2/3	RED	Playfield	Feature	White	8-LP-10	520-5307-00
13	Right Return Lane	8	b	CN1	7	BRN YEL	1/2/3	RED	Playfield	Feature	White	8-LP-12	520-5307-00
14													
15	Shoot Again	8	b	CN1	6	BRN VIO	1/2/3	RED	Playfield	Feature	White	8-LP-11	520-5307-00
16													
17	Left Return 1	8	b	CN1	8	YEL BRN	1/2/3	RED	Playfield	Feature	White	8-LP-13	520-8531-00
18	Left Return 2	8	b	CN1	9	YEL RED	1/2/3	RED	Playfield	Feature	White	8-LP-14	520-8531-00
19	Left Return 3	8	b	CN1	10	YEL ORG	1/2/3	RED	Playfield	Feature	White	8-LP-15	520-8531-00
20													
21	Right Return 1	8	b	CN1	11	YEL GRN	1/2/3	RED	Playfield	Feature	White	8-LP-16	520-8531-00
22	Right Return 2	8	b	CN1	12	YEL GRN	1/2/3	RED	Playfield	Feature	White	8-LP-17	520-8531-00
23	Right Return 3	8	b	CN1	13	YEL VIO	1/2/3	RED	Playfield	Feature	White	8-LP-18	520-8531-00
24													
25	Mako Shark	8	b	LED1	-	-	-	-	Playfield	Feature	White	8-LP-8	520-1067-00
26	Hammerhead Shark	8	b	LED12	-	-	-	-	Playfield	Feature	White	8-LP-19	520-1067-00
27	Great White	8	b	LED21	-	-	-	-	Playfield	Feature	White	8-LP-28	520-1067-00
28	Tiger Shark	8	b	LED30	-	-	-	-	Playfield	Feature	White	8-LP-37	520-1067-00
29	Thresher Shark	8	b	LED31	-	-	-	-	Playfield	Feature	White	8-LP-38	520-1067-00
30	Search	8	b	LED40	-	-	-	-	Playfield	Feature	White	8-LP-47	520-1067-00
31	4th of July	8	b	LED35	-	-	-	-	Playfield	Feature	White	8-LP-42	520-1067-00
32	Rescue	8	b	LED32	-	-	-	-	Playfield	Feature	White	8-LP-39	520-1067-00
33	Barrel Hook	8	b	LED39	-	-	-	-	Playfield	Feature	White	8-LP-46	520-1067-00
34	Shark Cage	8	b	LED36	-	-	-	-	Playfield	Feature	White	8-LP-43	520-1067-00
35	Dart	8	b	LED33	-	-	-	-	Playfield	Feature	White	8-LP-40	520-1067-00
36	Binoculars	8	b	LED38	-	-	-	-	Playfield	Feature	White	8-LP-45	520-1067-00
37	Oxygen	8	b	LED37	-	-	-	-	Playfield	Feature	White	8-LP-44	520-1067-00
38	Tracker	8	b	LED34	-	-	-	-	Playfield	Feature	White	8-LP-41	520-1067-00
39													
40													
41	Ready Barrel	8	c	LED38	-	-	-	-	Playfield	Feature	White	8-LP-85	520-1068-00
42	Pipit	8	c	LED40	-	-	-	-	Playfield	Feature	White	8-LP-87	520-1068-00
43	Light Machete	8	c	LED39	-	-	-	-	Playfield	Feature	White	8-LP-86	520-1068-00
44													
45	3 Bank Bottom	8	c	LED37	-	-	-	-	Playfield	Feature	White	8-LP-84	520-1068-00
46	3 Bank Mid	8	c	LED36	-	-	-	-	Playfield	Feature	White	8-LP-83	520-1068-00
47	3 Bank Top	8	c	LED35	-	-	-	-	Playfield	Feature	White	8-LP-82	520-1068-00
48	FF Super Buoys	8	c	LED10	-	-	-	-	Playfield	Feature	White	8-LP-57	520-1068-00
49	FF Super Life Ring	8	c	LED11	-	-	-	-	Playfield	Feature	White	8-LP-58	520-1068-00
50	FF Cast N Catch	8	c	LED12	-	-	-	-	Playfield	Feature	White	8-LP-59	520-1068-00
51	FF Light Video Mode	8	c	LED14	-	-	-	-	Playfield	Feature	White	8-LP-61	520-1068-00

Continued on next page...



LIGHT REFERENCE CONTINUED

ID	Name	Node	Node Ext.	Conn.	Ret. Pin	Ret. Wire	Src. Pin	Src. Wire	Location	Type	Light Color	Address	Part Number
52	FF Night Search	8	c	LED15	-	-	-	-	Playfield	Feature	White	8-LP-62	520-1068-00
53													
54	Quickshot	8	c	CN1	7	GRN BLU	1/2/3	RED	Playfield	Feature	White	8-LP-51	520-5307-00
55	Harpoon	8	c	LED34	-	-	-	-	Playfield	Feature	White	8-LP-81	520-1068-00
56													
57	Quickshot 1X	8	c	CN1	4	GRN RED	1/2/3	RED	Playfield	Feature	White	8-LP-48	520-7011-00
58	Quickshot 2X	8	c	CN1	5	GRN ORG	1/2/3	RED	Playfield	Feature	White	8-LP-49	520-7011-00
59	Quickshot 4X	8	c	CN1	6	GRN YEL	1/2/3	RED	Playfield	Feature	White	8-LP-50	520-7011-00
60													
61	Collect Quickshot	8	b	CN4	4	BLU BRN	1/2/3	RED	Playfield	Feature	White	8-LP-29	520-1066-00
62	Attach Barrel	8	b	CN4	5	BLU RED	1/2/3	RED	Playfield	Feature	White	8-LP-30	520-1066-00
63	Fin R	8	b	CN4	6	RED GRY	1/2/3	RED	Playfield	Feature	RGB	8-LP-31	520-1066-00
64	Fin G	8	b	CN4	7	GRN GRY	1/2/3	RED	Playfield	Feature	RGB	8-LP-32	520-1066-00
65	Fin B	8	b	CN4	8	BLU GRY	1/2/3	RED	Playfield	Feature	RGB	8-LP-33	520-1066-00
66	Encounter Jackpot	8	b	CN4	9	BLU ORG	1/2/3	RED	Playfield	Feature	White	8-LP-34	520-1066-00
67	Extra Ball	8	b	CN4	10	BLU GRN	1/2/3	RED	Playfield	Feature	White	8-LP-35	520-1066-00
68													
69	Barrel 1	9	f	LED1	-	-	-	-	Playfield	Feature	White	9-LP-48	520-1059-00
70	Barrel 2	9	f	LED7	-	-	-	-	Playfield	Feature	White	9-LP-64	520-1059-00
71	Barrel 3	9	f	LED10	-	-	-	-	Playfield	Feature	White	9-LP-71	520-1059-00
72													
73	Fin Target 1-R	9	f	LED3	-	-	-	-	Playfield	Feature	RGB	9-LP-52	520-1059-00
74	Fin Target 1-G	9	f	LED3	-	-	-	-	Playfield	Feature	RGB	9-LP-53	520-1059-00
75	Fin Target 1-B	9	f	LED3	-	-	-	-	Playfield	Feature	RGB	9-LP-54	520-1059-00
76	Fin Target 2-R	9	f	LED2	-	-	-	-	Playfield	Feature	RGB	9-LP-49	520-1059-00
77	Fin Target 2-G	9	f	LED2	-	-	-	-	Playfield	Feature	RGB	9-LP-50	520-1059-00
78	Fin Target 2-B	9	f	LED2	-	-	-	-	Playfield	Feature	RGB	9-LP-51	520-1059-00
79	Fin Target 3-R	9	f	LED4	-	-	-	-	Playfield	Feature	RGB	9-LP-55	520-1059-00
80	Fin Target 3-G	9	f	LED4	-	-	-	-	Playfield	Feature	RGB	9-LP-56	520-1059-00
81	Fin Target 3-B	9	f	LED4	-	-	-	-	Playfield	Feature	RGB	9-LP-57	520-1059-00
82	Fin Target 4-R	9	f	LED6	-	-	-	-	Playfield	Feature	RGB	9-LP-61	520-1059-00
83	Fin Target 4-G	9	f	LED6	-	-	-	-	Playfield	Feature	RGB	9-LP-62	520-1059-00
84	Fin Target 4-B	9	f	LED6	-	-	-	-	Playfield	Feature	RGB	9-LP-63	520-1059-00
85	Fin Target 5-R	9	f	LED5	-	-	-	-	Playfield	Feature	RGB	9-LP-58	520-1059-00
86	Fin Target 5-G	9	f	LED5	-	-	-	-	Playfield	Feature	RGB	9-LP-59	520-1059-00
87	Fin Target 5-B	9	f	LED5	-	-	-	-	Playfield	Feature	RGB	9-LP-60	520-1059-00
88	Fin Target 6-R	9	f	LED9	-	-	-	-	Playfield	Feature	RGB	9-LP-68	520-1059-00
89	Fin Target 6-G	9	f	LED9	-	-	-	-	Playfield	Feature	RGB	9-LP-69	520-1059-00
90	Fin Target 6-B	9	f	LED9	-	-	-	-	Playfield	Feature	RGB	9-LP-70	520-1059-00
91	Fin Target 7-R	9	f	LED8	-	-	-	-	Playfield	Feature	RGB	9-LP-65	520-1059-00
92	Fin Target 7-G	9	f	LED8	-	-	-	-	Playfield	Feature	RGB	9-LP-66	520-1059-00
93	Fin Target 7-B	9	f	LED8	-	-	-	-	Playfield	Feature	RGB	9-LP-67	520-1059-00
94													
95	Advance Bounty Right	8	b	CN3	7	GRN RED	1/2/3	RED	Playfield	Feature	White	8-LP-23	520-5307-00
96	Activate Fishfinder	8	b	CN3	8	GRN ORG	1/2/3	RED	Playfield	Feature	White	8-LP-24	520-5307-00
97	Light Life Ring	8	b	CN3	9	GRN YEL	1/2/3	RED	Playfield	Feature	White	8-LP-25	520-5307-00
98													
99	West Beach R	9	a	LED1	-	-	-	-	Playfield	Feature	RGB	9-LP-8	520-1064-00
100	West Beach G	9	a	LED1	-	-	-	-	Playfield	Feature	RGB	9-LP-9	520-1064-00
101	West Beach B	9	a	LED1	-	-	-	-	Playfield	Feature	RGB	9-LP-10	520-1064-00
102	West Beach Rescue Top	9	a	LED2	-	-	-	-	Playfield	Feature	White	9-LP-11	520-1064-00

Continued on next page...



# LIGHT, SWITCH, AND DRIVER REFERENCE

## LIGHT REFERENCE CONTINUED

ID	Name	Node	Node Ext.	Conn.	Ret. Pin	Ret. Wire	Src. Pin	Src. Wire	Location	Type	Light Color	Address	Part Number
103	West Beach Rescue Left	9	a	LED3	-	-	-	-	Playfield	Feature	White	9-LP-12	520-1064-00
104	West Beach Rescue Right	9	a	LED4	-	-	-	-	Playfield	Feature	White	9-LP-13	520-1064-00
105	West Beach Shark	9	a	LED5	-	-	-	-	Playfield	Feature	White	9-LP-14	520-1064-00
106	West Beach Closed X	9	a	LED6	-	-	-	-	Playfield	Feature	White	9-LP-15	520-1064-00
107													
108	Target 1	8	b	CN4	11	BLU VIO	1/2/3	RED	Playfield	Feature	White	8-LP-36	520-5307-00
109													
110	Marina R	9	b	LED1	-	-	-	-	Playfield	Feature	RGB	9-LP-16	520-1064-00
111	Marina G	9	b	LED1	-	-	-	-	Playfield	Feature	RGB	9-LP-17	520-1064-00
112	Marina B	9	b	LED1	-	-	-	-	Playfield	Feature	RGB	9-LP-18	520-1064-00
113	Marina Rescue Top	9	b	LED2	-	-	-	-	Playfield	Feature	White	9-LP-19	520-1064-00
114	Marina Rescue Left	9	b	LED3	-	-	-	-	Playfield	Feature	White	9-LP-20	520-1064-00
115	Marina Rescue Right	9	b	LED4	-	-	-	-	Playfield	Feature	White	9-LP-21	520-1064-00
116	Marina Shark	9	b	LED5	-	-	-	-	Playfield	Feature	White	9-LP-22	520-1064-00
117	Marina Closed X	9	b	LED6	-	-	-	-	Playfield	Feature	White	9-LP-23	520-1064-00
118													
119	Chumline Advance	8	c	CN1	8	GRN VIO	1/2/3	RED	Playfield	Feature	White	8-LP-52	520-5307-00
120	Advance Bounty Left	8	c	CN1	9	GRN GRY	1/2/3	RED	Playfield	Feature	White	8-LP-53	520-5307-00
121													
122	North Beach R	9	c	LED1	-	-	-	-	Playfield	Feature	RGB	9-LP-24	520-1064-00
123	North Beach G	9	c	LED1	-	-	-	-	Playfield	Feature	RGB	9-LP-25	520-1064-00
124	North Beach B	9	c	LED1	-	-	-	-	Playfield	Feature	RGB	9-LP-26	520-1064-00
125	North Beach Rescue Top	9	c	LED2	-	-	-	-	Playfield	Feature	White	9-LP-27	520-1064-00
126	North Beach Rescue Left	9	c	LED3	-	-	-	-	Playfield	Feature	White	9-LP-28	520-1064-00
127	North Beach Rescue Right	9	c	LED4	-	-	-	-	Playfield	Feature	White	9-LP-29	520-1064-00
128	North Beach Shark	9	c	LED5	-	-	-	-	Playfield	Feature	White	9-LP-30	520-1064-00
129	North Beach Closed X	9	c	LED6	-	-	-	-	Playfield	Feature	White	9-LP-31	520-1064-00
130													
131	Boat Hit Left	9	-	CN14	6	YEL BLU	7/8	YEL	Playfield	Feature	White	9-LP-3	520-1075-00
132	Boat Hit Center	9	-	CN14	5	YEL VIO	7/8	YEL	Playfield	Feature	White	9-LP-4	520-1075-00
133	Boat Hit Right	9	-	CN14	4	YEL GRY	7/8	YEL	Playfield	Feature	White	9-LP-5	520-1075-00
134													
135	Target 2	8	b	CN3	10	GRN BLU	1/2/3	RED	Playfield	Feature	White	8-LP-26	520-5307-00
136	Target 3	8	b	CN3	11	GRN VIO	1/2/3	RED	Playfield	Feature	White	8-LP-27	520-5307-00
137													
138	The Pond R	9	d	LED1	-	-	-	-	Playfield	Feature	RGB	9-LP-32	520-1064-00
139	The Pond G	9	d	LED1	-	-	-	-	Playfield	Feature	RGB	9-LP-33	520-1064-00
140	The Pond B	9	d	LED1	-	-	-	-	Playfield	Feature	RGB	9-LP-34	520-1064-00
141	The Pond Rescue Top	9	d	LED2	-	-	-	-	Playfield	Feature	White	9-LP-35	520-1064-00
142	The Pond Rescue Left	9	d	LED3	-	-	-	-	Playfield	Feature	White	9-LP-36	520-1064-00
143	The Pond Rescue Right	9	d	LED4	-	-	-	-	Playfield	Feature	White	9-LP-37	520-1064-00
144	The Pond Shark	9	d	LED5	-	-	-	-	Playfield	Feature	White	9-LP-38	520-1064-00
145	The Pond Closed X	9	d	LED6	-	-	-	-	Playfield	Feature	White	9-LP-39	520-1064-00
146													
147	East Beach R	9	e	LED1	-	-	-	-	Playfield	Feature	RGB	9-LP-40	520-1064-00
148	East Beach G	9	e	LED1	-	-	-	-	Playfield	Feature	RGB	9-LP-41	520-1064-00
149	East Beach B	9	e	LED1	-	-	-	-	Playfield	Feature	RGB	9-LP-42	520-1064-00
150	East Beach Rescue Top	9	e	LED2	-	-	-	-	Playfield	Feature	White	9-LP-43	520-1064-00
151	East Beach Rescue Left	9	e	LED3	-	-	-	-	Playfield	Feature	White	9-LP-44	520-1064-00
152	East Beach Rescue Right	9	e	LED4	-	-	-	-	Playfield	Feature	White	9-LP-45	520-1064-00
153	East Beach Shark	9	e	LED5	-	-	-	-	Playfield	Feature	White	9-LP-46	520-1064-00

Continued on next page...



LIGHT REFERENCE CONTINUED

ID	Name	Node	Node Ext.	Conn.	Ret. Pin	Ret. Wire	Src. Pin	Src. Wire	Location	Type	Light Color	Address	Part Number
154	East Beach Closed X	9	e	LED6	-	-	-	-	Playfield	Feature	White	9-LP-47	520-1064-00
155													
156	Orca BB Left	8	c	CN3	12	YEL RED	1/2/3/4	RED	Playfield	Feature	White	8-LP-70	520-5307-00
157	Orca BB Right	8	c	CN3	13	YEL BRN	1/2/3/4	RED	Playfield	Feature	White	8-LP-71	520-5307-00
158													
159	Shark BB 1 Top	8	c	CN5	8	BRN BLU	1/2/3/4	RED	Playfield	Feature	White	8-LP-75	520-1076-00
160	Shark BB 2	8	c	CN5	9	BRN VIO	1/2/3/4	RED	Playfield	Feature	White	8-LP-76	520-1076-00
161	Shark BB 3	8	c	CN5	10	BRN	1/2/3/4	RED	Playfield	Feature	White	8-LP-77	520-1076-00
162	Shark BB 4 Bot	8	c	CN5	11	BRN WHT	1/2/3/4	RED	Playfield	Feature	White	8-LP-78	520-1076-00
163													
164	Quints BB 1 Top	8	c	CN3	9	YEL WHT	1/2/3/4	RED	Playfield	Feature	White	8-LP-67	520-7011-00
165	Quints BB 2 Mid	8	c	CN3	10	YEL GRN	1/2/3/4	RED	Playfield	Feature	White	8-LP-68	520-7011-00
166	Quints BB 3 Bot	8	c	CN3	11	YEL ORG	1/2/3/4	RED	Playfield	Feature	White	8-LP-69	520-7011-00
167													
168													
169													
170	Upper PF Ramp R	9	h	CN2	7	RED ORG	8/9	RED	Playfield	Feature	RGB	9-LP-80	520-5333-00
171	Upper PF Ramp G	9	h	CN2	6	GRN ORG	8/9	RED	Playfield	Feature	RGB	9-LP-81	520-5333-00
172	Upper PF Ramp B	9	h	CN2	5	BLU ORG	8/9	RED	Playfield	Feature	RGB	9-LP-82	520-5333-00
173	Upper PF Ship Wheel R	9	h	CN2	4	RED BRN	8/9	RED	Playfield	Feature	RGB	9-LP-83	520-5333-00
174	Upper PF Ship Wheel G	9	h	CN2	3	GRN BRN	8/9	RED	Playfield	Feature	RGB	9-LP-84	520-5333-00
175	Upper PF Ship Wheel B	9	h	CN2	2	BLU BRN	8/9	RED	Playfield	Feature	RGB	9-LP-85	520-5333-00
176	Upper PF Radio	9	h	CN2	1	YEL BRN	8/9	RED	Playfield	Feature	White	9-LP-86	520-5307-00
177													
178													
179													
180	Coin Door Gl	1	-	CN5	2	YEL	1	YEL-WHT	Coin Door	G.I.	White	1-LP-1	112-5033-08
181	Bottom Gl (x6)	8	-	CN15	5	WHT BLK	1	YEL BLK	Playfield	G.I.	White	8-LP-0	112-5034-08F
182	Top Gl (x8)	8		CN15	6	RED BLK	2	YEL RED	Playfield	G.I.	White	8-LP-1	112-5034-08F
183	Bottom Arch Gl (x3)	8		CN15	7	BLU BLK	3	YEL BLU	Playfield	G.I.	White	8-LP-2	520-7000-00 520-5307-00
184													
185	Top Gl-RED (x8)	9	-	CN15	5	RED BLK	1	YEL	Playfield	G.I.	RGB	9-LP-0	520-5333-00
186	Top Gl-GRN (x8)	9		CN15	6	GRN BLK	1	YEL	Playfield	G.I.	RGB	9-LP-1	520-5333-00
187	Top Gl-BLU (x8)	9		CN15	7	BLU BLK	1	YEL	Playfield	G.I.	RGB	9-LP-2	520-5333-00
188													
189	Mid Right Spotlight	8	c	CN1	12	ORG WHT	1/2/3	RED	Playfield	Flash	White	8-LP-56	113-5032-08
190	Lower Left Spotlight	8	b	CN3	4	ORG BRN	1/2/3	RED	Playfield	Flash	White	8-LP-20	113-5032-08
191	Lower Right Spotlight	8	b	CN3	5	ORG RED	1/2/3	RED	Playfield	Flash	White	8-LP-21	113-5032-08
192	Fish Finder Multiball Flash	8	b	LED13	-	-	-	-	Playfield	Flash	White	8-LP-60	520-1068-00
193	Pop Bumper	8	b	CN3	6	BRN	1/2/3	RED	Playfield	Flash	White	8-LP-22	520-8059-00
194													
195	West Beach Flasher	8	c	CN1	10	ORG BLU	1/2/3	RED	Playfield	Flash	White	8-LP-54	520-7000-00
196	Boat Flash	8	c	CN3	8	ORG GRN	1/2/3/4	RED	Playfield	Flash	White	8-LP-66	520-7000-00
197	Fishing Reel Flash	8	c	CN1	11	ORG VIO	1/2/3	RED	Playfield	Flash	White	8-LP-55	520-7000-00
198													
199	Backpanel Ramp Flash	8	c	CN5	5	ORG BRN	1/2/3/4	RED	Playfield	Flash	White	8-LP-72	113-5045-08
200	Backpanel Center Flash (2x)	8	c	CN5	6	ORG RED	1/2/3/4	RED	Playfield	Flash	White	8-LP-73	520-7000-00
201	Backpanel Right Flash	8	c	CN5	7	ORG YEL	1/2/3/4	RED	Playfield	Flash	White	8-LP-74	520-7000-00
202													
203	Upper PF Flash	9	h	CN1	8	ORG GRY	10/11/12	RED	Playfield	Flash	White	9-LP-88	520-7000-00
204	Upper PF Ship Wheel Flash	9	h	CN1	9	ORG	10/11/12	RED	Playfield	Flash	White	9-LP-87	520-7000-00

Continued on next page...



**LIGHT REFERENCE CONTINUED**

ID	Name	Node	Node Ext.	Conn.	Ret. Pin	Ret. Wire	Src. Pin	Src. Wire	Location	Type	Light Color	Address	Part Number
205													
206													
207													
208													
209													
210													
211													
212													
213													
214													
215													
216													
217													
218													
219													
220	Speaker 1-R	7	-	CN1	-	-	-	-	Cabinet	Feature	RGB	7-LP-1	511-1135-00
221	Speaker 1-G	7	-	CN1	-	-	-	-	Cabinet	Feature	RGB	7-LP-0	511-1135-00
222	Speaker 1-B	7	-	CN1	-	-	-	-	Cabinet	Feature	RGB	7-LP-2	511-1135-00
223	Speaker 2-R	7	-	CN1	-	-	-	-	Cabinet	Feature	RGB	7-LP-4	511-1135-00
224	Speaker 2-G	7	-	CN1	-	-	-	-	Cabinet	Feature	RGB	7-LP-3	511-1135-00
225	Speaker 2-B	7	-	CN1	-	-	-	-	Cabinet	Feature	RGB	7-LP-5	511-1135-00
226	Speaker 3-R	7	-	CN1	-	-	-	-	Cabinet	Feature	RGB	7-LP-7	511-1135-00
227	Speaker 3-G	7	-	CN1	-	-	-	-	Cabinet	Feature	RGB	7-LP-6	511-1135-00
228	Speaker 3-B	7	-	CN1	-	-	-	-	Cabinet	Feature	RGB	7-LP-8	511-1135-00
229	Speaker 4-R	7	-	CN1	-	-	-	-	Cabinet	Feature	RGB	7-LP-10	511-1135-00
230	Speaker 4-G	7	-	CN1	-	-	-	-	Cabinet	Feature	RGB	7-LP-9	511-1135-00
231	Speaker 4-B	7	-	CN1	-	-	-	-	Cabinet	Feature	RGB	7-LP-11	511-1135-00
232	Speaker 5-R	7	-	CN1	-	-	-	-	Cabinet	Feature	RGB	7-LP-13	511-1135-00
233	Speaker 5-G	7	-	CN1	-	-	-	-	Cabinet	Feature	RGB	7-LP-12	511-1135-00
234	Speaker 5-B	7	-	CN1	-	-	-	-	Cabinet	Feature	RGB	7-LP-14	511-1135-00
235	Speaker 6-R	7	-	CN1	-	-	-	-	Cabinet	Feature	RGB	7-LP-16	511-1135-00
236	Speaker 6-G	7	-	CN1	-	-	-	-	Cabinet	Feature	RGB	7-LP-15	511-1135-00
237	Speaker 6-B	7	-	CN1	-	-	-	-	Cabinet	Feature	RGB	7-LP-17	511-1135-00
238	Speaker 7-R	7	-	CN1	-	-	-	-	Cabinet	Feature	RGB	7-LP-19	511-1135-00
239	Speaker 7-G	7	-	CN1	-	-	-	-	Cabinet	Feature	RGB	7-LP-18	511-1135-00
240	Speaker 7-B	7	-	CN1	-	-	-	-	Cabinet	Feature	RGB	7-LP-20	511-1135-00
241	Speaker 8-R	7	-	CN1	-	-	-	-	Cabinet	Feature	RGB	7-LP-22	511-1135-00
242	Speaker 8-G	7	-	CN1	-	-	-	-	Cabinet	Feature	RGB	7-LP-21	511-1135-00
243	Speaker 8-B	7	-	CN1	-	-	-	-	Cabinet	Feature	RGB	7-LP-23	511-1135-00
244	Speaker 9-R	7	-	CN1	-	-	-	-	Cabinet	Feature	RGB	7-LP-25	511-1135-00
245	Speaker 9-G	7	-	CN1	-	-	-	-	Cabinet	Feature	RGB	7-LP-24	511-1135-00
246	Speaker 9-B	7	-	CN1	-	-	-	-	Cabinet	Feature	RGB	7-LP-26	511-1135-00
247	Speaker 10-R	7	-	CN1	-	-	-	-	Cabinet	Feature	RGB	7-LP-28	511-1135-00
248	Speaker 10-G	7	-	CN1	-	-	-	-	Cabinet	Feature	RGB	7-LP-27	511-1135-00
249	Speaker 10-B	7	-	CN1	-	-	-	-	Cabinet	Feature	RGB	7-LP-29	511-1135-00
250	Speaker 11-R	7	-	CN1	-	-	-	-	Cabinet	Feature	RGB	7-LP-31	511-1135-00
251	Speaker 11-G	7	-	CN1	-	-	-	-	Cabinet	Feature	RGB	7-LP-30	511-1135-00
252	Speaker 11-B	7	-	CN1	-	-	-	-	Cabinet	Feature	RGB	7-LP-32	511-1135-00
253	Speaker 12-R	7	-	CN1	-	-	-	-	Cabinet	Feature	RGB	7-LP-34	511-1135-00
254	Speaker 12-G	7	-	CN1	-	-	-	-	Cabinet	Feature	RGB	7-LP-33	511-1135-00
255	Speaker 12-B	7	-	CN1	-	-	-	-	Cabinet	Feature	RGB	7-LP-35	511-1135-00

Continued on next page...



LIGHT REFERENCE CONTINUED

ID	Name	Node	Node Ext.	Conn.	Ret. Pin	Ret. Wire	Src. Pin	Src. Wire	Location	Type	Light Color	Address	Part Number
256	Speaker 13-R	7	-	CN1	-	-	-	-	Cabinet	Feature	RGB	7-LP-37	511-1135-00
257	Speaker 13-G	7	-	CN1	-	-	-	-	Cabinet	Feature	RGB	7-LP-36	511-1135-00
258	Speaker 13-B	7	-	CN1	-	-	-	-	Cabinet	Feature	RGB	7-LP-38	511-1135-00
259	Speaker 14-R	7	-	CN1	-	-	-	-	Cabinet	Feature	RGB	7-LP-40	511-1135-00
260	Speaker 14-G	7	-	CN1	-	-	-	-	Cabinet	Feature	RGB	7-LP-39	511-1135-00
261	Speaker 14-B	7	-	CN1	-	-	-	-	Cabinet	Feature	RGB	7-LP-41	511-1135-00
262	Speaker 15-R	7	-	CN1	-	-	-	-	Cabinet	Feature	RGB	7-LP-43	511-1135-00
263	Speaker 15-G	7	-	CN1	-	-	-	-	Cabinet	Feature	RGB	7-LP-42	511-1135-00
264	Speaker 15-B	7	-	CN1	-	-	-	-	Cabinet	Feature	RGB	7-LP-44	511-1135-00
265	Speaker 16-R	7	-	CN1	-	-	-	-	Cabinet	Feature	RGB	7-LP-46	511-1135-00
266	Speaker 16-G	7	-	CN1	-	-	-	-	Cabinet	Feature	RGB	7-LP-45	511-1135-00
267	Speaker 16-B	7	-	CN1	-	-	-	-	Cabinet	Feature	RGB	7-LP-47	511-1135-00
268	Speaker 17-R	7	-	CN1	-	-	-	-	Cabinet	Feature	RGB	7-LP-49	511-1135-00
269	Speaker 17-G	7	-	CN1	-	-	-	-	Cabinet	Feature	RGB	7-LP-48	511-1135-00
270	Speaker 17-B	7	-	CN1	-	-	-	-	Cabinet	Feature	RGB	7-LP-50	511-1135-00
271	Speaker 18-R	7	-	CN1	-	-	-	-	Cabinet	Feature	RGB	7-LP-52	511-1135-00
272	Speaker 18-G	7	-	CN1	-	-	-	-	Cabinet	Feature	RGB	7-LP-51	511-1135-00
273	Speaker 18-B	7	-	CN1	-	-	-	-	Cabinet	Feature	RGB	7-LP-53	511-1135-00
274	Speaker 19-R	7	-	CN1	-	-	-	-	Cabinet	Feature	RGB	7-LP-55	511-1135-00
275	Speaker 19-G	7	-	CN1	-	-	-	-	Cabinet	Feature	RGB	7-LP-54	511-1135-00
276	Speaker 19-B	7	-	CN1	-	-	-	-	Cabinet	Feature	RGB	7-LP-56	511-1135-00
277	Speaker 20-R	7	-	CN1	-	-	-	-	Cabinet	Feature	RGB	7-LP-58	511-1135-00
278	Speaker 20-G	7	-	CN1	-	-	-	-	Cabinet	Feature	RGB	7-LP-57	511-1135-00
279	Speaker 20-B	7	-	CN1	-	-	-	-	Cabinet	Feature	RGB	7-LP-59	511-1135-00
280	Speaker 21-R	7	-	CN1	-	-	-	-	Cabinet	Feature	RGB	7-LP-61	511-1135-00
281	Speaker 21-G	7	-	CN1	-	-	-	-	Cabinet	Feature	RGB	7-LP-60	511-1135-00
282	Speaker 21-B	7	-	CN1	-	-	-	-	Cabinet	Feature	RGB	7-LP-62	511-1135-00
283	Speaker 22-R	7	-	CN1	-	-	-	-	Cabinet	Feature	RGB	7-LP-64	511-1135-00
284	Speaker 22-G	7	-	CN1	-	-	-	-	Cabinet	Feature	RGB	7-LP-63	511-1135-00
285	Speaker 22-B	7	-	CN1	-	-	-	-	Cabinet	Feature	RGB	7-LP-65	511-1135-00
286	Speaker 23-R	7	-	CN1	-	-	-	-	Cabinet	Feature	RGB	7-LP-67	511-1135-00
287	Speaker 23-G	7	-	CN1	-	-	-	-	Cabinet	Feature	RGB	7-LP-66	511-1135-00
288	Speaker 23-B	7	-	CN1	-	-	-	-	Cabinet	Feature	RGB	7-LP-68	511-1135-00
289													
290													

Continued on next page...



LIGHT REFERENCE CONTINUED

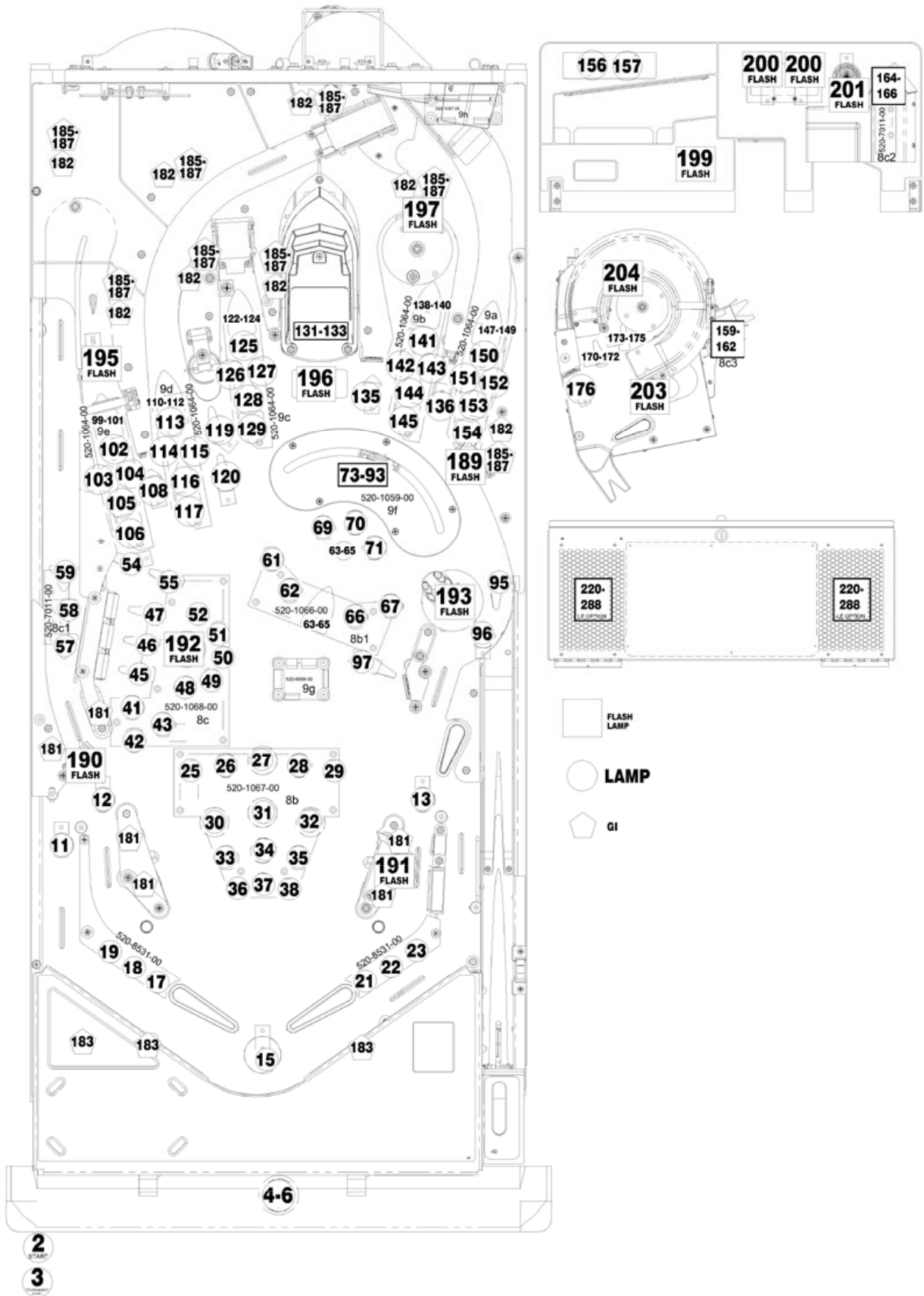

Figure 3.4.1. Playfield light locations (top view).



### 3.5 MOTOR REFERENCE

ID	Name	Node	Node Ext.	Conn.	Ret. Pin	Ret. Wire	Src. Pin	Src. Wire	Location	Type	Light Color	Address	Part Number
1	Motor A Enable	9	g	CN1	-	-	-	-	Playfield	Motor-511-3111-00 041-5161-00	-	9-LP-72	520-6996-00
2	Motor A Control 1A	9	g	CN1	-	-	-	-	Playfield	Motor-511-3111-00 041-5161-00	-	9-LP-73	520-6996-00
3	Motor A Control 2A	9	g	CN1	-	-	-	-	Playfield	Motor-511-3111-00 041-5161-00	-	9-LP-74	520-6996-00
4													
5													

Bi-Direction						
MOTOR A		Coast	Brake	Brake	Dir. 1	Dir. 2
x-LP-0	Enable A	H	L	L	L	L
x-LP-1	Control 1A	H	L	H	L	H-PWM
x-LP-2	Control 2A	H	L	H	H-PWM	L
MOTOR B		Coast	Brake	Brake	Dir. 1	Dir. 2
x-LP-3	Enable B	H	L	L	L	L
x-LP-4	Control 1B	H	L	H	L	H-PWM
x-LP-5	Control 2B	H	L	H	H-PWM	L
x=Node #			L/Low=Lamp On H/High=Lamp Off			
	Motor Wiring: Drive 1A&2A/1B&2B					
Single Direction						
MOTORS 1 & 2		Coast	Brake	Motor 1	Motor 2	
x-LP-0	Enable A	H	L	L	L	
x-LP-1	Control 1A	H	L	H-PWM	N/A	
x-LP-2	Control 2A	H	L	N/A	H-PWM	
MOTORS 3 & 4		Coast	Brake	Motor 3	Motor 4	
x-LP-3	Enable B	H	L	L	L	
x-LP-4	Control 1B	H	L	H-PWM	N/A	
x-LP-5	Control 2B	H	L	N/A	H-PWM	
x=Node #			L/Low=Lamp On H/High=Lamp Off			
Single Direction Notes:					PWM Notes:	
	When Enable A is High both motors (1&2) are off (coast)				12V Motor - PWM of 25%	
	When Enable B is High both motors (3&4) are off (coast)				24V Motor - PWM of 50%	
	Motor Wiring: 48V & re- quired drive					

Continued on next page...



## 4. ELECTRONIC PINOUTS AND SCHEMATICS

### 4.1 SPIKE-2 CPU NODE 0

#### 509-1003-01

#### DIRECT SWITCH MAPPING (CN25)

The coin-door diagnostic switches are connected directly to the CPU node via the Cabinet Node. Note that both the CPU and Cabinet nodes are required for diagnostic switch operation.

ID	Name	Conn.	Input Pin	Input Wire	GND Pin	Ground Wire	Location	Type	Address	Part Number
C1	DIP 1	-	-	-	-	-	CPU Node		0-SW-0	-
C2	DIP 2	-	-	-	-	-	CPU Node		0-SW-1	-
C3	DIP 3	-	-	-	-	-	CPU Node		0-SW-2	-
C4	DIP 4	-	-	-	-	-	CPU Node		0-SW-3	-
C5	DIP 5	-	-	-	-	-	CPU Node		0-SW-4	-
C6	DIP 6	-	-	-	-	-	CPU Node		0-SW-5	-
C7	DIP 7	-	-	-	-	-	CPU Node		0-SW-6	-
C8	DIP 8	-	-	-	-	-	CPU Node		0-SW-7	-
C9	Service Select	CN25	1	LGN-GRY	11	BLK-WHT	Coin Door		0-SW-9	180-5192-04
C10	Service Plus	CN25	2	LGN-VIO	11	BLK-WHT	Coin Door		0-SW-10	180-5192-02
C11	Service Minus	CN25	3	LGN-BLU	11	BLK-WHT	Coin Door		0-SW-11	180-5192-02
C12	Service Back	CN25	4	LGN-BLK	11	BLK-WHT	Coin Door		0-SW-12	180-5192-00

### CONNECTORS

ID	Connector Type	Description
CN1	5-Pin .156" Header	Backbox 2-channel amplified speaker out
CN2	3-Pin .100" Header	Console Port
CN3	7-Pin .100" Header	Headphone connector
CN4	2-Pin .156"	Cabinet 1-channel amplified speaker out
CN5	7-Pin .100" Header	Line In/Out
CN6	34 Pin 2.00mm Header	LCD display connector
CN7	5-Pin .156" Header	48V supply from main power supply
CN8	6-Pin .100" Header	SPI Serial
CN9	USB	USB connector - for software updates, audit dumps, and expansion modules
CN9	USB	USB connector - for software updates, audit dumps, and expansion modules
CN10	HDMI	HDMI Out
CN11	RJ45	SPIKE node bus - to cabinet node N1
CN12	RJ45	SPIKE node bus - To Topper accessory Kit
CN13	SD CARD	SD Card connector
CN14	5-Pin .100" Header	LCD Backlight
CN15	3-Pin .100" Header	Backbox Light
CN16	4-Pin .100" Header	3.3v / 5v / 12v
CN17	ETHERNET	ETHERNET connector
CN21	SATA Header	SATA connector
CN22	RJ45	SPIKE node bus - to playfield node
CN25	12-Pin .100" Header	Dedicated switch inputs - service, volume switches

### COMPONENTS

ID	Name
S1	DIP Switches
S2	Reset Switch
SD CARD (CN13)	For system SD card. Note: only to be removed if instructed to by Stern Service.
BT1	BR1225 3V Lithium battery for game clock between power cycles

### STATUS LEDs

LED ID	Name	Color	Description
48V	+48V Supply In	Red	ON: Main system power is connected. OFF: No 48V system power. Check power supply connections, cables, and fuses.
3.3V	+3.3V Logic	Red	ON: Logic power supply is good. OFF: Logic power supply bad, call tech support.
5V	+5V Logic	Red	ON: Logic power supply is good. OFF: Logic power supply bad, call tech support.
12V	+12V Backbox Illumination	Red	ON: Back box LED power good. OFF: Backbox LED power bad, call tech support.
VA	+30V Audio	Red	ON: Audio power supply is good. OFF: Audio power supply off, call tech support.
VNB	+9V Node Bus	Red	Power for the Node bus. ON: Power for node bus good. OFF: Power to node bus not detected, call tech support.
5V (CPU)	+5V Logic	Red	ON: Logic power supply is good. OFF: Logic power supply bad, call tech support.
SDIO ACT	Not Used	Red	Should remain unlit as it is not currently used.
STATUS	CPU Heartbeat, System Status	Red	Double blink ~ 1/2 second: Good, Processor running. OFF: Processor not running, call tech support.
µSD ACT	Activity indicator for micro SD Card	Red	Should blink rapidly when reading or writing to micro SD card.
D23	Netbridge Status	Red	Should blink once every ~1/2 second.

# SPIKE-2 CPU NODE 0 CONTINUED

## AUDIO PINOUTS

ID	Type	Pin	Description	Minimum Impedance	Max Power (RMS)	Wire Color
CN1	.156" 5-pin Header	1	Speaker Right Ground (-)	4 Ohms	-	BLK-WHT
		2	Speaker Right (+)	4 Ohms	20W	RED-WHT
		3	n/c	-	-	
		4	Speaker Left Ground (-)	4 Ohms	-	BLK-RED
		5	Speaker Left (+)	4 Ohms	20W	RED-BLK
CN3	.100" 7-pin Header	1	n/c	-	-	
		2	L-HP	16 Ohms	15 mW	
		3	R-HP	16 Ohms	15 mW	
		4	n/c	-	-	
		5	Headphone Detect	-	-	
		6	Headphone vol +	-	-	
		7	Headphone vol -	-	-	
CN4	.156" 2-pin Header	1	Woofer Ground (-)	8 Ohms	-	YEL-BLK
		2	Woofer Out (+)	8 Ohms	40W	YEL-WHT
CN5	.100" 7-pin Header	1	n/c	-	-	
		2	L-IN	30K Ohms	0.6VRMS	
		3	R-IN	30K Ohms	0.6VRMS	
		4	n/c	-	-	
		5	L-OUT	10K Ohms	1.5V	
		6	R-OUT	10K Ohms	1.5V	
		7	Woofer Line Out	10K Ohms	1.5V	

## COUNTRY CODES (DIP S2)

Country	DIP S2							
	1	2	3	4	5	6	7	8
USA	OFF	OFF	OFF	OFF	OFF	OFF	OFF	OFF
Austria	ON	OFF	OFF	OFF	OFF	OFF	OFF	OFF
Australia	ON	OFF	ON	ON	OFF	OFF	OFF	OFF
Belgium	OFF	ON	OFF	OFF	OFF	OFF	OFF	OFF
Canada 1	ON	ON	OFF	OFF	OFF	OFF	OFF	OFF
Canada 2	OFF	ON	OFF	ON	ON	OFF	OFF	OFF
China	OFF	OFF	ON	ON	ON	OFF	OFF	OFF
Croatia	OFF	ON	ON	OFF	ON	OFF	OFF	OFF
Denmark	ON	OFF	OFF	ON	OFF	OFF	OFF	OFF
Finland	ON	OFF	ON	OFF	OFF	OFF	OFF	OFF
France	OFF	ON	ON	OFF	OFF	OFF	OFF	OFF
Germany	ON	ON	ON	OFF	OFF	OFF	OFF	OFF
Greece	ON	ON	ON	ON	OFF	OFF	OFF	OFF
Italy	OFF	OFF	OFF	ON	OFF	OFF	OFF	OFF
Japan	ON	OFF	ON	OFF	ON	OFF	OFF	OFF
Middle East	ON	ON	ON	OFF	ON	OFF	OFF	OFF
Netherlands	OFF	OFF	ON	OFF	OFF	OFF	OFF	OFF
New Zealand	OFF	OFF	OFF	OFF	ON	OFF	OFF	OFF
Norway	OFF	ON	OFF	ON	OFF	OFF	OFF	OFF
Portugal	ON	OFF	OFF	OFF	OFF	OFF	OFF	OFF
Russia	ON	OFF	OFF	ON	ON	OFF	OFF	OFF
S. Africa	OFF	OFF	ON	OFF	ON	OFF	OFF	OFF
Spain	OFF	ON	OFF	OFF	ON	OFF	OFF	OFF
Sweden	ON	ON	OFF	ON	OFF	OFF	OFF	OFF
Switzerland	OFF	OFF	ON	ON	OFF	OFF	OFF	OFF
Taiwan	OFF	OFF	OFF	ON	ON	OFF	OFF	OFF
United Kingdom	OFF	ON	ON	ON	OFF	OFF	OFF	OFF

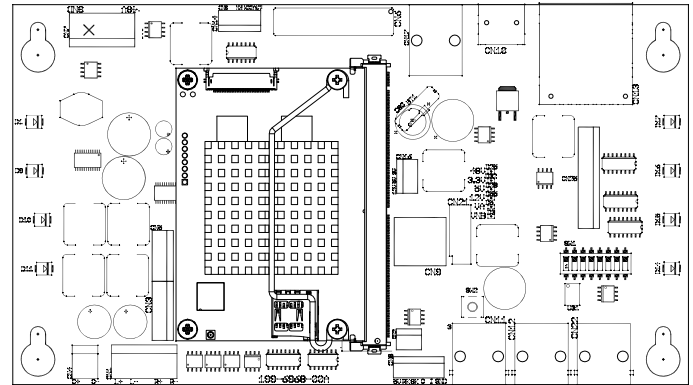

Figure 4.1.1. SPIKE 2 CPU Node connector detail.

## COIN DOOR SERVICE SWITCH WIRING

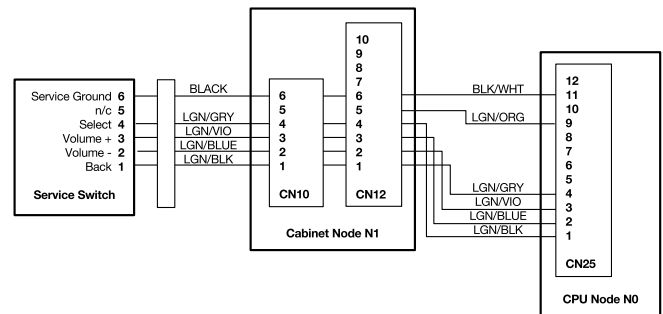

Figure 4.1.2. Service switch wiring. Note that the Cabinet Node must be present and CN10 and CN12 connected for the Coin Door Service Switches to function correctly.

# USA & INTERNATIONAL (NON-EURO) STANDARD PRICING SELECT TABLE

CPU/SOUND PCB DIP SWITCH SW1 SETTING		COUNTRY SETTING OPTION(S)	COIN MECHANISMS (SWITCHES)					PRICING SCHEME				Requires SPI Coin Card's Part Number					
Pos.	1 2 3 4 5 6 7 8		COINS THRU ... SLOT:					Number of Plays (Credits) for Price Amount Shown									
ON	▼		LEFT	CENTER	RIGHT	4TH	See "Appendix J" for Coin Cards Examples & Info!										
ON	▼	USA 1	0.25	1.00	0.25												
OFF	▼	USA 2								1/0.25	2/0.75	3/1.00	755-5400-01-Y				
	▼	USA 3								1/0.50	For USA 6 and USA 7 use: 755-5400-02-Y USA 6 Note: If player uses X4 25c quarters = 2 plays. However, \$1 bill = 3 plays!		755-5400-02-Y				
	▼	USA 4								1/0.50	3/1.50	5/2.00	755-5400-02-Y				
	▼	USA 5								1/0.50	2/1.00	3/1.50	755-5400-00-Y				
	▼	USA 6								1/0.50	2/1.00	3/\$ 1.00 Bill	Used to promote the Bill Validator.				
	▼	USA 7								1/0.50	2/1.00	4/1.50	6/2.00	755-5400-00-Y			
	▼	USA 8								1/0.50	3/1.00		755-5400-07-Y				
	▼	USA 9								1/1.00			755-5400-11-Y				
	▼	USA 10								1/0.75	2/1.50	3/2.00					
	▼	USA 11								1/1.00	3/2.00						
	▼	USA 12								1/0.25	2/0.50	3/0.75	5/1.00				
	▼	USA 13								1/1.00	2/2.00	3/3.00	4/4.00	7/5.00			
ON	▲	AUSTRALIA 1	0.20	1.00	2.00					1/1.00	3/2.00	755-5406-00-Y					
OFF	▼	AUSTRALIA 2								1/1.00			(1 Side)				
	▼	AUSTRALIA 3								1/2.00							
	▼	AUSTRALIA 4								1/2.00	2/4.00	3/5.00					
	▼	AUSTRALIA 5								1/3.00	2/5.00	3/8.00	5/10.00				
	▼	AUSTRALIA 6								1/2.00	2/3.00						
ON	▲	CANADA 1 [25c door]	0.25	0.25	1.00	2.00					755-5400-00-Y						
OFF	▼	CANADA 2 [dollar door]	1.00		2.00						-01-Y or -02-Y						
ON	▲	CANADA 2 [dollar door]	1.00		2.00						755-5400-10-Y						
ON	▲	CROATIA	1	2	5					1/3	2/5	755-5410-00-Y					
OFF	▼	CROATIA	1	2	5							(2-Sided)					
ON	▲	DENMARK 1	1	5	10	20					1/3	2/5	755-5402-00-Y				
OFF	▼	DENMARK 2	1	5	10	20					1/2	2/4	3/5	4/7	5/9	7/10	(2-Sided)
ON	▲	JAPAN 1	100		100					1/100		755-5408-01-Y					
OFF	▼	JAPAN 2	100		100					1/100	3/200	(2-Sided)					
ON	▲	MIDDLE EAST	token		token					1/1		755-5400-06-Y					
OFF	▼	MIDDLE EAST	token		token							(use Side 1)					
ON	▲	NEW ZEALAND 1	1		2					1/1		755-5406-00-Y					
OFF	▼	NEW ZEALAND 2	1		2					1/1	3/2	(Side 2)					
ON	▲	NORWAY 1	10	5	20					1/10		755-5403-01-Y or -02-Y / (2-Sided)					
OFF	▼	NORWAY 2	10	5	20					1/10	3/20	755-5403-03-Y					
	▼	NORWAY 3	10	5	20					1/20		(2-Sided)					
	▼	NORWAY 4	10	5	20					1/20	3/40						
	▼	NORWAY 5	10	5	20					1/10							
	▼	NORWAY 6	10	5	20					1/10	3/20						
	▼	NORWAY 7	10	5	20					1/20							
	▼	NORWAY 8	10	5	20					1/20	3/40						
ON	▲	RUSSIA	10	5	1					1/5		755-5411-00-Y					
OFF	▼	RUSSIA	10	5	1							(2-Sided)					
ON	▲	SO. AFRICA 1	0.50	1.00	1.00	1.00					1/2.00		755-5409-01-Y				
OFF	▼	SO. AFRICA 2	0.50	1.00	1.00	1.00					1/3.00	2/5.00	(2-Sided)				
ON	▲	SWEDEN 1	1	5	10					1/10	2/15	3/20	755-5404-00-Y				
OFF	▼	SWEDEN 2	1	5	10					1/5		(2-Sided)					
ON	▲	SWITZERLAND 1	1	2	5					1/1	2/2	3/3	4/4	6/5	755-5405-00-Y		
OFF	▼	SWITZERLAND 2	1	2	5					1/1	3/2	5/3	7/4	9/5	(2-Sided)		
ON	▲	TAIWAN	10		10					1/10		755-5412-00-Y					
OFF	▼	TAIWAN	10		10							(use Side 1)					
ON	▲	UK 1	0.10	0.50	1.00	0.20	2£					3/1.00	7/2.00	755-5407-00-Y			
OFF	▼	UK 2	0.10	0.50	1.00	0.20	2£					4/1.00		755-5407-01-Y*			
	▼	UK 3	0.10	0.50	1.00	0.20	2£					1/0.50	2/1.00	3/1.50	5/2.00	755-5407-01	
	▼	UK 4	0.10	0.50	1.00	0.20	2£					1/0.30	2/0.60	3/0.90	4/1.00	755-5407-01-Y*	
	▼	UK 5	0.10	0.50	1.00	0.20	2£					1/1.00	3/2.00		755-5407-01		
	▼	UK 6	0.10	0.50	1.00	0.20	2£					3/2.00		*use blank side	755-5407-01-Y*		

**HIGHLIGHTED** = Factory Default

**HIGHLIGHTED** = Not Shown on Coin Card



# EURO SUMMARY & INTERNATIONAL (EURO) STANDARD PRICING SELECT TABLE

CPU/SOUND PCB DIP SWITCH SW1 SETTING		COUNTRY SETTING OPTION(S)	COIN MECHANISMS (SWITCHES) COINS THRU ... SLOT:				PRICING SCHEME Number of Plays (Credits) for Price Amount Shown See "Appendix J" for Coin Cards Examples & Info!			Requires SPI Coin Card(s) Part Number												
Pos.	1	2	3	4	5	6	7	8	LEFT	CENTER	RIGHT	4TH	EUR // EUROPEAN UNION EUROS // [ € ]									
ON	S	E	E	B	E	L	O	W	0.50	1.00	2.00	0.20 <i>optional</i>	1/0.50			755-5401-01-Y						
OFF	S	E	T	T	I	N	G	S					1/0.50	2/1.00	3/1.50	5/2.00	755-5401-02-Y					
Euro 1-12 are alternate settings for countries using the Euro.		Euro 1	Euro 2	Euro 3	Euro 4	Euro 5	Euro 6	Euro 7					Euro 8	Euro 9	Euro 10	Euro 11	Euro 12	1/0.50	2/1.00	3/1.00	755-5401-03-Y	
<b>HIGHLIGHTED</b> = Factory Default																		1/0.50	2/1.00	3/1.50	6/2.00	755-5401-04-Y
<b>HIGHLIGHTED</b> = Not Shown on Coin Card																		1/0.50	3/1.00	4/1.50	7/2.00	755-5401-05-Y
																		2/0.50				755-5401-06-Y
																		1/1.00	2/2.00	3/3.00	5/4.00	755-5401-07-Y
																		1/1.00	3/2.00			755-5401-08-Y
																		1/1.00	2/1.50	3/2.00		755-5401-09-Y
																		1/1.00	3/2.00	7/3.00		755-5401-10-Y
																		1/1.00	4/2.00	6/3.00		755-5401-11-Y
																		2/1.00	4/2.00	6/3.00	9/4.00	755-5401-12-Y

For a different Euro Pricing Scheme (other than Factory Default listed below), scroll through Standard Adjustment 18: Euro 1-12 or CUSTOM\* for new setting (reference above Euro 1-12 Summary). Keep the Country Dip Switch Setting the same as listed below.

Pos.	1	2	3	4	5	6	7	8	Default Highlighted	EUR // EUROPEAN UNION EUROS // [ € ]						
ON	▲								AUSTRIA Euro 9	0.50	1.00	2.00	1/1.00	2/1.50	3/2.00	755-5401-09-Y
OFF	▼	▼	▼	▼	▼	▼	▼	▼					1/0.50			755-5401-01-Y
Pos.	1	2	3	4	5	6	7	8	Default Highlighted	EUR // EUROPEAN UNION EUROS // [ € ]						
ON	▲								BELGIUM Euro 1	0.50	1.00	2.00	1/0.50			755-5401-01-Y
OFF	▼	▼	▼	▼	▼	▼	▼	▼								
Pos.	1	2	3	4	5	6	7	8	Default Highlighted	EUR // EUROPEAN UNION EUROS // [ € ]						
ON	▲	▲							FINLAND Euro 8	0.50	1.00	2.00	1/1.00	3/2.00		755-5401-08-Y
OFF	▼	▼	▼	▼	▼	▼	▼	▼								
Pos.	1	2	3	4	5	6	7	8	Default Highlighted	EUR // EUROPEAN UNION EUROS // [ € ]						
ON	▲	▲							FRANCE Euro 10	0.50	1.00	2.00	1/1.00	3/2.00	7/3.00	755-5401-10-Y
OFF	▼	▼	▼	▼	▼	▼	▼	▼								
Pos.	1	2	3	4	5	6	7	8	Default Highlighted	EUR // EUROPEAN UNION EUROS // [ € ]						
ON	▲	▲	▲						GERMANY 1	0.50	1.00	2.00	1/0.50			755-5401-01-Y
OFF	▼	▼	▼	▼	▼	▼	▼	GERMANY 2	1/0.50				2/1.00	3/1.50	5/2.00	755-5401-02-Y
								GERMANY 3	1/0.50				2/1.00	3/1.50	6/2.00	755-5401-04-Y
Pos.	1	2	3	4	5	6	7	8	Default Highlighted	EUR // EUROPEAN UNION EUROS // [ € ]						
ON	▲	▲	▲	▲					GREECE Euro 8	0.50	1.00	2.00	1/1.00	3/2.00		755-5401-08-Y
OFF	▼	▼	▼	▼	▼	▼	▼	▼								
Pos.	1	2	3	4	5	6	7	8	Default Highlighted	EUR // EUROPEAN UNION EUROS // [ € ]						
ON				▲					ITALY 1	0.50		0.50	1/0.50			755-5401-01-Y
OFF	▼	▼	▼	▼	▼	▼	▼	▼	ITALY 2				1/1.00	3/2.00		755-5401-08-Y
Pos.	1	2	3	4	5	6	7	8	Default Highlighted	EUR // EUROPEAN UNION EUROS // [ € ]						
ON			▲						NETHERLANDS Euro 3	0.50	1.00	2.00	1/0.50	3/1.00		755-5401-03-Y
OFF	▼	▼	▼	▼	▼	▼	▼	▼								
Pos.	1	2	3	4	5	6	7	8	Default Highlighted	EUR // EUROPEAN UNION EUROS // [ € ]						
ON	▲			▲					PORTUGAL	0.50		0.50	1/0.50			755-5401-01-Y
OFF	▼	▼	▼	▼	▼	▼	▼	▼								
Pos.	1	2	3	4	5	6	7	8	Default Highlighted	EUR // EUROPEAN UNION EUROS // [ € ]						
ON	▲			▲					SPAIN Euro 8	0.50	1.00	2.00	1/1.00	3/2.00		755-5401-08-Y
OFF	▼	▼	▼	▼	▼	▼	▼	▼								

**HIGHLIGHTED** = Factory Default

**HIGHLIGHTED** = Not Shown on Coin Card



# 4.2 CABINET NODE 1

520-6967-72

ID	Type	Pin	Description	Wire Color
CN1	.100" 8-Pin Header Universal Card Link	1	12V	-
		2	Coin 1	-
		3	Meter 1	-
		4	N/C	-
		5	Notch	-
		6	Coin Enable	-
		7	Ticket Enable	-
		8	Ground	-
CN2	.100" 5-Pin Header Low Ticket	1	Ground	-
		2	Ticket Low sw.	-
		3	Key	-
		4	Ticket Low	-
		5	5V Out	-
CN3	.100" 3-Pin Header Meter 1	1	Meter 12V (+)	RED
		2	Meter (-)	BLK
		3	N/C	-
CN4	.100" 3-Pin Header Meter 2	1	Meter 12V (+)	RED
		2	Meter (-)	BLK
		3	N/C	-
CN5	.100" 9-Pin Header	1	5V Out	YEL/WHT
		2	Coin LED Out	YEL
		3	Ground	BLK
		4	Slam Tilt In	LGN/RED
		5	Coin 5	PNK/GRN*
		6	Coin 4	PNK/YEL*
		7	Coin 3	PNK/ORN*
		8	Coin 2	PNK/RED*
		9	Coin 1	PNK/BRN*
CN6	.100" 14-Pin Header Cabinet Left	1	5V LED Power	RED
		2	Start 2 LED	YEL-RED
		3	Start 1 LED	YEL-BRN
		4	Spare LED	-
		5	Ground	BLK-WHT
		6	Spare Left	-
		7	Tilt Input	WHT
		8	Door Open	-
		9	Start 2 Switch	GRY-WHT
		10	Start 1 Switch	GRY
		11	N/C	-
		12	N/C	-
		13	N/C	-
		14	N/C	-
CN7	.100" 12-Pin Header Cabinet Right	1	5V LED Power	RED
		2	Plunge 2 LED	RED-WHT
		3	Plunge 1 LED	GRN-WHT
		4	Spare LED 2	BLU-WHT
		5	Ground	BLK-WHT
		6	Spare Right In	-
		7	Plunge 2 Switch	-
		8	Plunge 1 Switch	-
		9	N/C	-
		10	N/C	-
		11	N/C	-
		12	N/C	-
CN8	.100" 10-Pin Header Dual Row Electronic Coin Mech	1	Ground	-
		2	12V	-
		3	Coin 5	-
		4	Coin 6	-
		5	N/C	-
		6	Coin Enable/Inhibit (+)	-
		7	Coin 1	-
		8	Coin 2	-
		9	Coin 3	-
		10	Coin 4	-

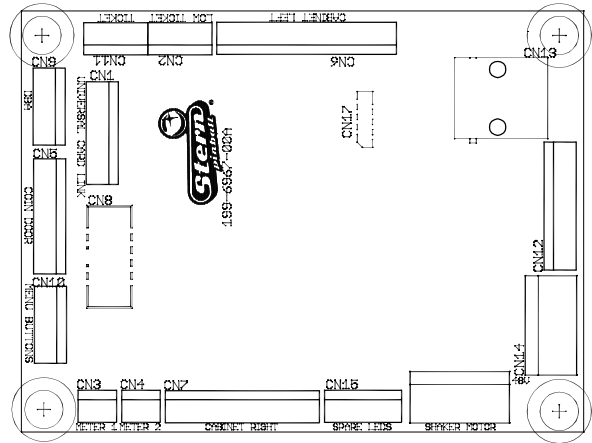

CN9	.100" 6-Pin Header Dollar Bill Acceptor	1	Coin Enable/DBA Inhibit (-)	BLK	
		2	Coin Enable/DBA Inhibit (+)	-	
		3	Key	Key	
		4	DBA 12V	ORG	
		5	Coin 6 / DBA Credit	-	
		6	Ground	BLK-ORG	
CN10	.100" 6-Pin Header Service Switch In	1	Service Back (To Coindoor)	LGN-BLK	
		2	Service Down (To Coindoor)	LGN-BLU	
		3	Service Up (To Coindoor)	LGN-VIO	
		4	Service Select (To Coindoor)	LGN-GRY	
		5	Key	Key	
		6	Service Ground (To Coin-door)	BLK	
CN11	.100" 5-Pin Header Ticket Dispenser	1	12V	RED	
		2	N/C	-	
		3	Ticket Dispenser Enable	WHT	
		4	Ground	BLK	
		5	Ticket Dispenser Notch	BLU	
CN12	.100" 10-Pin Header CPU Direct Switches	1	Service Back (To CPU)	LGN-BLK	
		2	Service Down (To CPU)	LGN-BLU	
		3	Service Up (To CPU)	LGN-VIO	
		4	Service Select (To CPU)	LGN-GRY	
		5	Power Present	LGN-ORG	
		6	Service Ground (To CPU)	BLK-WHT	
		7	N/C	-	
		8	N/C	-	
		9	N/C	-	
		10	N/C	-	
CN14	.156" 5-Pin Header Power Input	1	Ground	BLK	
		2	Key	Key	
		3	N/C	-	
		4	N/C	-	
		5	48VDC In	GRY-YEL	
CN15	.100" 6-Pin Header Spare LED's	1	5V LED Power	-	
		2	Key	Key	
		3	Spare LED 3	-	
		4	Spare LED 4	-	
		5	Spare LED 5	-	
		6	Spare LED 6	-	
CN16	.156" 5-Pin Header Shaker Motor	1	Shaker Motor (-)	BLU	
		2	Shaker Motor (-)	-	
		3	Shaker Motor (+)	-	
		4	Key	Key	
		5	Shaker Motor (+)	RED	
				*Varies by country model	



# 4.3 LOWER PLAYFIELD 48V DRIVER PINOUT NODE 8

520-7017-72 / 520-1057-00

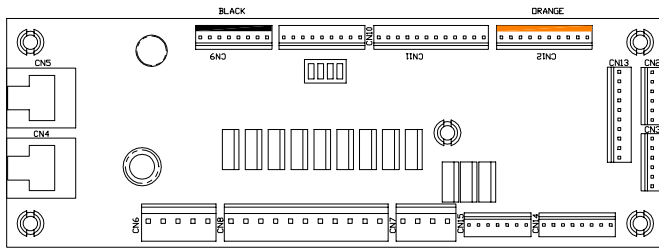

ID	Type	Pin	Description	Wire Color
SW1	Address DIP	-	Node 8 - OFF-OFF-OFF-OFF	-
CN4	RJ45	-	SPIKE Node Bus	Multi
CN5	RJ45	-	SPIKE Node Bus	Multi
CN6	.156" 5-Pin Header Node Power	1	Ground	BLK
		2	Key	Key
		3	N/C	-
		4	N/C	-
		5	48VDC In	GRY
CN7	.156" 4-Pin Header (White)	1	48V Driver Power	GRY-ORG
		2	8-DR-8 Driver Return	-
		3	8-DR-6 Driver Return	YEL-BLK
		4	8-DR-7 Driver Return	YEL-BRN
CN8	.156" 11-Pin Header (White)	1	48V Driver Power	GRY-ORG
		2	48V Driver Power	GRY-ORG
		3	48V Driver Power	GRY-ORG
		4	48V Driver Power	GRY-ORG
		5	8-DR-0 Driver Return	ORG-GRN
		6	8-DR-5 Driver Return	ORG-YEL
		7	8-DR-1 Driver Return	ORG-GRY
		8	8-DR-8 Driver Return	-
		9	8-DR-4 Driver Return	ORG-WHT
		10	8-DR-2 Driver Return	ORG-VIO
		11	8-DR-3 Driver Return	ORG-BLU
CN9	.100" 8-Pin Header (Black)	1	V+	-
		2	V+	-
		3	8-SW-24 Switch	GRY-RED
		4	8-SW-25 Switch	GRY-BRN
		5	8-SW-26 Switch	VIO-WHT
		6	8-SW-27 Switch	-
		7	Ground	BLK-GRN
		8	Ground	BLK-VIO
CN10	.100" 9-Pin Header	1	V+	-
		2	8-SW-28 Switch	GRY-WHT
		3	8-SW-29 Switch	GRY-VIO
		4	8-SW-30 Switch	GRY-BLU
		5	8-SW-31 Switch	GRY-GRN
		6	8-SW-16 Switch	GRY-YEL
		7	Ground	BLK-GRN
		8	Ground	BLK-GRN
		9	Ground	BLK-GRN

CN11	.100" 12-Pin Header	1	V+	-
		2	8-SW-26 Switch	-
		3	8-SW-27 Switch	-
		4	8-SW-17 Switch	-
		5	8-SW-18 Switch	-
		6	8-SW-19 Switch	-
		7	8-SW-20 Switch	-
		8	8-SW-21 Switch	-
		9	8-SW-22 Switch	-
		10	8-SW-23 Switch	-
		11	Ground	-
		12	Ground	-
CN12	.100" 10-Pin Header (Orange)	1	V+	-
		2	8-SW-8 Switch	WHT-BRN
		3	8-SW-9 Switch	WHT-RED
		4	8-SW-10 Switch	WHT-ORG
		5	8-SW-11 Switch	WHT-YEL
		6	8-SW-12 Switch	-
		7	8-SW-13 Switch	-
		8	8-SW-14 Switch	PNK-BLK
		9	8-SW-15 Switch	PNK-BRN
		10	Ground	BLK-RED
CN13	.100" 10-Pin Header	1	V+	-
		2	8-SW-0 Switch	-
		3	8-SW-1 Switch	-
		4	8-SW-2 Switch	-
		5	8-SW-3 Switch	-
		6	8-SW-4 Switch	-
		7	8-SW-5 Switch	-
		8	8-SW-6 Switch	-
		9	8-SW-7 Switch	-
		10	Ground	-
CN14	.100" 8-Pin Header	1	Ground	-
		2	8-LP-7 Driver Return	-
		3	8-LP-6 Driver Return	-
		4	8-LP-5 Driver Return	-
		5	8-LP-4 Driver Return	-
		6	8-LP-3 Driver Return	-
		7	LED V+	-
		8	LED V+	-
CN15	.100" 7-Pin Header	1	LED V+	YEL-BLK
		2	LED V+	YEL-RED
		3	LED V+	YEL-BLU
		4	-	-
		5	8-LP-0 GI Return	WHT-BLK
		6	8-LP-1 GI Return	RED-BLK
		7	8-LP-2 GI Return	BLU-BLK
CN2	.100" 6-Pin Header, Node Extension Bus	1	Ground	BLK
		2	DIN	VIO-BLK
		3	DOUT	VIO-BRN
		4	SCK	VIO-RED
		5	RCK	VIO-ORG
		6	V+	RED
CN3	.100" 6-Pin Header, Node Extension Bus	1	Ground	BLK
		2	DIN	VIO-BLK
		3	DOUT	VIO-BRN
		4	SCK	VIO-RED
		5	RCK	VIO-ORG
		6	V+	RED



# 4.4 UPPER PLAYFIELD 48V DRIVER PINOUT NODE 9

520-7017-72 / 520-1057-00

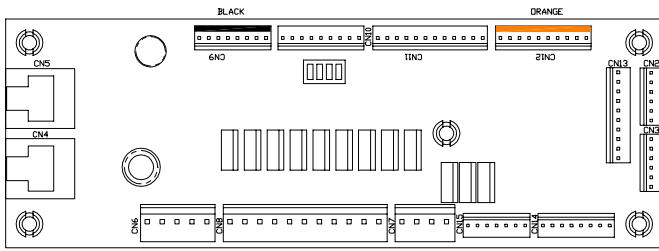

ID	Type	Pin	Description	Wire Color
SW1	Address DIP	-	Node 9 - OFF-OFF-ON-OFF	-
CN4	RJ45	-	SPIKE Node Bus	Multi
CN5	RJ45	-	SPIKE Node Bus	Multi
CN6	.156" 5-Pin Header Node Power	1	Ground	BLK
		2	Key	Key
		3	N/C	-
		4	N/C	-
		5	48VDC In	GRY
CN7	.156" 4-Pin Header (White)	1	48V Driver Power	GRY-BRN
		2	9-DR-8 Driver Return	-
		3	9-DR-6 Driver Return	YEL-GRN
		4	9-DR-7 Driver Return	YEL-BLU
CN8	.156 11-Pin Header (White)	1	48V Driver Power	GRY-BRN
		2	48V Driver Power	GRY-BRN
		3	48V Driver Power	GRY-BRN
		4	48V Driver Power	GRY-BRN
		5	9-DR-0 Driver Return	BRN-RED
		6	9-DR-5 Driver Return	YEL-VIO
		7	9-DR-1 Driver Return	YEL-GRY
		8	9-DR-8 Driver Return	-
		9	9-DR-4 Driver Return	-
		10	9-DR-2 Driver Return	-
		11	9-DR-3 Driver Return	ORG-BRN
CN9	.100" 8-Pin Header (Black)	1	V+	RED
		2	V+	-
		3	9-SW-24 Switch	TAN-BLK
		4	9-SW-25 Switch	TAN-VIO
		5	9-SW-26 Switch	TAN-WHT
		6	9-SW-27 Switch	-
		7	Ground	-
		8	Ground	BLK-BLU
CN10	.100" 9-Pin Header	1	V+	RED
		2	9-SW-28 Switch	GRY-BLK
		3	9-SW-29 Switch	GRY-BRN
		4	9-SW-30 Switch	GRY-RED
		5	9-SW-31 Switch	GRY-ORG
		6	9-SW-16 Switch	GRY-YEL
		7	Ground	BLK-BLU
		8	Ground	BLK-BLU
		9	Ground	BLK-BLU

CN11	.100" 12-Pin Header	1	V+	RED
		2	9-SW-26 Switch	-
		3	9-SW-27 Switch	-
		4	9-SW-17 Switch	LGN-RED
		5	9-SW-18 Switch	LGN-ORG
		6	9-SW-19 Switch	LGN-YEL
		7	9-SW-20 Switch	LGN-BLU
		8	9-SW-21 Switch	LGN-VIO
		9	9-SW-22 Switch	LGN-GRY
		10	9-SW-23 Switch	LGN-WHT
		11	Ground	BLK-ORG
		12	Ground	BLK-ORG
CN12	.100" 10-Pin Header (Orange)	1	V+	RED
		2	9-SW-8 Switch	WHT-BRN
		3	9-SW-9 Switch	WHT-RED
		4	9-SW-10 Switch	WHT-ORG
		5	9-SW-11 Switch	WHT-YEL
		6	9-SW-12 Switch	WHT-GRN
		7	9-SW-13 Switch	WHT-BLU
		8	9-SW-14 Switch	WHT-VIO
		9	9-SW-15 Switch	WHT-GRY
		10	Ground	BLK-WHT
CN13	.100" 10-Pin Header	1	V+	RED
		2	9-SW-0 Switch	PNK-RED
		3	9-SW-1 Switch	PNK-ORG
		4	9-SW-2 Switch	PNK-YEL
		5	9-SW-3 Switch	PNK-GRN
		6	9-SW-4 Switch	PNK-BLU
		7	9-SW-5 Switch	PNK-VIO
		8	9-SW-6 Switch	PNK-GRY
		9	9-SW-7 Switch	PNK-WHT
		10	Ground	BLK-BRN
CN14	.100" 8-Pin Header	1	Ground	BLK
		2	9-LP-7 Driver Return	-
		3	9-LP-6 Driver Return	-
		4	9-LP-5 Driver Return	YEL-GRY
		5	9-LP-4 Driver Return	YEL-VIO
		6	9-LP-3 Driver Return	YEL-BLU
		7	LED V+	-
		8	LED V+	YEL
CN15	.100" 7-Pin Header	1	LED V+	-
		2	LED V+	-
		3	LED V+	-
		4	-	-
		5	9-LP-0 GI Return	RED-BLK
		6	9-LP-1 GI Return	GRN-BLK
		7	9-LP-2 GI Return	BLU-BLK
CN2	.100" 6-Pin Header, Node Extension Bus	1	Ground	BLK
		2	DIN	VIO-BLK
		3	DOUT	VIO-BRN
		4	SCK	VIO-RED
		5	RCK	VIO-ORG
		6	V+	RED
CN3	.100" 6-Pin Header, Node Extension Bus	1	Ground	-
		2	DIN	-
		3	DOUT	-
		4	SCK	-
		5	RCK	-
		6	V+	-





# 4.5 CENTER LED BOARD 8B

520-1067-00

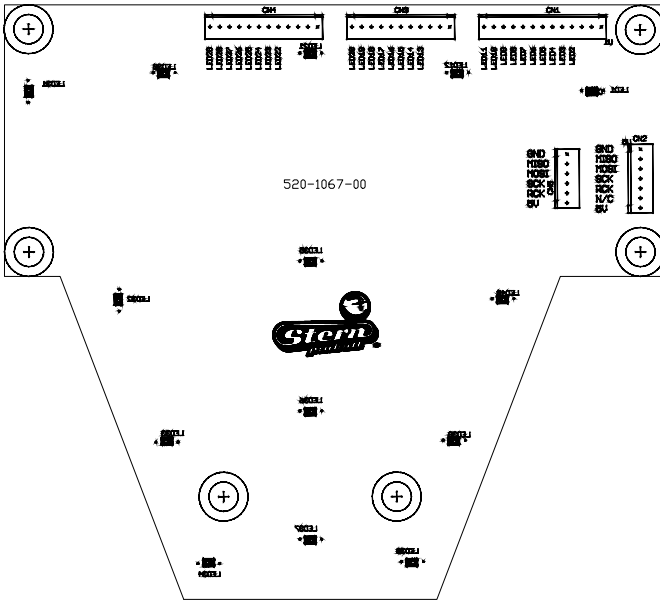

CN4	.100" 12-Pin Header	1	+5 VDC	RED
		2	+5 VDC	RED
		3	+5 VDC	-
		4	LED 22	BLU-BRN
		5	LED 23	BLU-RED
		6	LED 24	RED-GRY
		7	LED 25	GRN-GRY
		8	LED 26	BLU-GRY
		9	LED 27	BLU-ORG
		10	LED 28	BLU-GRN
		11	LED 29	BLU-VIO
		12	GND	-
CN5	.100" 6-Pin Header	1	Ground	BLK
		2	MISO Output Data	VIO-BLK
		3	MOSI Input Data	VIO-BRN
		4	SCK Serial Clock	VIO-RED
		5	RCK Register Clock	VIO-ORG
		6	V+	RED

ID	Type	Pin	Description	Wire Color
CN1	.100" 13-Pin Header	1	+5 VDC	RED
		2	+5 VDC	RED
		3	+5 VDC	-
		4	LED 2	BRN-RED
		5	LED 3	BRN-ORG
		6	LED 4	BRN-VIO
		7	LED 5	BRN-YEL
		8	LED 6	YEL-BRN
		9	LED 7	YEL-RED
		10	LED 8	YEL-ORG
		11	LED 9	YEL-GRN
		12	LED 10	YEL-BLU
		13	LED 11	YEL-VIO
CN2	.100" 7-Pin Header	1	Ground	BLK
		2	MISO Output Data	VIO-BLK
		3	MOSI Input Data	VIO-BRN
		4	SCK Serial Clock	VIO-RED
		5	RCK Register Clock	VIO-ORG
		6	NC	-
		7	+5 VDC IN	RED
CN3	.100" 11-Pin Header	1	+5 VDC	RED
		2	+5 VDC	RED
		3	+5 VDC	RED
		4	LED 13	ORG-BRN
		5	LED 14	ORG-RED
		6	LED 15	BRN
		7	LED 16	GRN-RED
		8	LED 17	GRN-ORG
		9	LED 18	GRN-YEL
		10	LED 19	GRN-BLU
		11	LED 20	GRN-VIO



### 4.6 LOWER MID RIGHT LED BOARD 8B1 520-1066-00

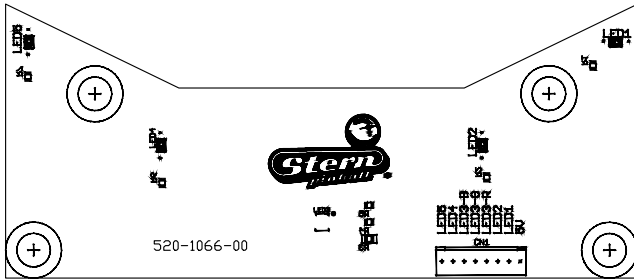

ID	Type	Pin	Description	Wire Color
CN1	.100" 8-Pin Header	1	+5 VDC	RED
		2	LED 1	BLU- BRN
		3	LED 2	BLU-RED
		4	LED 3-R	RED-GRY
		5	LED 3-G	GRN-GRY
		6	LED 3-B	BLU-GRY
		7	LED 4	BLU-ORG
		8	LED 5	BLU-GRN

### 4.8 3-LED BOARD 8C2 520-7011-00

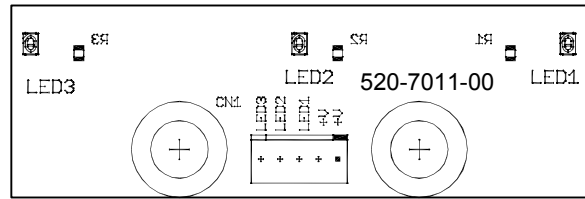

ID	Type	Pin	Description	Wire Color
CN1	.100" 5-Pin Header	1	5V	RED
		2	5V	-
		3	LP-1 Light Return	YEL-ORG
		4	LP-2 Light Return	YEL-GRN
		5	LP-3 Light Return	YEL-WHT

### 4.7 3-LED BOARD 8C1 520-7011-00

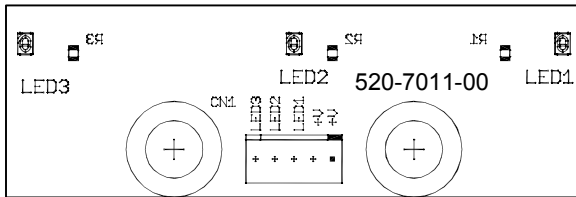

ID	Type	Pin	Description	Wire Color
CN1	.100" 5-Pin Header	1	5V	RED
		2	5V	-
		3	LP-1 Light Return	GRN-YEL
		4	LP-2 Light Return	GRN-ORG
		5	LP-3 Light Return	GRN-RED

### 4.9 BILLBOARD 4-LED BOARD 8C3 520-1076-00

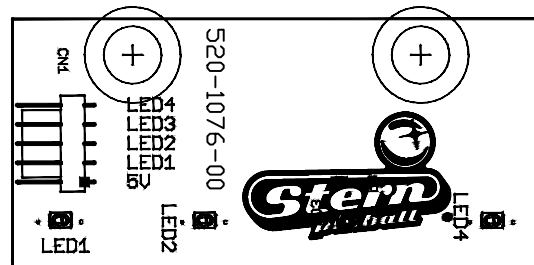

ID	Type	Pin	Description	Wire Color
CN1	.100" 5-Pin Header	1	5V	RED
		2	LED 1	BRN-WHT
		3	LED 2	BRN
		4	LED 3	BRN-VIO
		5	LED 4	BRN-BLU

# 4.10 LEFT LED BOARD 8C

520-1068-00

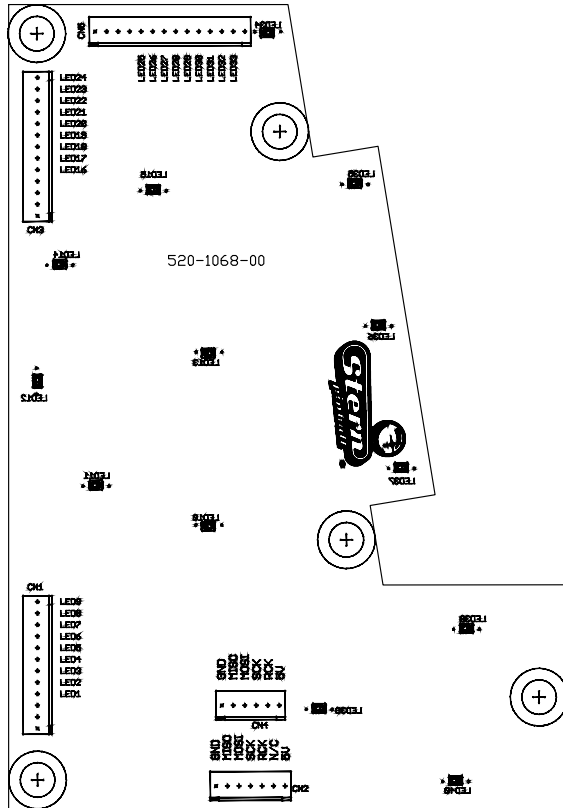

ID	Type	Pin	Description	Wire Color
CN1	.100" 12-Pin Header	1	+5 VDC	RED
		2	+5 VDC	RED
		3	+5 VDC	-
		4	LED 1	GRN-RED
		5	LED 2	GRN-ORG
		6	LED 3	GRN-YEL
		7	LED 4	GRN-BLU
		8	LED 5	GRN-VIO
		9	LED 6	GRN-GRY
		10	LED 7	ORG-BLU
		11	LED 8	ORG-VIO
		12	LED 9	ORG-WHT
CN2	.100" 7-Pin Header	1	Ground	BLK
		2	MISO Output Data	VIO-BLK
		3	MOSI Input Data	VIO-BRN
		4	SCK Serial Clock	VIO-RED
		5	RCK Register Clock	VIO-ORG
		6	NC	-
		7	+5 VDC IN	RED

CN3	.100" 13-Pin Header	1	+5 VDC	RED
		2	+5 VDC	RED
		3	+5 VDC	-
		4	+5 VDC	-
		5	LED 16	-
		6	LED 17	-
		7	LED 18	-
		8	LED 19	ORG-GRN
		9	LED 20	YEL-WHT
		10	LED 21	YEL-GRN
		11	LED 22	YEL-ORG
		12	LED 23	YEL-RED
		13	LED 24	YEL-BRN
CN4	.100" 6-Pin Header	1	Ground	-
		2	MISO Output Data	-
		3	MOSI Input Data	-
		4	SCK Serial Clock	-
		5	RCK Register Clock	-
		6	V+	-
CN5	.100" 14-Pin Header	1	+5 VDC	RED
		2	+5 VDC	-
		3	+5 VDC	-
		4	+5 VDC	-
		5	LED 25	ORG-BRN
		6	LED 26	ORG-RED
		7	LED 27	ORG-YEL
		8	LED 28	BRN-BLU
		9	LED 29	BRN-VIO
		10	LED 30	BRN
		11	LED 31	BRN-WHT
		12	LED 32	-
		13	LED 33	-
		14	GND	-

### 4.11 1-RGB 5-WHT LED BOARD 9A, 9B, 9C, 9D, 9E 520-1064-00

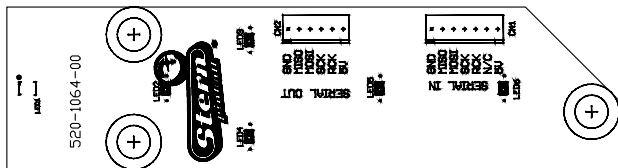

ID	Type	Pin	Description	Wire Color
CN1	.100" 7-Pin Header	1	Ground	BLK
		2	MISO Output Data	VIO-BLK
		3	MOSI Input Data	VIO-BRN
		4	SCK Serial Clock	VIO-RED
		5	RCK Register Clock	VIO-ORG
		6	NC	-
		7	+5 VDC IN	RED
CN2	.100" 6-Pin Header	1	Ground	BLK
		2	MISO Output Data	VIO-BLK
		3	MOSI Input Data	VIO-BRN
		4	SCK Serial Clock	VIO-RED
		5	RCK Register Clock	VIO-ORG
		6	V+	RED

### 4.12 SHARK FIN LED BOARD 9F 520-1059-00

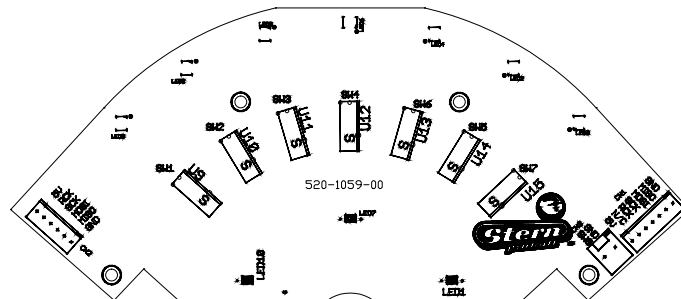

ID	Type	Pin	Description	Wire Color
CN1	.100" 7-Pin Header	1	Ground	BLK
		2	MISO Output Data	VIO-BLK
		3	MOSI Input Data	VIO-BRN
		4	SCK Serial Clock	VIO-RED
		5	RCK Register Clock	VIO-ORG
		6	NC	-
		7	+5 VDC IN	RED
CN2	.100" 6-Pin Header	1	Ground	BLK
		2	MISO Output Data	VIO-BLK
		3	MOSI Input Data	VIO-BRN
		4	SCK Serial Clock	VIO-RED
		5	RCK Register Clock	VIO-ORG
		6	V+	RED
CN3	.156" 2-Pin Header	1	GND	BLK
		2	SW8	ORG

### 4.13 SERIAL MOTOR DRIVER BOARD 9G BOARD 9G 520-6996-00

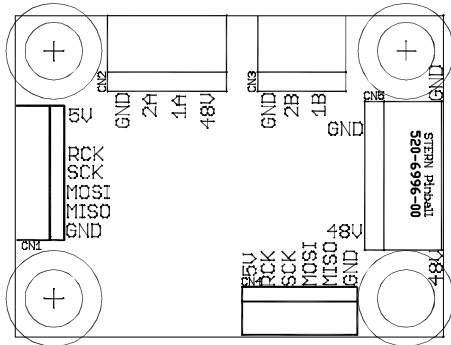

ID	Type	Pin	Description	Wire Color
CN1	.100" 7-Pin Header	1	Ground	BLK
		2	MISO Output Data	VIO-BLK
		3	MOSI Input Data	VIO-BRN
		4	SCK Serial Clock	VIO-RED
		5	RCK Register Clock	VIO-ORG
		6	n/c	-
		7	+5 VDC IN	RED
CN2	.156 4-Pin Connector	1	Ground	-
		2	DRIVE2-A	GRY
		3	DRIVE1-A	BRN
		4	V+	-
CN3	.156 3-Pin Connector	1	Ground	-
		2	DRIVE2-B	-
		3	DRIVE1-B	-
CN4	.100" 6-Pin Header	1	Ground	BLK
		2	MISO Output Data	VIO-BLK
		3	MOSI Input Data	VIO-BRN
		4	SCK Serial Clock	VIO-RED
		5	RCK Register Clock	VIO-ORG
		6	V+	RED
CN5	.156 5-Pin Connector	1	GND	BLK
		2	KEY	Key
		3	N/C	-
		4	N/C	-
		5	+48 VDC IN	GRY

### 4.14 SERIAL 16-LED BOARD 9H 520-1087-00

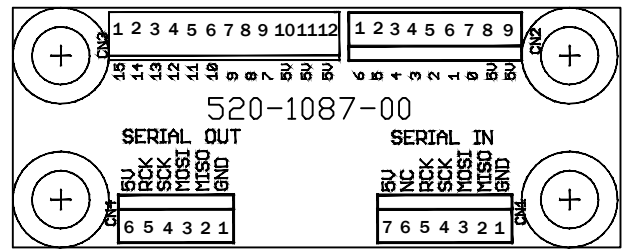

ID	Type	Pin	Description	Wire Color
CN1	.100 in 7-Pin Housing	1	Ground	BLK
		2	MISO Output Data	VIO-BLK
		3	MOSI Input Data	VIO-BRN
		4	SCK Serial Clock	VIO-RED
		5	RCK Register Clock	VIO-ORG
		6	n/c	-
		7	+5 VDC IN	RED
CN2	.100 in 9-Pin Housing	1	LED6	YEL-BRN
		2	LED5	BLU-BRN
		3	LED4	GRN-BRN
		4	LED3	RED-BRN
		5	LED2	BLU-ORG
		6	LED1	GRN-ORG
		7	LED0	RED-ORG
		8	+5 VDC LED Supply	RED
		9	+5 VDC LED Supply	-
CN3	.100 in 12-Pin Housing	1	LED15	-
		2	LED14	-
		3	LED13	-
		4	LED12	-
		5	LED11	-
		6	LED10	-
		7	LED9	-
		8	LED8	ORG-GRY
		9	LED7	ORG
		10	+5 VDC LED Supply	-
		11	+5 VDC LED Supply	-
		12	+5 VDC LED Supply	-
CN4	.100" 6-Pin Header	1	Ground	-
		2	DIN	-
		3	DOUT	-
		4	SCK	-
		5	RCK	-
		6	V+	-

### 4.15 TROUGH SERIAL OPTO RECEIVER 8A

520-8516-00

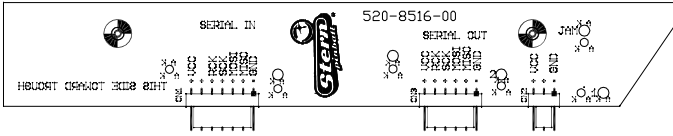

ID	Type	Pin	Description	Wire Color
CN1	.100" 7-Pin Header	1	Ground	BLK
		2	MISO Output Data	VIO-BLK
		3	MOSI Input Data	VIO-BRN
		4	SCK Serial Clock	VIO-RED
		5	RCK Register Clock	VIO-ORG
		6	N/C	-
		7	+5 VDC IN	RED
CN2	.100" 3-Pin Header	1	Ground	BLK
		2	N/C	-
		3	+5 VDC IN	RED
CN3	.100" 6-Pin Header	1	Ground	-
		2	MISO Output Data	-
		3	MOSI Input Data	-
		4	SCK Serial Clock	-
		5	RCK Register Clock	-
		6	V+	-

### 4.17 MAIN POWER SUPPLY

011-5003-00

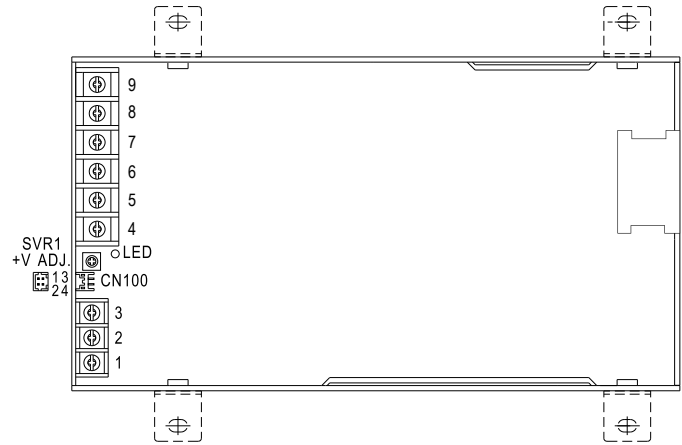

ID	Type	Pin	Description	Wire Color
CN1	Screw Terminal	1	AC Line Hot In	BLK
		2	AC Line Neutral In	WHT
		3	Earth Ground In	GRN
		4	DC Ground	BLK
		5	DC Ground	BLK
		6	DC Ground	BLK
		7	+48 V System Power	GRY
		8	+48 V System Power	GRY
		9	+48 V System Power	GRY

### 4.16 TROUGH SERIAL OPTO TRANSMITTER

520-5344-00

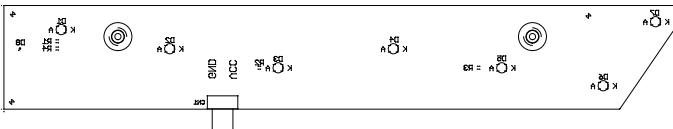

ID	Type	Pin	Description	Wire Color
CN1	.100" 3-Pin Header	1	Ground	BLK
		2	N/C	-
		3	+5 VDC IN	RED

# 4.18 POWER DISTRIBUTION BOARD

## 520-8096-00

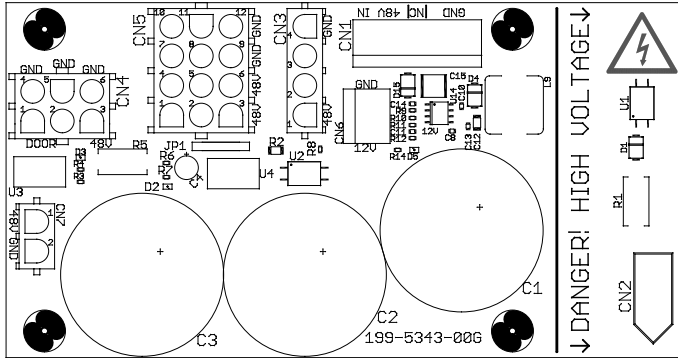

ID	Type	Pin	Description	Wire Color
CN1	.156 in 7-Pin Housing Plug: 045-5259-07 Pin: 055-5331-00 Key: 060-5013-00	1	+48 VDC IN	GRY
		2	+48 VDC IN	GRY
		3	+48 VDC IN	GRY
		4	Key (n/c)	-
		5	Ground	BLK
		6	Ground	BLK
		7	Ground	BLK
CN2	.093 in 3-Pos Plug Plug: 045-5003-03 Pin: 055-5013-09	1	Line In (100-240 VAC)	BLK
		2	Neutral	WHT
		3	Earth Ground	GRN
CN3	0.084 in 4-Pos Plug Plug: 045-5200-04 Pin: 055-5033-08	1	+48 VDC to CPU Node	GRY
		2	Door Interlock Switch Status	GRY/RED
		3	Line Voltage Status	VIO
		4	Ground	BLK
CN4	0.084 in 6-Pos Plug Plug: 045-5200-06 Pin: 055-5033-08	1	Door Interlock Switch +48V	GRY
		2	Door Interlock Switch +48V	-
		3	Switched 48V Out (to Node 1)	GRY/YEL
		4	Door Interlock Return Ground	GRY/RED
		5	Door Interlock Return Ground	-
		6	Ground (to Node 1)	BLK
CN5	0.084 in 12-Pos Plug Plug: 045-5200-12 Pin: 055-5033-08	1	Switched 48V Node Power	GRY
		2	Switched 48V Node Power	GRY
		3	Switched 48V Node Power	GRY
		4	Switched 48V Node Power	GRY
		5	Switched 48V Node Power	GRY
		6	Switched 48V Node Power	GRY
		7	Node Ground	BLK
		8	Node Ground	BLK
		9	Node Ground	BLK
		10	Node Ground	BLK
		11	Node Ground	BLK
		12	Node Ground	BLK
CN6	.156 in 3-Pos Plug: 045-5259-03 Pin: 055-5331-00 (18awg)	1	Ground	-
		2	Ground	-
		3	+12VDC	-
CN7	.084 2-Pos Plug: 045-5200-02 Pin: 055-5033-08	1	+48 VDC to Topper Node	GRY
		2	Ground	BLK

# 4.19 POWER PLUG WIRING

**CAUTION**

**TO MAINTAIN SAFETY, GROUND WIRE FROM LINE FILTER IS TO BE MOUNTED FIRST ON GROUNDING STUD AND SECURED WITH NUT. ALL OTHER GROUNDS MAY THEN BE ATTACHED TO GROUNDING STUD.**

**REPLACE ALL FUSES WITH CORRECT CURRENT RATINGS!**

## NORTH AMERICA

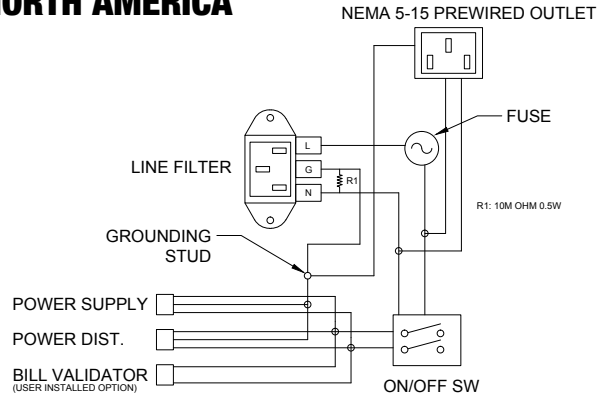

## INTERNATIONAL

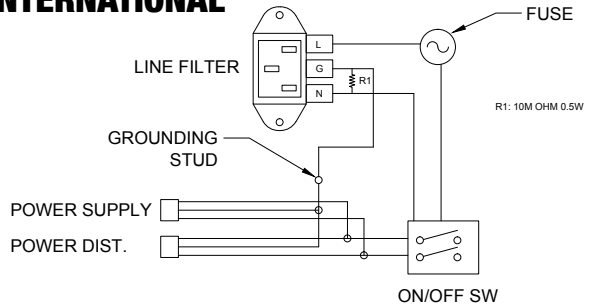

## LINE CORDS

Part Number	Description
034-6012-00	Line Cord, 3m, 5-15P USA
034-6012-01	Line Cord, 3m, CEE77P EUROPE
034-6012-02	Line Cord, 3m, BS1363P United Kingdom
034-6012-03	Line Cord, 3m, AS-NZS4417P Australia
034-6012-04	Line Cord, 3m, CEI23-16P Italy
034-6012-05	Line Cord, 3m, SEV1011P Switzerland
034-6012-06	Line Cord, 3m, JIS8303P Japan
034-6012-07	Line Cord, 3m, SI32P Israel
034-6012-08	Line Cord, 3m, BS546P S Africa, India
034-6012-09	Line Cord, 3m, IS6538P S. India

## LINE FUSES

Line Voltage (Region)	Fuse Current	Type	Part Number
120V (North America)	8 A	Slow Blow 30G	200-5000-05
220/240v (Europe, Australia, UK)	5 A	Slow Blow 5 x 20mm	200-5003-00



# 5. PARTS REFERENCE

## 5.1 PLAYFIELD RUBBER PARTS

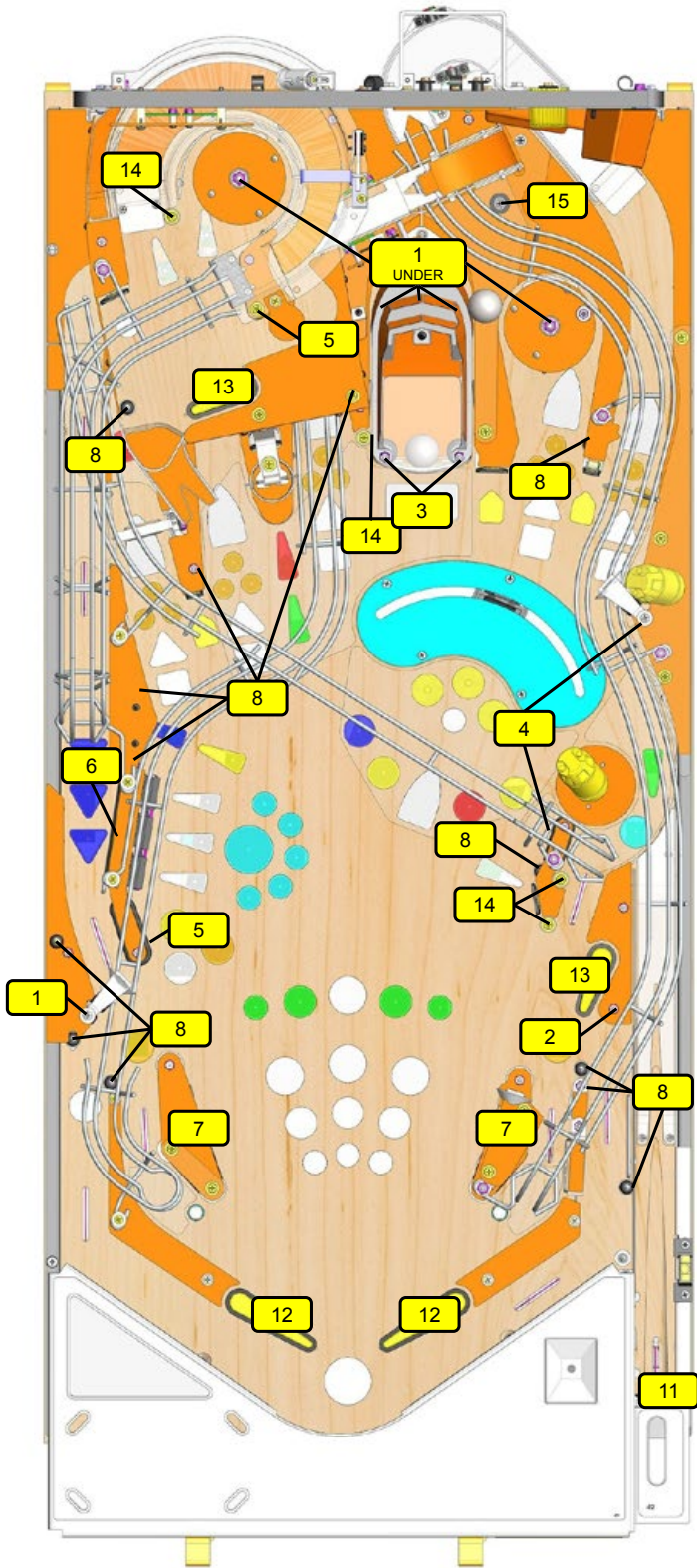

Figure 5.1.1. Rubber o-ring part locations

### RUBBER O-RINGS

ID	Qty	Size (ID)	Size (OD)	Durometer	Color	Part Number
1	6	3/16"		50	Black	545-5348-01
2	1	5/16"		50	Black	545-5348-02
3	4	3/8"		50	Black	545-5348-03
4	2	3/4"		50	Black	545-5348-04
5	2	1"		50	Black	545-5348-05
6	1	1-1/2"		50	Black	545-5348-07
7	2	2"		50	Black	545-5348-08
8	13		7/16"	50	Black	545-5348-17

Figure 5.2.2. Rubber o-ring part numbers and usage. ID: Inner Diameter, OD: Outer Diameter, Durometer: Higher number is firmer, less bounce, and more durable.

ID	Qty	Description	Color	Part Number
11	1	Plunger Tip	Black	545-5276-00
12	2	Flipper Rubber	Black	545-5277-00
13	2	Small Flipper Rubber	Black	545-5207-00
14	5	Post Sleeve	Black	545-5308-00
15	1	Post Rubber 1/2"	Black	545-5151-00
16	3	Bumper Pad (Sub assemblies)	Black	545-5105-00
17	4	Bumper Pad (Flippers)	Black	545-5428-00
18	8	Viton Rubber Rings (Sub Assemblies)	Brown	545-9991-01

Figure 5.2.3. Other rubber part numbers and usage

### 5.2 RUBBER SIZE CHART

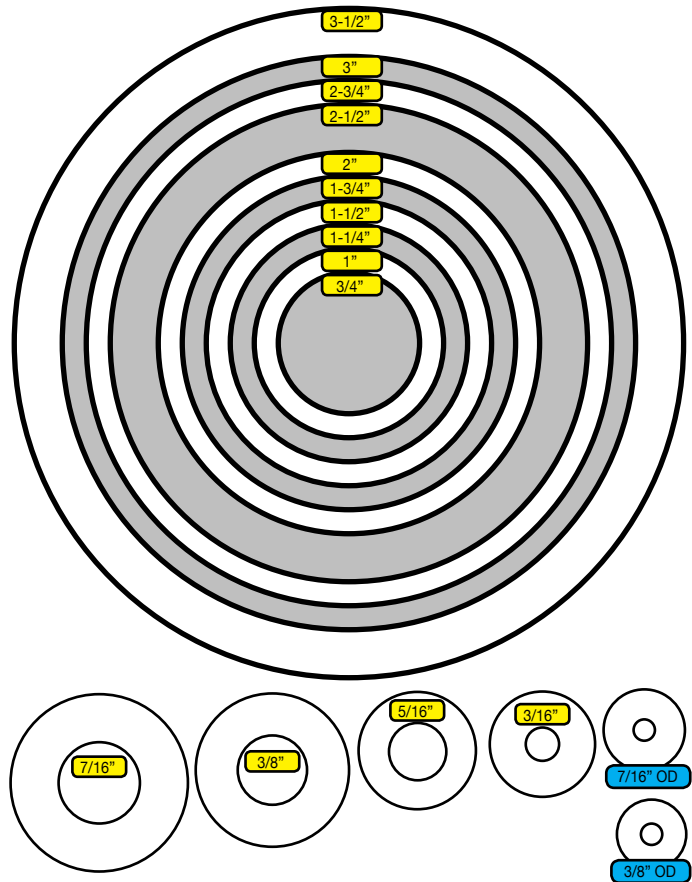

Figure 5.2.1. Rubber ring inner diameter sizing tool. Hold ring up to chart and read largest size on inside of ring. Dimensions are Inner Diameter (ID) unless otherwise noted as Outer Diameter (OD).



### 5.3 PLAYFIELD ASSEMBLIES, TOP



ID	Part Number	Description	Qty
1	500-2505-V6	Bottom Arch Assembly	1
2	755-51V6-XX	Instructions Card	1
3	755-7669-00	SPI Card	1
4	535-8385-00	Welded Hanger Bracket	1
5	509-2020-00	QR Reader	1
6	260-5000-00	Pinballs	7
7	500-6815-00	Bubble Level Assembly	1
8	535-2837-14	Shooter Lane Ramp	1
9	515-2806-00	Wire Ramp, Right	1
10	515-2803-00	Wire Ramp, Upper Left	1
11	515-2804-00	Wire Ramp, Upper Drain	1
12	515-2805-00	Wire Ramp, Center	1
13	511-8873-30	Boat Assembly	1
14	511-3073-01	Fishing Reel Spinner Top Assembly	1
	283-5019-00	3-Piece Thrust Bearing Set For 1/4" Shafts	1
15	511-3073-00	Ship Wheel Spinner Top Assembly	1
	283-5019-00	3-Piece Thrust Bearing Set For 1/4" Shafts	1
16	515-2801-00	Center Ramp (Attaches to Upper Playfield)	1
	232-5406-00P	Screw, #10-32 X 1" PPH SEMS, Patch	1
	242-5010-00	#10 Washer	1
17	511-4093-01	Top Mount Rollunder Gate Assembly	1
	234-5101-00	Screw, #8 X 1/2" SLT HWH AB Zinc	2
18	511-5401-00	Left Ramp Assembly	1
19	511-3097-98	Plastic Assembly -98	1
	520-1076-00	LED Board - 8c3	1
20	500-9936-01	Gate Assembly	1
21	511-3080-01	Shark Fin Filler Plate Assembly	1
22	500-1110-03-V6	3-Bank Drop Target Assembly	1
23	511-3044-00	Reflective Spinner Opto Assembly	1
24	511-4093-00	Harpoon Gate Assembly	1
25	511-4094-00	Chum Bucket Assembly	1
26	545-5409-01	Reflector	2
	535-1324-01	Retaining Clip	2
27	511-3097-03	Plastic Assembly -03	1
28	535-2288-00	Backpanel Handle	1
29	515-1935-00	Newton Ball	1

Figure 5.3.1. Major playfield assemblies, Top locations.

## 5.4 PLAYFIELD ASSEMBLIES, BOTTOM

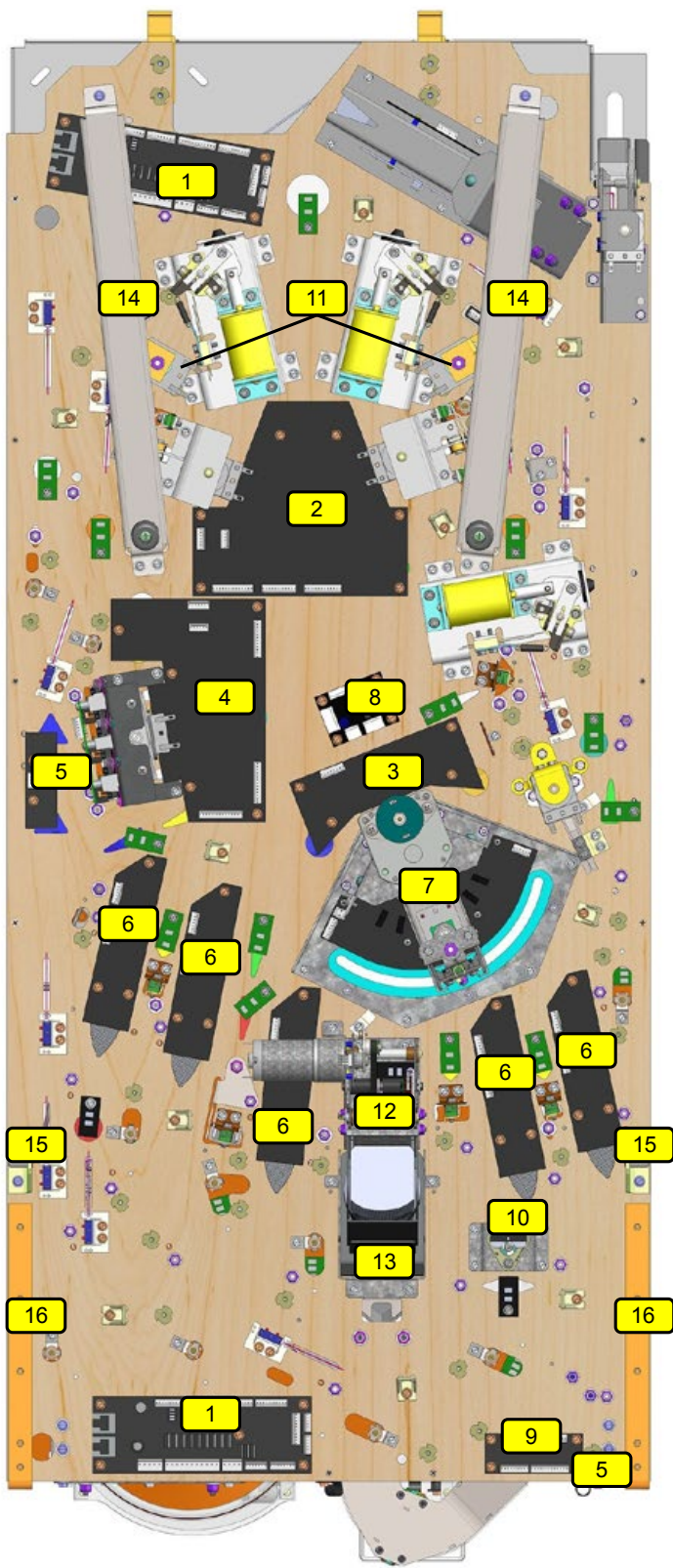

ID	Part Number	Description	Qty
1	520-1070-00	Core Node Driver Board	2
	520-1057-00		
2	520-1067-00	LED Board - 8b	1
3	520-1066-00	LED Board - 8b1	1
4	520-1068-00	LED Board - 8c	1
5	520-7011-00	LED Board - 8c1, 8c2	2
6	520-1064-00	LED Board - 9a, 9b, 9c, 9d, 9e	5
7	500-3636-00	Shark Fin Assembly (Includes 9f)	1
	234-5101-00	Screw, #8 X 1/2" SLT HWH AB Zinc	6
8	520-6996-00	Drive Board - 9g	1
9	520-1087-00	LED Board - 9h	1
10	511-3074-00	Lower Horizontal Spinner Assembly	2
	242-5008-00	Washer, 1/4" ID X 1/2" OD X 1/16" Thick	1
	270-5002-00	Retaining Ring, e-clip, 1/4" Diameter	1
11	500-7081-00	Ball Deflector Assembly	2
12	500-2679-00	Shark Assembly	1
13	535-2854-80	Shark Closeout Bracket	1
	234-5101-00	Screw, #8 X 1/2" SLT HWH AB Zinc	4
14	511-7621-00	Support Rail Assembly	2
15	500-5329-03	Pivot Bracket Assembly	2
16	535-5988-01	Edge Slide Bracket	2



Figure 5.4.1. Major playfield assemblies, Bottom locations.

## 5.5 BACKBOX PARTS

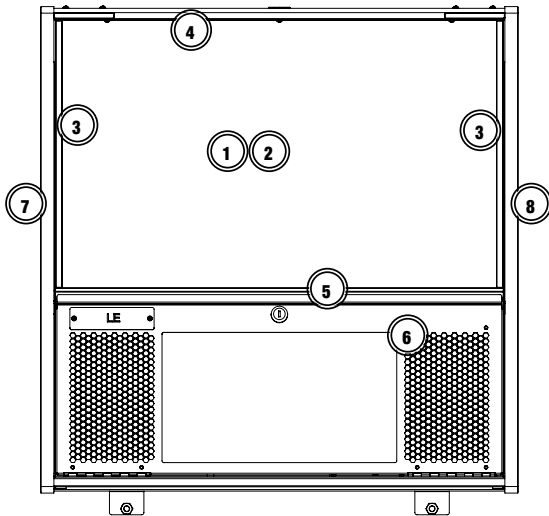

Figure 5.5.1. Backbox external assemblies and components

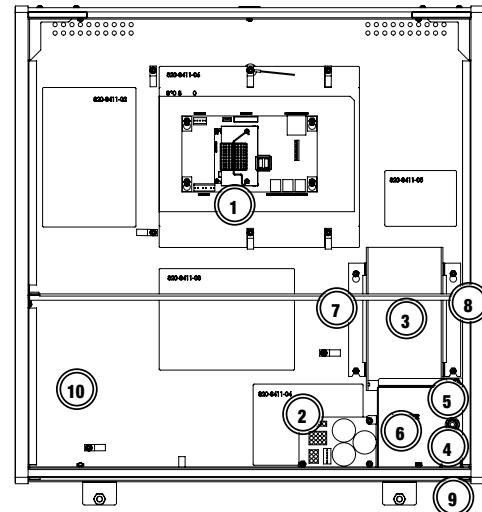

Figure 5.5.2. Backbox internal assemblies and components

### EXTERNAL

ID	Part Number	Description	Qty
1	660-5052-00	Backglass	1
2	830-8426-V6	Mirror Backglass [LE]	1
	830-8427-V7	Translite Art [Premium]	1
3	545-5018-17	Plastic Extrusion 15-.450"	2
4	545-5018-15	Glass Channel 26"	1
5	545-6313-01	Glass Lift Channel 26"	1
6	500-9996-00	LCD Speaker Panel Assembly	1
7	820-90V6-01	Left Backbox Decal [LE]	1
	820-76V7-01	Left Backbox Decal [Premium]	1
8	820-90V6-02	Right Backbox Decal [LE]	1
	820-76V7-02	Right Backbox Decal [Premium]	1
9	515-9866-00	Backbox Bottom Bracket [Not Labeled]	1

### INTERNAL

ID	Part Number	Description	Qty
1	509-1003-01	CPU Node Board	1
2	520-8096-00	Power Distribution Board	1
3	011-5003-00	Power Supply 48V/500W	1
4	515-9769-00	Utility Outlet (USA)	1
5	205-5001-00	Fuse Holder - Screw In	1
	200-5000-05	8A SB Fuse	1
6	535-1130-00	Cover AC	1
7	535-1129-00	Power Supply Bracket	1
8	535-1129-01	Power Supply Bracket	1
9	180-5001-03	Power Switch	1
10	520-5370-72	Speaker Lights Node Board [LE]	1

## 5.6 SPEAKER PANEL PARTS

500-9996-00

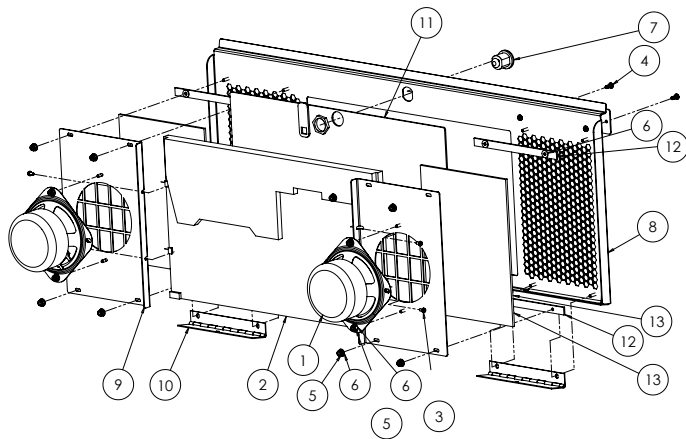

ID	Part Number	Description	Qty
1	545-9877-00	LCD WINDOW	1
2	240-5005-00	6-32 NYLON STOP NUT	16
3	242-5001-00	#6 WASHER	20
4	237-6188-01	SCREW, M3x0.5 X 6MM PPH SEMS ZINC	4
5	515-9845-00	HINGE, SPEAKER PANEL, LCD	2
6	515-9842-00	LCD SPEAKER BRACKET - BLACK MINI-TEX	1
7	515-1941-00	SPEAKER PLATE, 5.25" DRIVERS	2
8	545-9877-01	SPACER, SMALL - LCD SPEAKER PANEL	4
9	355-5168-00-00	LOCK ASSEMBLY, BLACK, 5/8"TL + 1.8"LG STRAIGHT CAM	1
10	040-5016-00B	CABLE CLAMP 0.38 BLACK	2
11	040-5002-00	MOUNTING PAD	1
12	031-5017-00	SPEAKER, PREMIUM AUDIO	2
13	626-5001-00	FOAM RUBBER, 3/8" W X 3/16" THK	1
14	546-7693-02	SPEAKER RING, JAWS LE	2
15	116-0023-00	1366 x 768 DISPLAY LCD PANEL	1
16	820-1098-00	DECAL, LIGHT BLOCKER, SPEAKER PANEL	4
17	511-1135-00	ASM, SPEAKER LIGHT RING	2

## 5.7 SPEAKER PANEL PARTS - LE

500-2442-V6

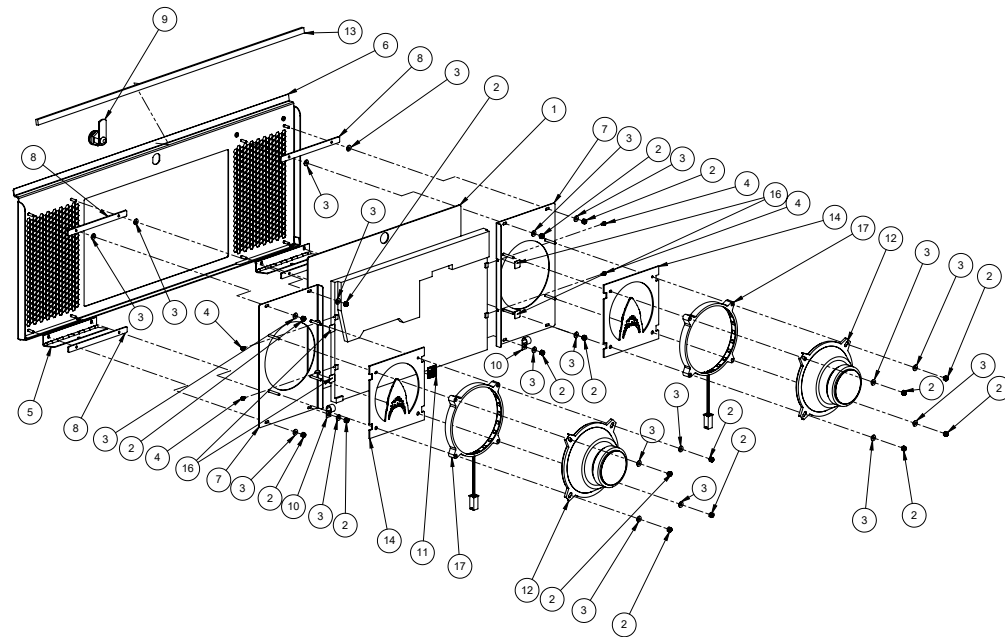

ID	Part Number	Description	Qty
1	545-9877-00	LCD WINDOW	1
2	240-5005-00	6-32 NYLON STOP NUT	16
3	242-5001-00	#6 WASHER	20
4	237-6188-01	SCREW, M3x0.5 X 6MM PPH SEMS ZINC	4
5	515-9845-00	HINGE, SPEAKER PANEL, LCD	2
6	515-9842-00	LCD SPEAKER BRACKET - BLACK MINI-TEX	1
7	515-1941-00	SPEAKER PLATE, 5.25" DRIVERS	2
8	545-9877-01	SPACER, SMALL - LCD SPEAKER PANEL	4

9	355-5168-00-00	LOCK ASSEMBLY, BLACK, 5/8"TL + 1.8"LG STRAIGHT CAM	1
10	040-5016-00B	CABLE CLAMP 0.38 BLACK	2
11	040-5002-00	MOUNTING PAD	1
12	031-5017-00	SPEAKER, PREMIUM AUDIO	2
13	626-5001-00	FOAM RUBBER, 3/8" W X 3/16" THK	1
14	546-7693-02	SPEAKER RING, JAWS LE	2
15	116-0023-00	1366 x 768 DISPLAY LCD PANEL	1
16	820-1098-00	DECAL, LIGHT BLOCKER, SPEAKER PANEL	4
17	511-1135-00	ASM, SPEAKER LIGHT RING	2

# 5.8 CABINET PARTS

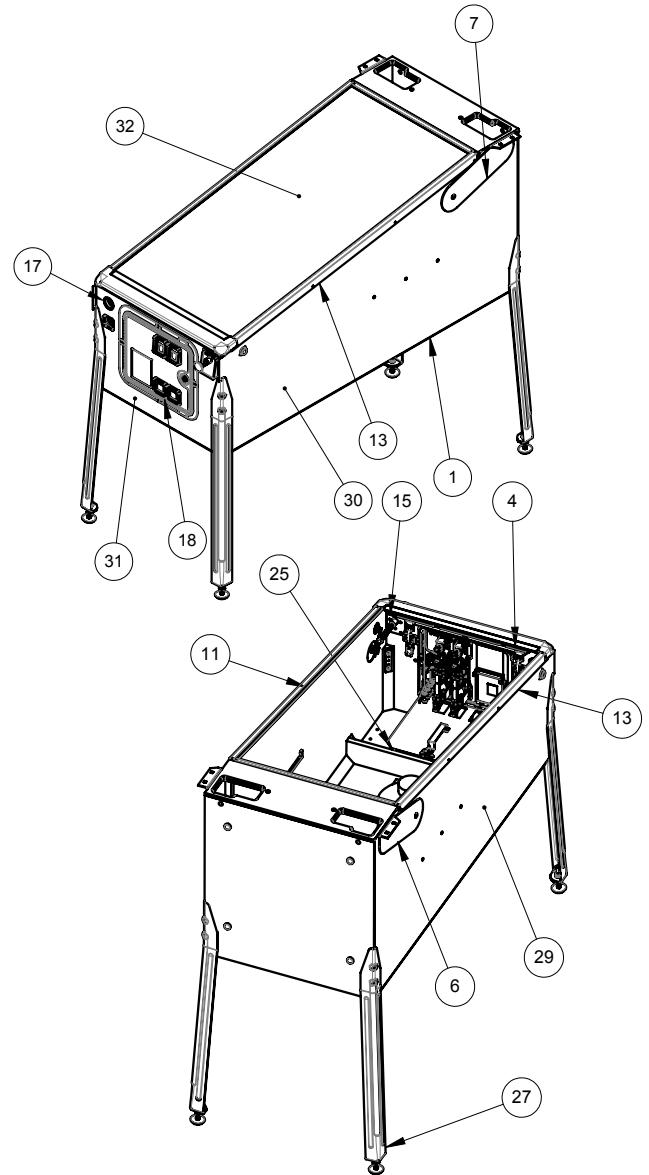
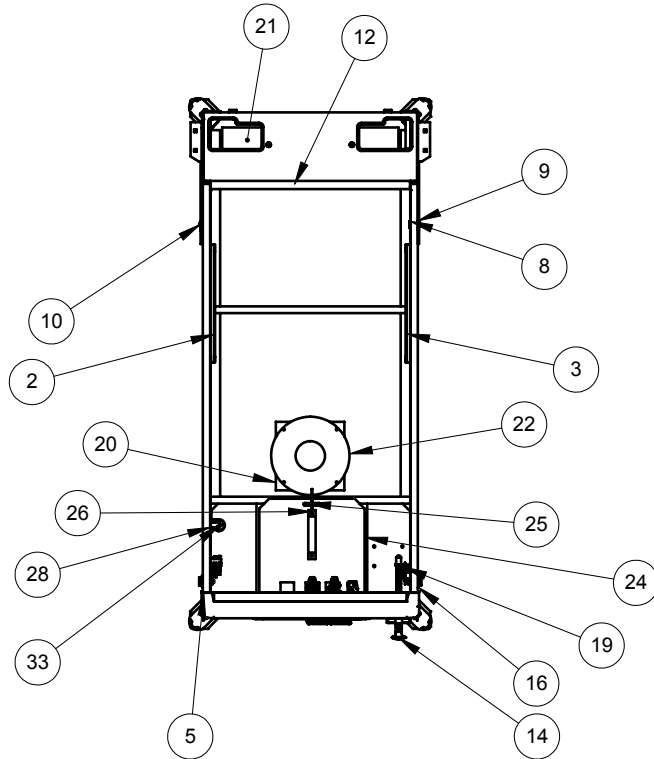

ID	Part Number	Description	Qty
1	525-6026-01	Cabinet Assembly, Single Button	1
2	535-5989-00	Slide & Pivot Bracket - Left Side	1
3	535-5990-00	Slide & Pivot Bracket - Right Side	1
4	535-2051-00	Cabinet Playfield Support Bracket	1
5	500-2440-88	Front Molding Assembly - Signal White [LE]	1
	500-2440-00	Front Molding Assembly - Wrinkle Black [Premium]	1
6	535-7999-88L	Pivot Hinge, Left - Signal White [LE]	1
	535-7999-00	Pivot Hinge, Left - Wrinkle Black [Premium]	1
7	535-7999-88R	Pivot Hinge, Right - Signal White [LE]	1
	535-7999-01	Pivot Hinge, Right - Wrinkle Black [Premium]	1
8	254-5042-00	Spacer Nut, Hex, 1/2"OD, 1/4-20	2
9	242-5084-00	Washer, 1/2" I.D., 3/16" THK	2
10	231-5072-00	1/4-20 X 1/2" Carriage Bolt	2
11	545-5017-00	Plastic Channel	2
12	545-5038-00	Glass Rear Extrusion	1
13	535-4088-00	Side Armor Left - Signal White [LE]	1
	535-4088-01	Side Armor Right - Signal White [LE]	1
	535-7297-02	Side Armor - Wrinkle Black [Premium]	2
14	500-2604-07	Ball Shooter Assembly - Orange Spring	1
15	535-5027-01	Plunger Support Plate, Notched	1
16	500-1169-32	Flipper Button Assembly (Red)	2
17	500-1060-44-LED	Start Button	1
18	501-5018-173	Coin Door 2-Chute No Emboss	1
19	180-5160-01	Flipper Switch, Single	2
20	545-5072-03	Grill - Speaker / Vent	1
21	545-5072-02	Grill - Speaker / Vent	1
22	031-5016-00	Woofer, 8" Round, 4Ω [LE]	1
	031-5007-01	Speaker, Cabinet 8" Round, 4 Ohm [Premium]	1
23	545-5090-00	Cash Box - Plastic	1
24	535-5013-03	Cash Box Cover	1

25	535-7562-00	Cash Box Lock Bracket Wire	1
26	535-7772-00	Hair Pin Clip	1
27	500-5921-88	Leg Assembly - Signal White [LE]	4
	500-5921-50	Leg Assembly - Wrinkle Black [Premium]	4
28	516-0007-00	Tilt Assembly	1
	535-5029-00	Tilt Plumb Bob	1
29	820-90V6-03	Decal, Cabinet Left, Jaws LE	1
	820-76V7-03	Decal, Cabinet Left, Jaws Premium	1
30	820-90V6-04	Decal, Cabinet Right, Jaws LE	1
	820-76V7-04	Decal, Cabinet Right, Jaws Premium	1
31	820-90V6-05	Decal, Cabinet Front, Jaws LE	1
	820-76V7-05	Decal, Cabinet Front, Jaws Premium	1
32	660-5053-00	High Resolution Glass [LE]	1
	660-5001-00	Playfield Glass [Premium]	1
33	520-6967-72	Cabinet Node Board	1
34	535-2049-00	Corner Brackets For Cabinet Legs	4
	234-5102-00	Screw, 8 X 5/8" SLT HWH AB Zinc	24
	820-90V6-XX	Cabinet Decal Replacement Set, Speaker Panel	
	820-76V7-XX	Decal Not Included	

## 5.9 BALL SHOOTER ASSEMBLY

500-2604-07

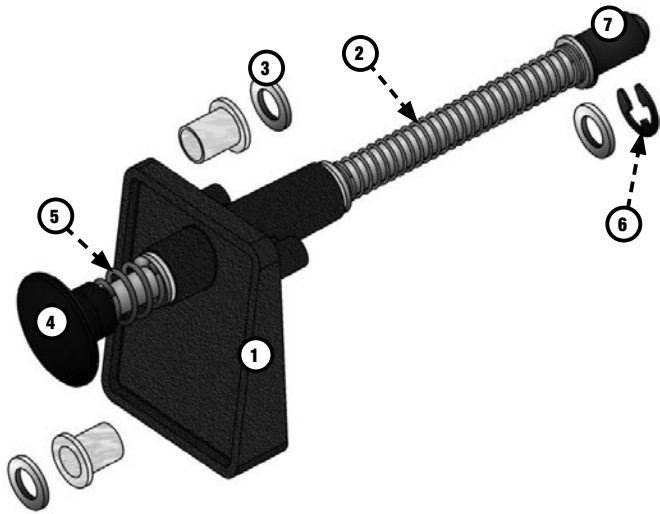

ID	Part Number	Description	Qty
1	535-5067-02	HOUSING ASSEMBLY	1
2	266-5001-07	COMPRESSED SPRING (LONG) - ORANGE	1
3	242-5014-00	WASHER 3/8 ID X 5/8 OD X 1/16"	3
4	515-6557-00	ROD ASSEMBLY	1
5	266-5010-00	COMPRESSED SPRING (SHORT)	1
6	270-5012-00	RETAINING RING, 3/8"	1
7	545-5276-00	RUBBER TIP	1

## 5.10 AUTO LAUNCH ASSEMBLY

500-9818-02

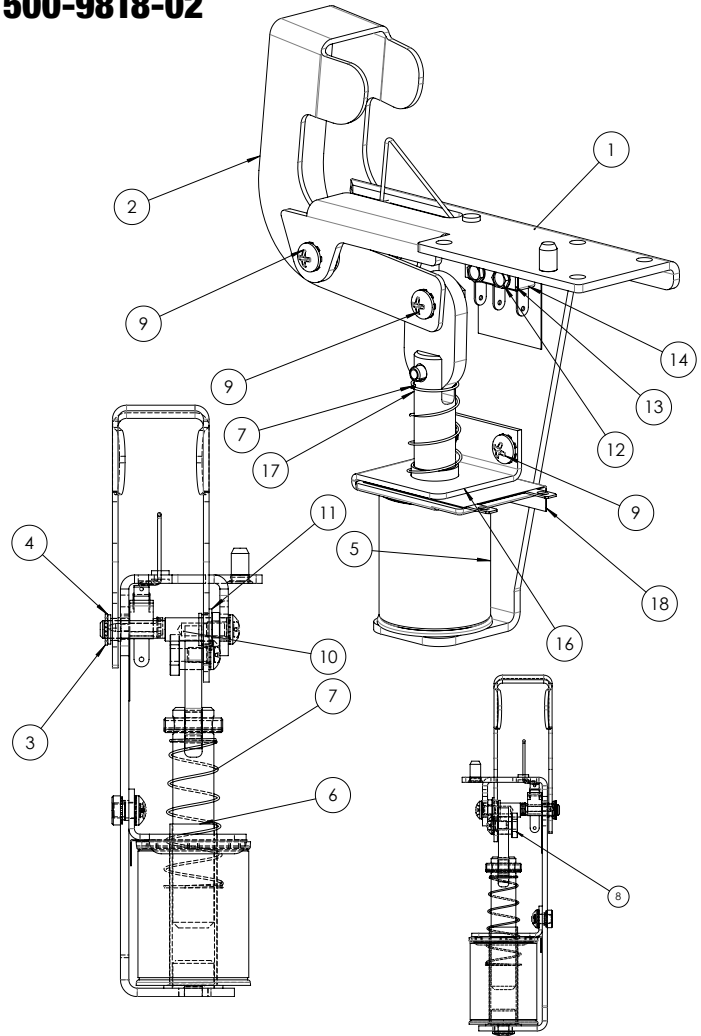

ID	Part Number	Description	Qty
1	515-9689-01	MAIN BRKT: AUTO-PLUNGER	1
2	535-0728-00	KICKER ARM, AUTO-PLUNGER	1
3	270-5001-00	RETAINING E-RING, 3/16" SHAFT OD	1
4	545-5352-00	NYLINER, 3/16" SHAFT	1
5	090-5001-ND	COIL - 23-800, NO DIODE	1
6	545-5411-00	COIL SLEEVE	1
7	266-5020-00	COMPRESSION SPRING-CONICAL	1
8	530-7834-00	PIN: KICKER ARM, AUTO-PLUNGER	1
9	232-5300-00	SCREW, 8-32 X 1/4" PPH SEMS	4
10	530-7835-00	PIVOT, AUTO-PLUNGER	1
11	545-5423-00	NYLINER, 1/4" SHAFT, 4L1-FF	1
12	237-5937-02	SCREW, 2-56 X 1/2" HWH MS	2
13	535-6539-00	SWITCH BODY PROTECT PLATE	1
14	180-5157-01	SHOOTER SWITCH - SHORT ARM	1
15	545-6268-00	FISCHE PAPER	1
16	535-0762-00	COIL BRACKET-AUTOPLUNGER	1
17	515-6304-03	PLUNGER / LINK ASSEMBLY	1
18	545-0762-00	FISCHE PAPER: AUTO-LAUNCHER	1

## 5.11 BALL TROUGH ASSEMBLY

500-9820-01

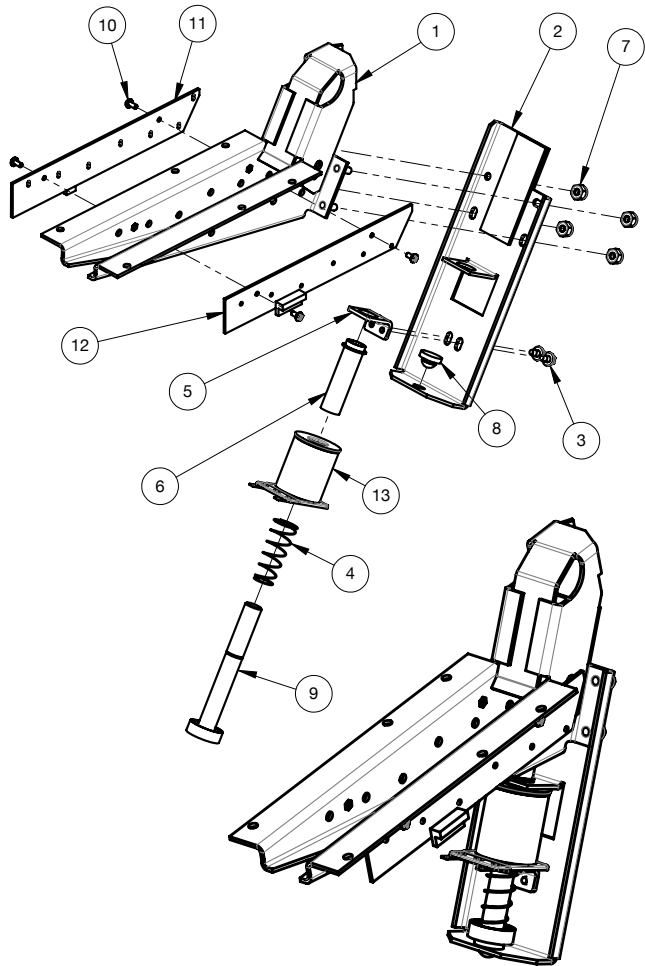

ID	Part Number	Description	Qty
1	515-7811-00	MAIN BRKT. BALL TROUGH	1
2	515-7812-00	COIL BRACKET, BALL TROUGH	1
3	237-5975-04	SCREW, 8-32 X 1/4" HWH SWAGE SERR	2
4	266-5020-00	COMPRESSION SPRING-CONICAL	1
5	535-5203-03	COIL RETAINING BRACKET	1
6	545-5076-01	COIL SLEEVE	1
7	240-5102-00	8-32 NYLON LOCK NUT	4
8	545-5105-00	RUBBER BUMPER	1
9	515-7309-01	PLUNGER ASSEMBLY	1
10	237-5909-00	SCREW, 4-40 X 1/4" PPH SEMS	4
11	520-5344-00	TROUGH BOARD #1 - ILED TRANSMITTER	1
12	520-8516-00	TROUGH BOARD #2 - RECEIVER	1
13	090-5004-ND	COIL 27-1500 - NO DIODE	1
98*	605-5006-00	SHRINK TUBING 1/8"	.42 FT.
99*	036-5611-11-F5	CABLE TROUGH OPTOS	1

## 5.12 SLINGSHOT ASSEMBLY

500-9920-01

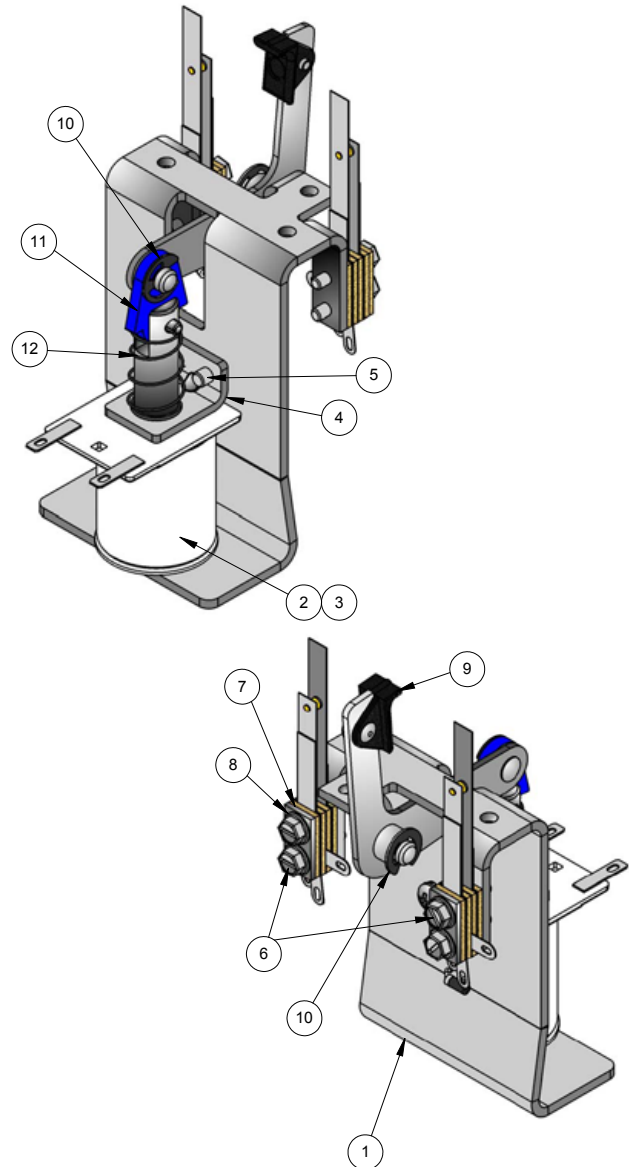

ID	Part Number	Description	Qty
1	515-5339-01	SLINGSHOT BRACKET ASSEMBLY	1
2	090-5044-ND	COIL 26-1200 - NO DIODE	1
3	545-5031-00	COIL SLEEVE	1
4	535-5203-03	COIL RETAINER BRACKET	1
5	232-5301-00	8-32 X 3/8 PPH MS EXT SEMS ZC	2
6	180-5231-00	SWITCH SLING SHOT 2 LUG CENTER	2
7	535-5045-00	SWITCH PLATE	2
8	237-5976-04	6-32 X 5/8 SLOT SER HWH SW	4
9	515-5340-01	ARM & TIP ASSEMBLY	1
10	270-5002-00	RETAINING RING - 1/4 DIA	2
11	515-5338-00	PLUNGER & LINK ASSEMBLY	1
12	266-5020-00	COMP SPRING CONICAL	1
13	036-5604-00	4" GENERIC JUMPER	2

## PARTS REFERENCE

### 5.13 FLIPPER ASSEMBLY, LEFT

500-6543-12-ND

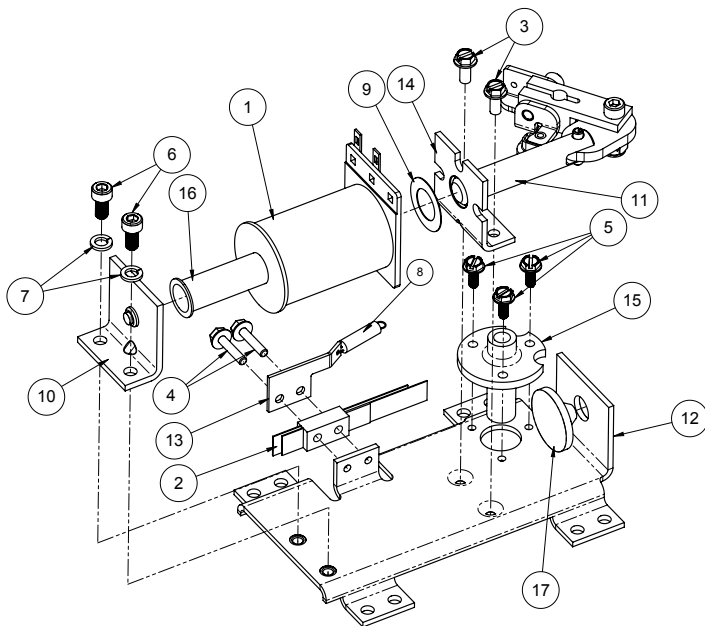

### 5.14 FLIPPER ASSEMBLY, RIGHT

500-6543-02-ND

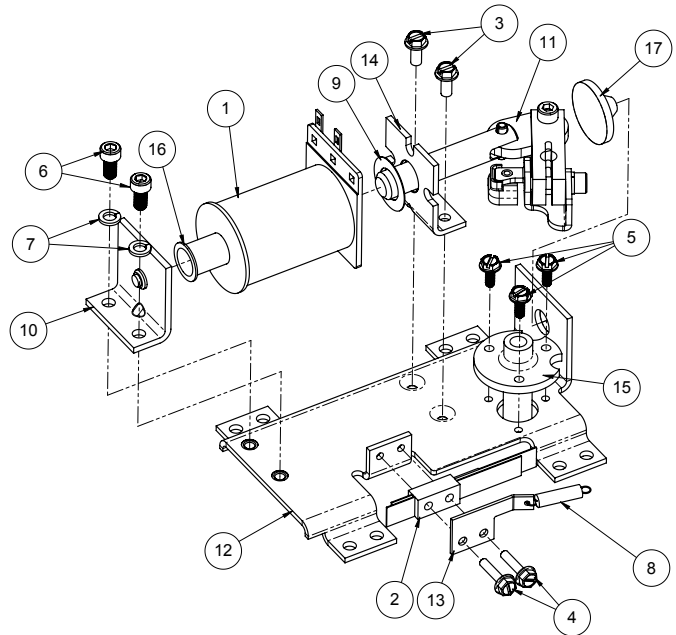

ID	Part Number	Description	Qty
1	090-5032-ND	FLIPPER COIL	1
2	180-5149-00	SWITCH, END-OF-STROKE	1
3	237-5975-00	SCREW, 8-32 X 3/8" HWH SWAGE ZN	2
4	237-5976-04	SCREW, 6-32 X 5/8" HWH SWAGE	2
5	237-6388-00	SCREW, 6-32 X 3/8", SLOTTED HWH, TYPE F	3
6	237-6389-00	SCREW, 10-32 X 3/8", SHC	2
7	244-5003-00	#10 LOCK WASHER, SPLIT	2
8	265-5035-00	EXTENSION SPRING	1
9	269-5002-00	SPRING WASHER	1
10	515-6308-01	COIL STOP ASSEMBLY	1
11	515-7203-01	PLUNGER / CRANK ASSEMBLY	1
12	535-7275-01	FLIPPER BASE PLATE, LEFT	1
13	535-7354-01	SWITCH PLATE / SPRING RTN BRKT	1
14	535-7356-00	COIL BRACKET	1
15	545-5070-00	FLIPPER BUSHING	1
16	545-5388-00	COIL SLEEVE	1
17	545-5428-00	RUBBER BUMPER	1
18	515-5133-08-06	FLIPPER BAT AND SHAFT	1
19	545-5277-00	FLIPPER RUBBER	1

ID	Part Number	Description	Qty
1	090-5032-ND	FLIPPER COIL	1
2	180-5149-00	SWITCH, END-OF-STROKE	1
3	237-5975-00	SCREW, 8-32 X 3/8" HWH SWAGE ZN	2
4	237-5976-04	SCREW, 6-32 X 5/8" HWH SWAGE	2
5	237-6388-00	SCREW, 6-32 X 3/8", SLOTTED HWH, TYPE F	3
6	237-6389-00	SCREW, 10-32 X 3/8", SHC	2
7	244-5003-00	#10 LOCK WASHER, SPLIT	2
8	265-5035-00	EXTENSION SPRING	1
9	269-5002-00	SPRING WASHER	1
10	515-6308-01	COIL STOP ASSEMBLY	1
11	515-7203-00	PLUNGER / CRANK ASSEMBLY	1
12	535-7275-00	FLIPPER BASE PLATE, RIGHT	1
13	535-7354-00	SWITCH PLATE / SPRING RTN BRKT	1
14	535-7356-00	COIL BRACKET	1
15	545-5070-00	FLIPPER BUSHING	1
16	545-5388-00	COIL SLEEVE	1
17	545-5428-00	RUBBER BUMPER	1
18	515-5133-08-06	FLIPPER BAT AND SHAFT	1
19	545-5277-00	FLIPPER RUBBER	1



# 5.15 POP BUMPER ASSEMBLY

516-6784-XX

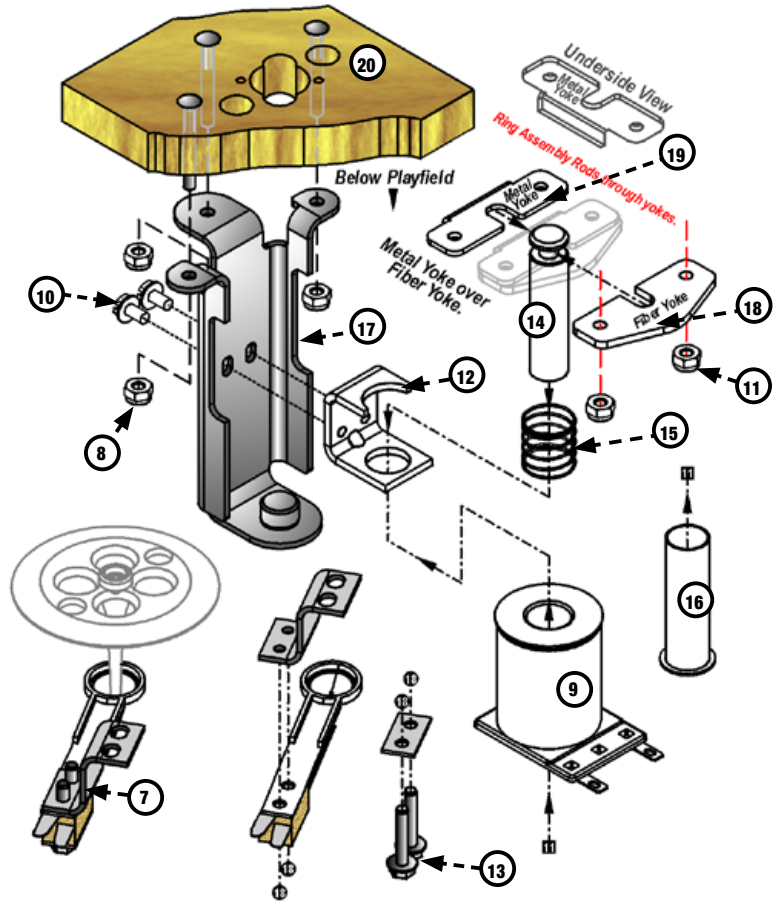
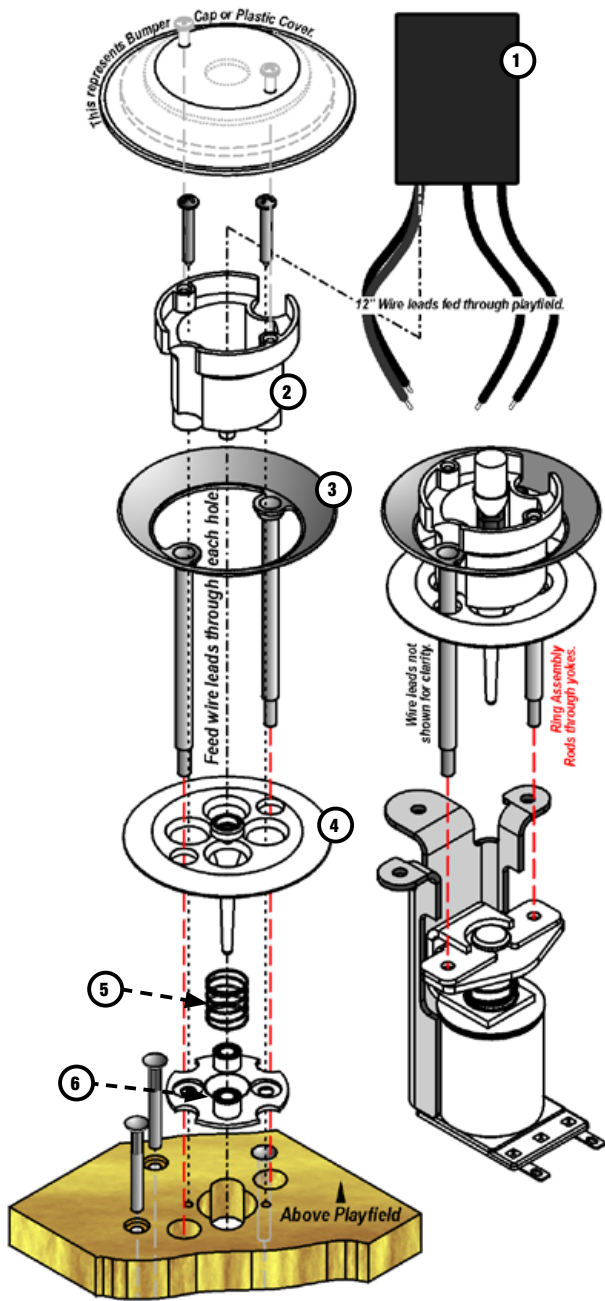

Part Number	Description	Qty
515-6459-01L	BUMPER/RING TOP ASSY, W/ LED 1	1
515-6459-04-ND	BUMPER BOTTOM ASSY, NO DIODE	1

ID	Part Number	Description	Qty
1	520-5307-03	POP BUMPER LED MODULE	1
2	545-5197-00	BUMPER BODY	1
3	515-5085-00	RING AND ROD ASSY	1
4	545-5607-00	BUMPER SKIRT	1
5	266-5048-00	BUMPER SKIRT COMP SPRING	1
6	545-5195-00	BUMPER BASE	1

ID	Part Number	Description	Qty
7	500-9934-01	POP BUMPER SWITCH ASSY-2 - LUG-LEFT	1
8	240-5005-00	6-32 NYLON STOP NUT	3
9	090-5044-ND	COIL - 26-1200	1
10	237-5976-01	#6-32 X 1/4" SHWH SWAGE ZN	2
11	240-5005-00	#6-32 NYLON STOP NUT	2
12	535-7347-00	METAL YOKE STOP	1
13	234-5101-00	* 8 X 1/2 SLT	6
14	530-5348-00	PLUNGER, POP BUMPER	1
15	266-5047-00	COMPRESSION SPRING, POP BUMPER	1
16	545-5031-00	COIL SLEEVE	1
17	515-5939-00	COIL BRACKET POP BUMPER ASSY	1
18	545-5609-00	FIBER YOKE	1
19	535-7346-00	METAL YOKE	1
20	237-5957-00	#6-32 x 1-3/16" SPIRAL FIN SHANK SCREW	3



## 5.16 BOTTOM ARCH ASSEMBLY

500-2505-XX

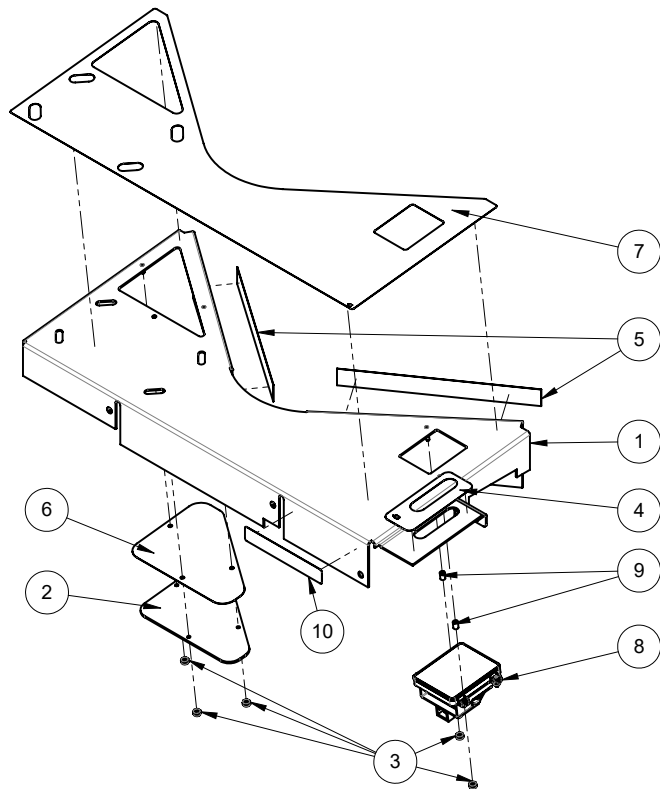

ID	Part Number	Description	Qty
1	510-7805-00	BOTTOM ARCH, STEEL W/ SPADE BOLT, QR READY	1
2	830-8502-XX	LEFT SIDE ARCH PLASTIC	1
3	240-5303-00	4-40 NYLON LOCK NUT	5
4	820-97XX-02	METAL ARCH DECAL SET -02	1
5	545-5212-04	MYLAR PROTECT STRIP 7-5/8"	2
6	545-9923-00	COVER, SIGNATURE PROTECTOR, METAL ARCH	1
7	820-97XX-01	METAL ARCH DECAL SET -01	1
8	509-2020-00	QR SCANNER M306 ASSEMBLY	1
9	254-5090-04	PLASTIC SPACER #4 SCREW, 3/16" OD - 9/32" LENGTH	2
10	820-5422-00	WARNING DECAL, BOTTOM ARCH, QR READER	1

## 5.17 BALL DEFLECTOR ASSEMBLY

500-7081-00

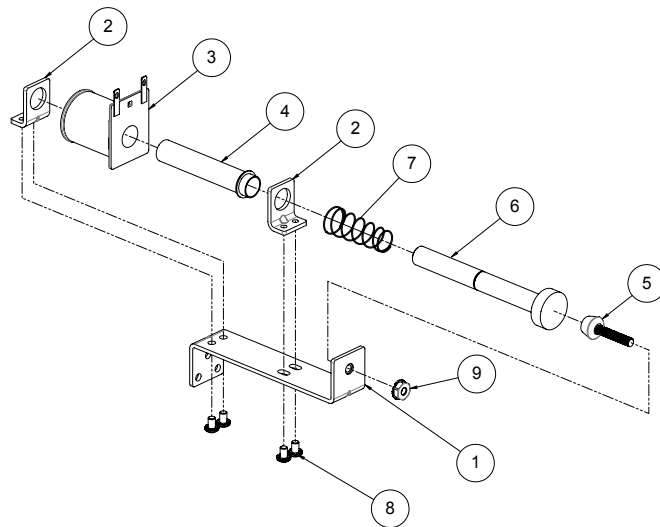

ID	Part Number	Description	Qty
1	535-9248-00	BRACKET	1
2	535-5203-03	COIL RETAINING BRACKET	2
3	090-5044-ND	COIL 26-1200 - NO DIODE	1
4	545-5847-00	COIL SLEEVE	1
5	280-5014-00	ADJUSTABLE BUMPER/STOP	1
6	515-7653-00	PLUNGER ASSEMBLY	1
7	266-5020-00	COMPRESSION SPRING-CONICAL	1
8	232-5300-00	SCREW, 8-32 X 1/4" PPH SEMS	4
9	240-5208-00	10-32 KEPS NUT	1

## 5.18 3-BANK DROP TARGET ASSEMBLY

500-1110-03-0-1

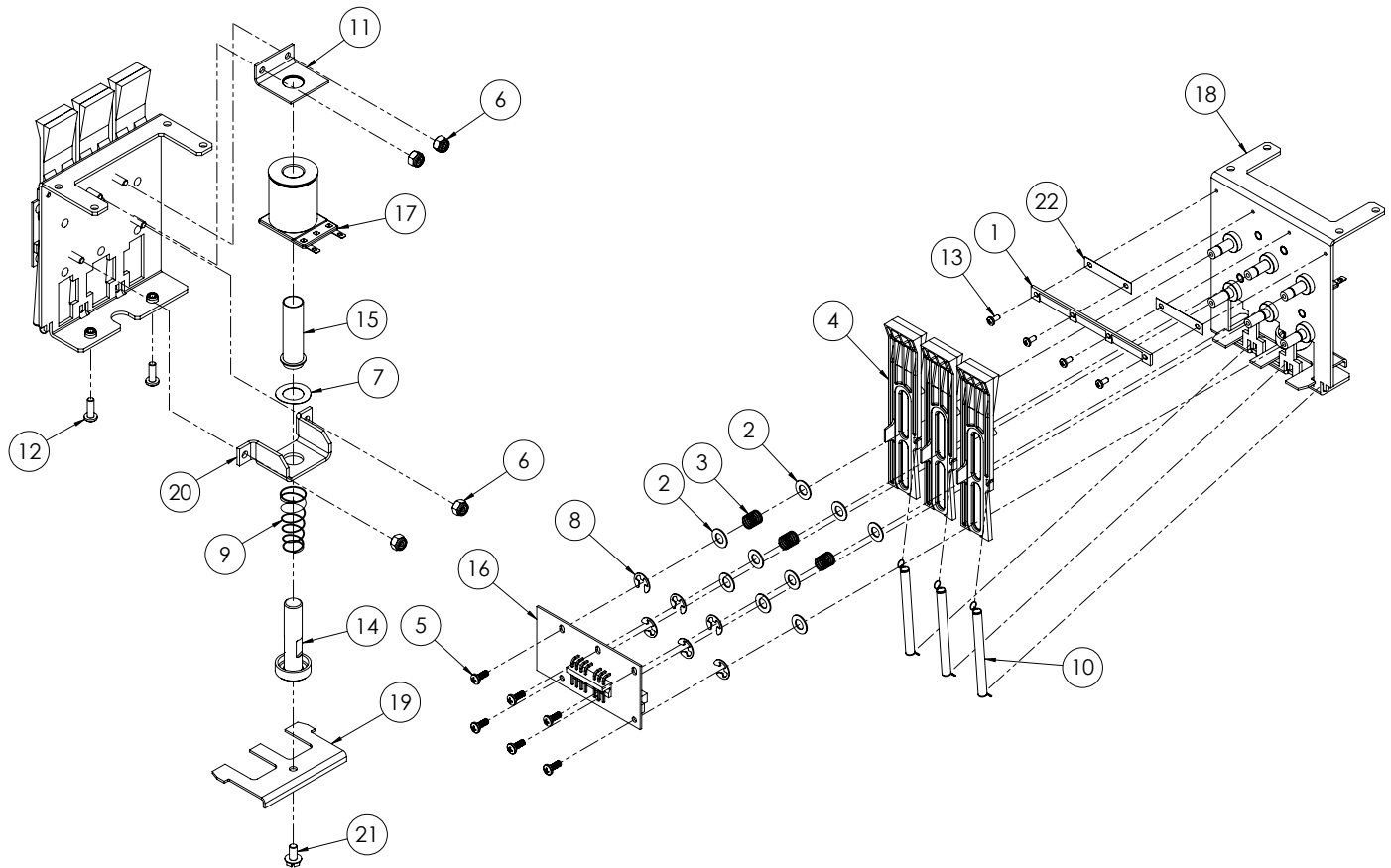

ID	Part Number	Description	Qty
1	545-6163-03	LEDGE, 3-BANK DROP TARGET	1
2	242-5091-00	WASHER, 1/2 X 17/64 X .03 - DT	9
3	266-5089-00	SPRING COMPRESSION - DT	3
4	545-6305-00	TARGET - ROLLOVER	3
5	237-5501-00	SCREW, 6-32 X 3/8" PPH MS ZINC	6
6	240-5102-00	8-32 NYLON LOCK NUT	4
7	269-5002-00	SPRING WASHER	1
8	270-5002-00	RETAINING RING - 1/4"	6
9	266-5020-00	COMPRESSION SPRING-CONICAL	1
10	265-5003-02	TARGET RESET SPRING	3
11	535-9959-00	STOP BRKT	1

12	237-5602-00	SCREW, 8-32 X 1/2" PPH MS ZINC	2
13	237-6169-00	SCREW, 4-40 X 1/4 PPH MS	4
14	530-5757-00	PLUNGER - D.T. ASSY.	1
15	545-5076-01	COIL SLEEVE	1
16	520-5252-13	3 BANK DROP TARGET PCB-OPTO, W/ RIGHT ANGLE CONN	1
17	090-5034-ND	COIL 25-1240 - NO DIODE	1
18	515-9927-03	DROP TARGET FRAME ASSY - 3-BANK	1
19	535-9996-03	LIFT BRACKET - 3 BANK	1
20	535-9995-01	COIL BRACKET	1
21	237-5985-00	SCREW, 10-32 X 3/8" HWH SWAGE	1
22	545-6798-00	SHIM - FICHE PAPER - D.T. SINGLE	2

## 5.19 FISHING REEL SPINNER ASSEMBLY

511-3073-01

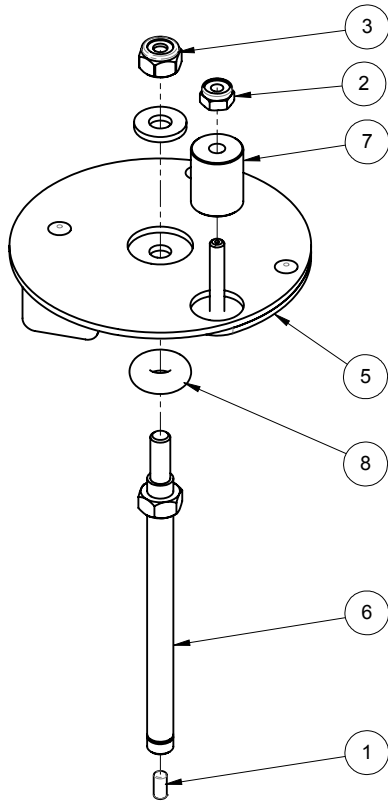

ID	Part Number	Description	Qty
1	090-5096-00	MAGNET, 1/8 X .250", DIAM. MAGNETIZED	1
2	240-5005-00	6-32 NYLON STOP NUT	1
3	240-5203-00	10-32 NYLON LOCK NUT	1
4	242-5003-00	#10 FLAT WASHER - 1/2" O.D. X .062 THICK	1
5	510-1088-01	RIVETED ASM, FISHING REEL SPINNER	1
6	530-2738-00	SHAFT, SHIP WHEEL SPINNER	1
7	530-2738-01	WEIGHT, FISHING REEL	1
8	545-5348-01	RUBBER RING, BLACK, 3/16" ID	1

## 5.20 LOWER HORIZONTAL SPINNER ASSEMBLY

511-3074-00

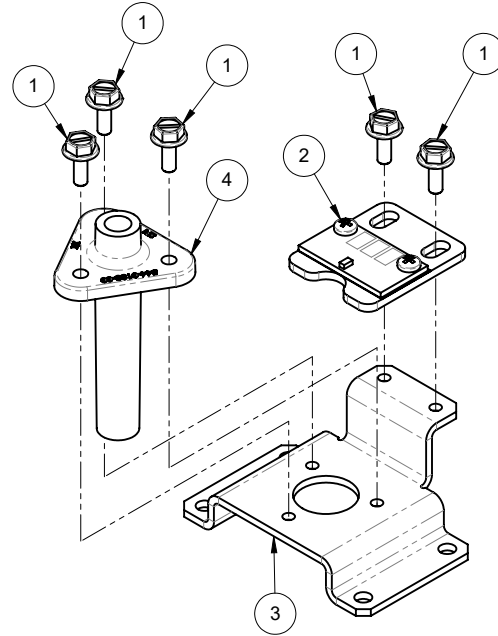

ID	Part Number	Description	Qty
1	237-5976-02	SCREW, 6-32 X 3/8" HWH SWAGE	5
2	511-2895-00	HELICOPTER MAG SENSOR	1
3	535-2841-00	BRACKET, SHIP WHEEL SPINNER	1
4	545-5070-00	BUSHING, HORIZONTAL SPINNER	1

### 5.21 SHARK FIN ASSEMBLY

500-3636-00

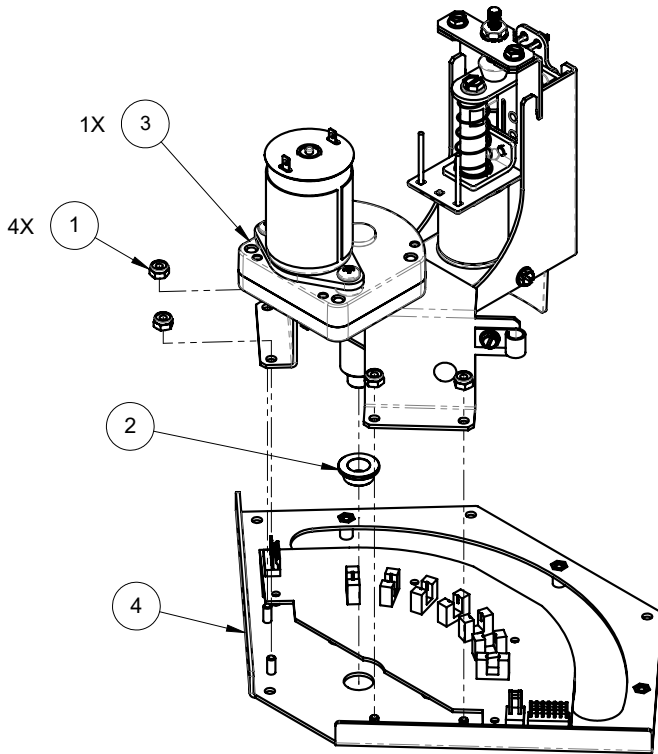

ID	Part Number	Description	Qty
1	240-5005-00	6-32 NYLON STOP NUT	4
2	283-5018-07	3/8 ID X 1/2 OD X 1/4 LG. BUNTING SAE 841 BRONZE FLANGED BEARING - PART #EF060804	1
3	511-3080-03	SHARK FIN MOTOR ASSEMBLY	1
4	511-3080-04	SHARK FIN MAIN BRACKET ASSEMBLY	1

### 5.22 SHARK FIN ARM ASSEMBLY

511-3080-00

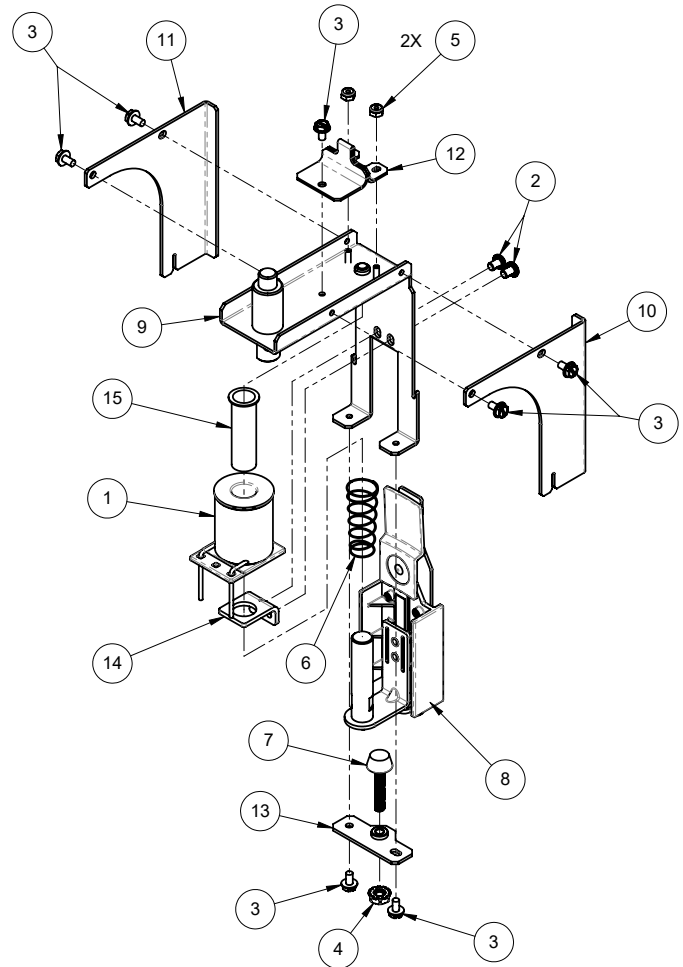

ID	Part Number	Description	Qty
1	090-5091-00	COIL, 26-1200, NO DIODE, LUGLESS	1
2	232-5300-00P	SCREW, 8-32 X 1/4" PPH SEMS, PATCH	2
3	237-5976-01	SCREW, 6-32 X 1/4 HWH SWAGE	7
4	240-5208-00	10-32 KEPS NUT	1
5	240-5303-00	4-40 NYLON LOCK NUT	2
6	266-5020-00	COMPRESSION SPRING-CONICAL	1
7	280-5014-00	ADJUSTABLE BUMPER/STOP	1
8	511-3080-02	ASM, FIN TARGET	1
9	515-2812-00	WELDMENT, SHARK FIN, MAIN ARM	1
10	535-2853-03	BRACKET, TARGET SLIDE, RIGHT	1
11	535-2853-04	BRACKET, TARGET SLIDE, LEFT	1
12	535-2853-06	BRACKET, OPTO INTERRUPTER	1
13	535-2853-07	BRACKET, FIN LEVELING NUT	1
14	535-5203-03	COIL RETAINING BRACKET	1
15	545-5031-00	COIL SLEEVE	1

### 5.23 SHARK FIN PLATE ASSEMBLY 511-3080-01

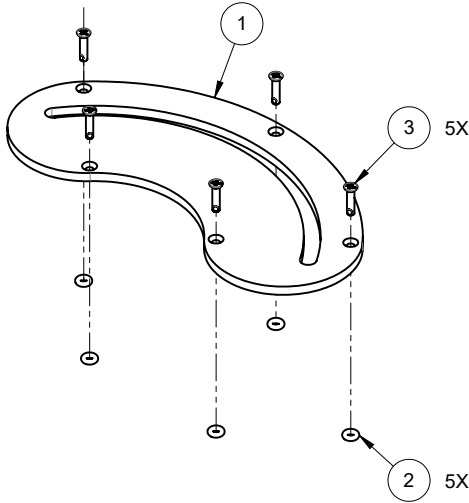

ID	Part Number	Description	Qty
1	545-2738-00	PLATE, SHARK FIN, FILLER	1
2	545-9991-01	RUBBER RING-VITON, 75A DUROMETER	5
3	237-6172-00P	SCREW, 6-32 X 5/8" PFH ZINC, PATCH	5

### 5.24 SHARK FIN MAIN BRACKET ASSEMBLY 511-3080-04

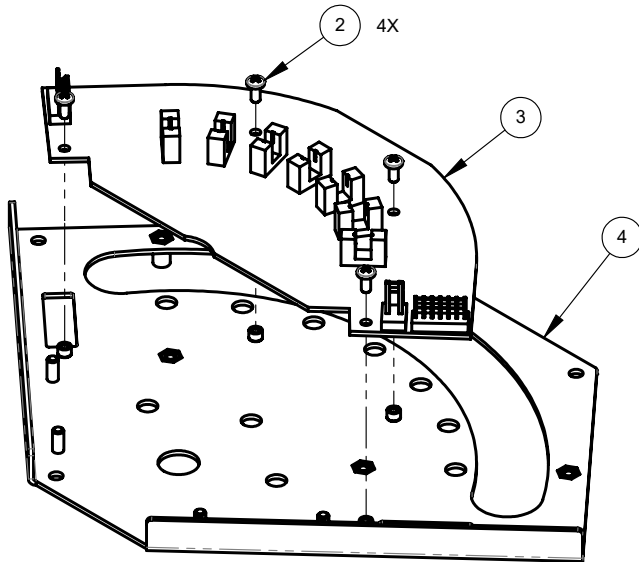

ID	Part Number	Description	Qty
1	000-0698-00	LOCTITE THREAD LOCK 222 "PURPLE LOW STR"	
2	237-6169-00P	SCREW, 4-40 X 1/4 PPH MS, PATCH	4
3	520-1059-00	PCA, JAWS, SHARK FIN	1
4	535-2853-00	BASE BRACKET, SHARK FIN	1
	234-5101-00	SCREW, 8 X 1/2 SLT HWH AB ZINC	4

### 5.25 SHARK FIN TARGET ASSEMBLY 511-3080-02

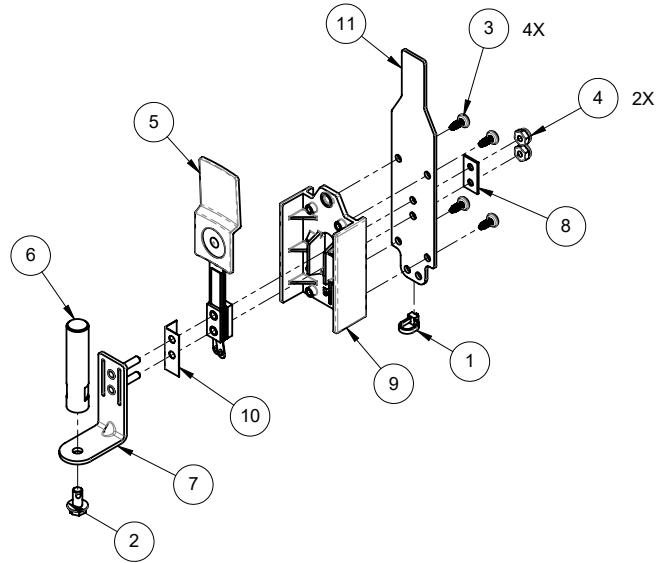

ID	Part Number	Description	Qty
1	040-5001-08	CABLE TIE, BLACK	1
2	237-5961-00P	SCREW, 10-32 X 3/8" HWH, PATCH	1
3	237-6393-00	SCREW, #6 x 5/16" PPH THREAD CUTTING	4
4	240-5005-00	6-32 NYLON STOP NUT	2
5	510-1059-00	RIVETED ASM, FIN TARGET	1
6	530-8053-01	PLUNGER, SHARK FIN	1
7	535-2853-05	BRACKET, TARGET LIFT	1
8	535-7344-00	SWITCH PLATE	1
9	544-7650-00	TARGET SLIDE	1
10	545-7874-00	FISCHE PAPER - S/U TARGET	1
11	555-0001-00	SUPPORT, SHARK FIN TARGET	1

## 5.26 SHARK FIN MOTOR ASSEMBLY 511-3080-03

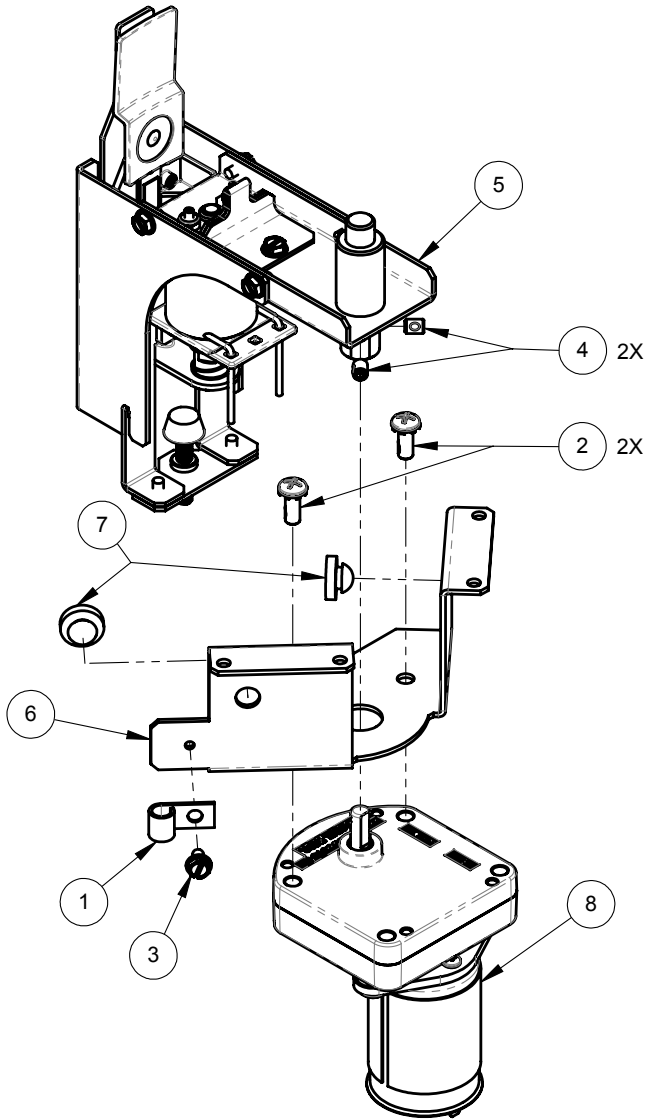

ID	Part Number	Description	Qty
1	040-5000-03	1/4" CABLE CLAMP	1
2	232-5402-00P	SCREW, 10-32 X 1/2" PPH MS SEMS, PATCH	2
3	237-5976-01	SCREW, 6-32 X 1/4 HWH SWAGE	1
4	237-6310-00	SET SCREW, 10-32 X 1/4", SOCKET CUP PT	2
5	511-3080-00	ASSEMBLY: SHARK FIN ARM	1
6	535-2853-11	2IN MOTOR BRACKET, SHARK FIN	1
7	545-5105-00	RUBBER BUMPER	2
8	511-3111-09	MOTOR ASM, MP 8000D W/ CAP	1

## 5.27 CHUM BUCKET FULL ASSEMBLY

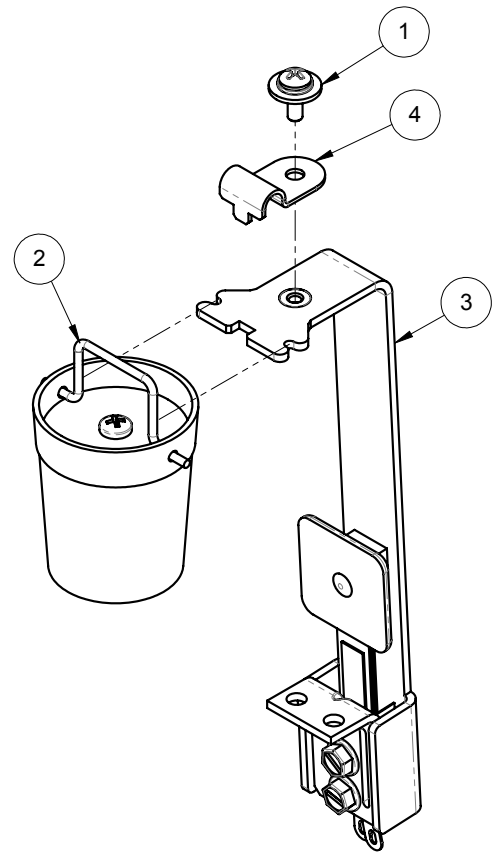

ID	Part Number	Description	Qty
1	237-6378-00	#6-32 X 3/8 PAN PHILLIPS w/DOUBLE SEMS	1
2	511-4094-00	ASM, CHUM BUCKET, LE	1
3	511-5094-00	ASM, CHUM BUCKET, TARGET	1
4	535-2864-01	BRACKET, CHUM BUCKET, RETAINER	1

## 5.28 CHUM BUCKET TARGET ASSEMBLY

511-4083-00

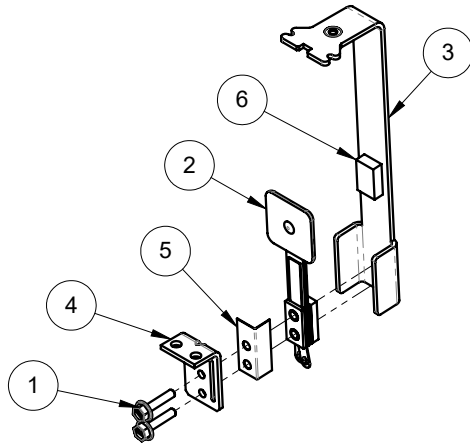

ID	Part Number	Description	Qty
1	237-5976-04	SCREW, 6-32 X 5/8" HWH SWAGE, SERRATED	2
2	515-9783-00-00	1" SQ. TARGET SWITCH - ANTILOFT- 2 LUG - BLACK	1
3	535-2864-00	HANGER BRACKET, CHUM BUCKET	1
4	535-6896-01	TARGET BRACKET - SLOTTED	1
5	545-7874-00	FISCHE PAPER - S/U TARGET	1
6	626-5078-00	3/16" FOAM PAD	1

## 5.29 CHUM BUCKET ASSEMBLY

511-4094-00

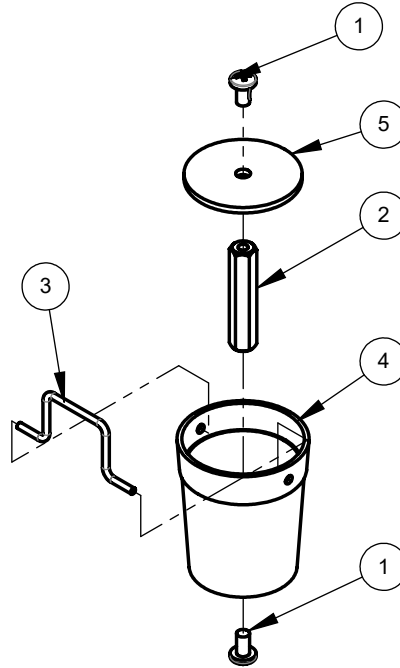

ID	Part Number	Description	Qty
1	237-5500-01P	SCREW, 6-32 X 1/4" PPH MS BLACK, PATCH	2
2	254-5008-11	HEX SPACER - 1 1/4 "	1
3	535-2865-00	WIRE, CHUM BUCKET	1
4	545-7659-00	TOY, CHUM BUCKET	1
5	830-8523-22	PLASTIC, JAWS PRE/LE -22	1



### 5.30 HELICOPTER SENSOR ASSEMBLY 511-2895-00

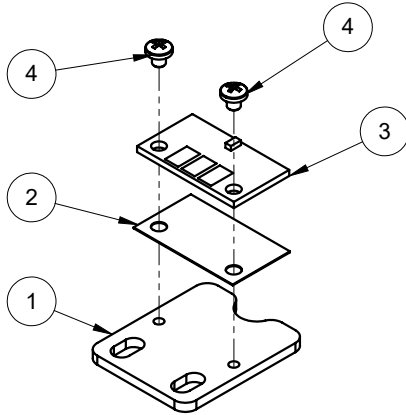

ID	Part Number	Description	Qty
1	535-2214-00	BRACKET, HELI MAG SENSOR	1
2	523-0020-00	FISHCE PAPER, MAG SENSOR	1
3	520-8442-00	MAG SENSOR BOARD	1
4	237-6355-00	SCREW, 4-40 X 1/8" PPH MS	2

### 5.31 HARPOON GATE ASSEMBLY 511-4093-00

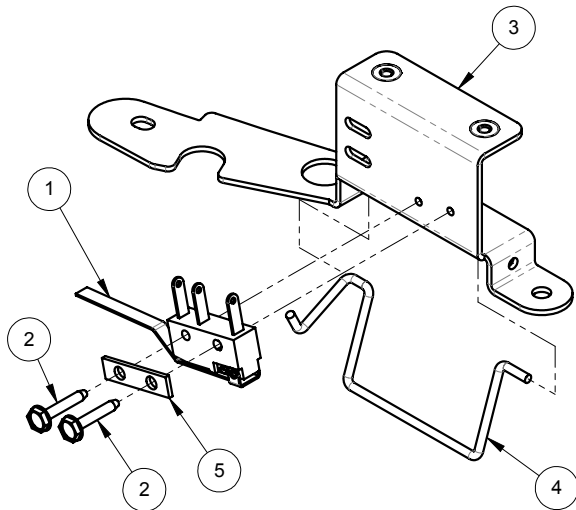

ID	Part Number	Description	Qty
1	180-5087-00	SWITCH - GATE	1
2	237-5937-02P	SCREW, 2-56 X 1/2" HWH MS, PATCH	2
3	535-2861-04	BRACKET, SWITCH GATE	1
4	535-2861-05	WIRE, SWITCH GATE	1
5	535-6539-00	SWITCH BODY PROTECT PLATE	1

### 5.32 REFLECTIVE OPTO SPINNER ASSEMBLY 511-3044-00

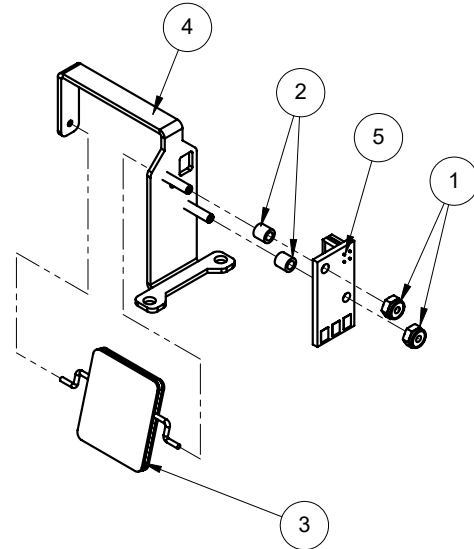

ID	Part Number	Description	Qty
1	240-5303-00	4-40 NYLON LOCK NUT	2
2	254-5090-01	PLASTIC SPACER #4 SCREW, 3/16" OD - 3/16" LENGTH	2
3	515-2326-00	SPINNER TARGET, REFLECTIVE OPTO	1
4	515-2456-00	BRACKET, SPINNER, REFLECTIVE OPTO	1
5	520-8541-00	PCA SPINNER REFLECTIVE OPTIC	1

### 5.33 INLANE GATE ASSEMBLY 511-4092-00

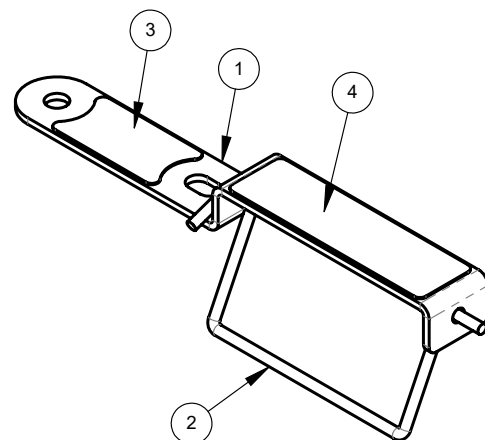

ID	Part Number	Description	Qty
1	535-2861-00	BRACKET, INLANE GATE, JAWS	1
2	535-2862-00	WIRE, ONE WAY GATE, INLANE	1
3	820-1436-71	DECAL, JAWS PRE/LE -71	1
4	820-1436-72	DECAL, JAWS PRE/LE -72	1

### 5.34 SHARK ASSEMBLY

500-2679-00

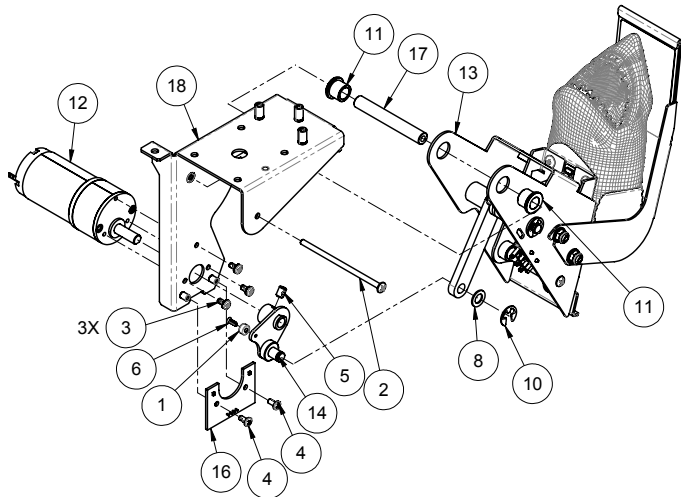

ID	Part Number	Description	Qty
1	090-5097-00	MAGNET, 1/4" X .125", #2 CSINK, AXIAL	1
2	237-5906-00P	SCREW, 6-32 X 2-3/4" PPH MS, PATCH	1
3	237-6188-01P	SCREW, M3x0.5 X 6MM PPH SEMS ZINC, PATCH	3
4	237-6169-00P	SCREW, 4-40 X 1/4 PPH MS, PATCH	2
5	237-6310-00P	SET SCREW, 10-32 X 1/4", SOCKET CUP PT, PATCH	1
6	237-6366-00	2-56 x 1/4" PFH MS	1
7	240-5005-00	6-32 NYLON STOP NUT	1
8	242-5012-00	WASHER, 1/4 X 7/16 X 1/32	1
9	254-5000-19	NYLON SPACER - BLACK - 3/8 OD X .175 ID X 1/8"	1
10	270-5002-00	RETAINING RING - 1/4"	1
11	283-5018-00	5/16 ID X 7/16 OD X 3/8 LG. BUNTING SAE 841 BRONZE FLANGED BEARING-PART #EF050706	2
12	511-3081-03	MOTOR ASM, MP 04105132-00, W/ CAPS	1
13	511-8873-01	ASM, SHARK, LIFT PLATFORM	1
14	515-2820-02	CRANK, SHARK	1
15	520-7000-00	SINGLE FLASH LED BOARD	1
16	520-8470-00	PCA MAG SENSOR DUAL 180 OMNI	1
17	530-8054-50	SHAFT, SHARK PIVOT	1
18	535-2854-50	BRACKET, SHARK, BASE	1

### 5.35 SHARK LIFT PLATFORM ASSEMBLY

511-8873-01

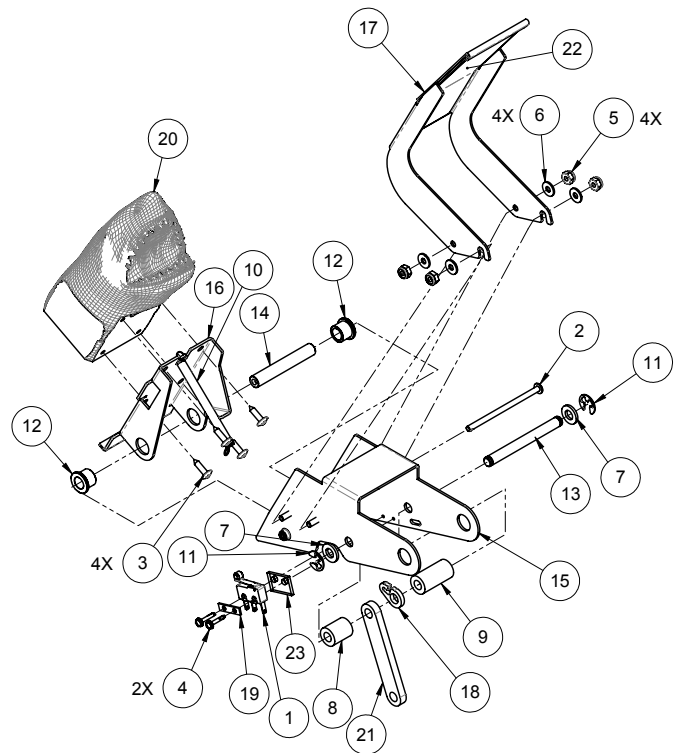

ID	Part Number	Description	Qty
1	180-5119-02	MICRO-SWITCH - LIGHT ACTUATION	1
2	237-5514-01P	SCREW, 6-32 X 2-1/2" PPH MS, PATCH	1
3	237-5809-00	SCREW, #6 X 1/2" PTH A	4
4	237-5937-02P	SCREW, 2-56 X 1/2" HWH MS, PATCH	2
5	240-5005-00	6-32 NYLON STOP NUT	4
6	242-5001-00	#6 WASHER	4
7	242-5008-00	WASHER, 1/4" ID X 1/2" OD X 1/16" THICK	2
8	254-5099-09	SPACER, NYLON, 1/4" ID	1
9	254-5099-15	SPACER, NYLON, 1/4" ID	1
10	265-5003-03	TARGET RESET SPRING	1
11	270-5002-00	RETAINING RING - 1/4"	2
12	283-5018-00	5/16 ID X 7/16 OD X 3/8 LG. BUNTING SAE 841 BRONZE FLANGED BEARING-PART #EF050706	2
13	530-7865-00	PIVOT PIN-.250" DIA.	1
14	530-8054-51	SHARK PIVOT, SHORT SHAFT	1
15	535-2854-51	BRACKET, SHARK LIFT FRAME	1
16	535-2854-52	BRACKET, SHARK SWITCH PLATE	1
17	535-2854-54	SHARK LIFT HOOD	1
18	535-2854-55	HOOK SPRING	1
19	535-6539-00	SWITCH BODY PROTECT PLATE	1
20	545-7671-00	SHARK TOY	1
21	546-5009-01	LINK, SHARK LIFT	1
22	820-1436-68	DECAL, JAWS PRE/LE -68	1
23	830-6117-00	SWITCH SPACER	1

### 5.36 SHARK PLAYFIELD PROTECTOR ASSEMBLY

511-8873-10

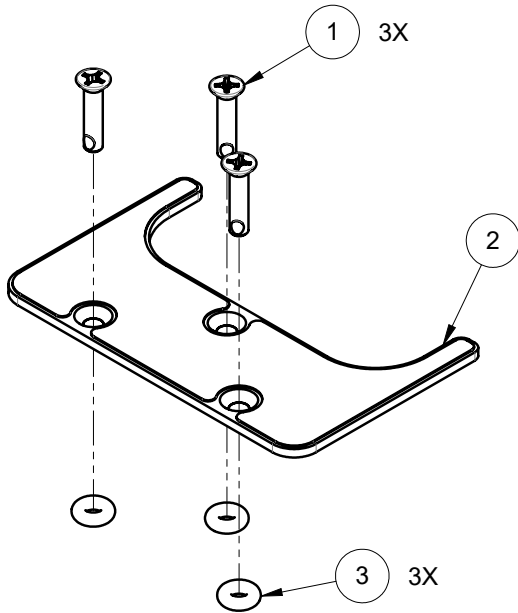

ID	Part Number	Description	Qty
1	237-6172-00P	SCREW, 6-32 X 5/8" PFH ZINC, PATCH	3
2	535-2854-06	PLATE, SHARK PLAYFIELD PROTECTOR	1
3	545-9991-00	RUBBER RING-VITON, 90A DUROMETER	3
4	820-1436-75	DECAL, JAWS PRE/LE , -75	1

### 5.37 QUINT'S SHACK ASSEMBLY

511-5400-00

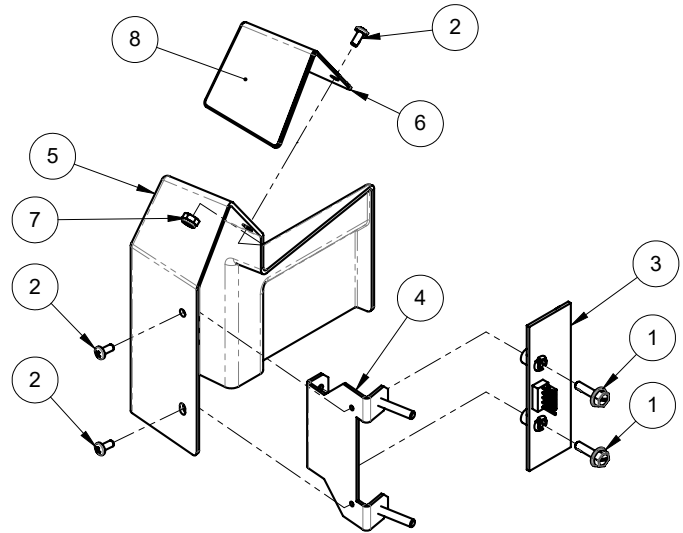

ID	Part Number	Description	Qty
1	237-5976-03P	SCREW, 6-32 X 1/2" HWH MS, PATCH	2
2	237-6331-00P	SCREW, 4-40 X 1/4" PPH MS BLACK, PATCH	3
3	520-7011-00	LAMP PCB, 3-LED, CONSUMER PIN	1
4	535-2861-06	BRACKET, LAMP BOARD, SHACK	1
5	545-7660-00	BUILDING, QUINT'S SHACK	1
6	535-0016-00	BRACKET, QUINT'S SHACK, ROOF	1
7	240-5303-00	4-40 NYLON LOCK NUT	1
8	820-1436-83	DECAL, JAWS PRE/LE -83	1

# 5.38 BOAT ASSEMBLY

511-8873-30

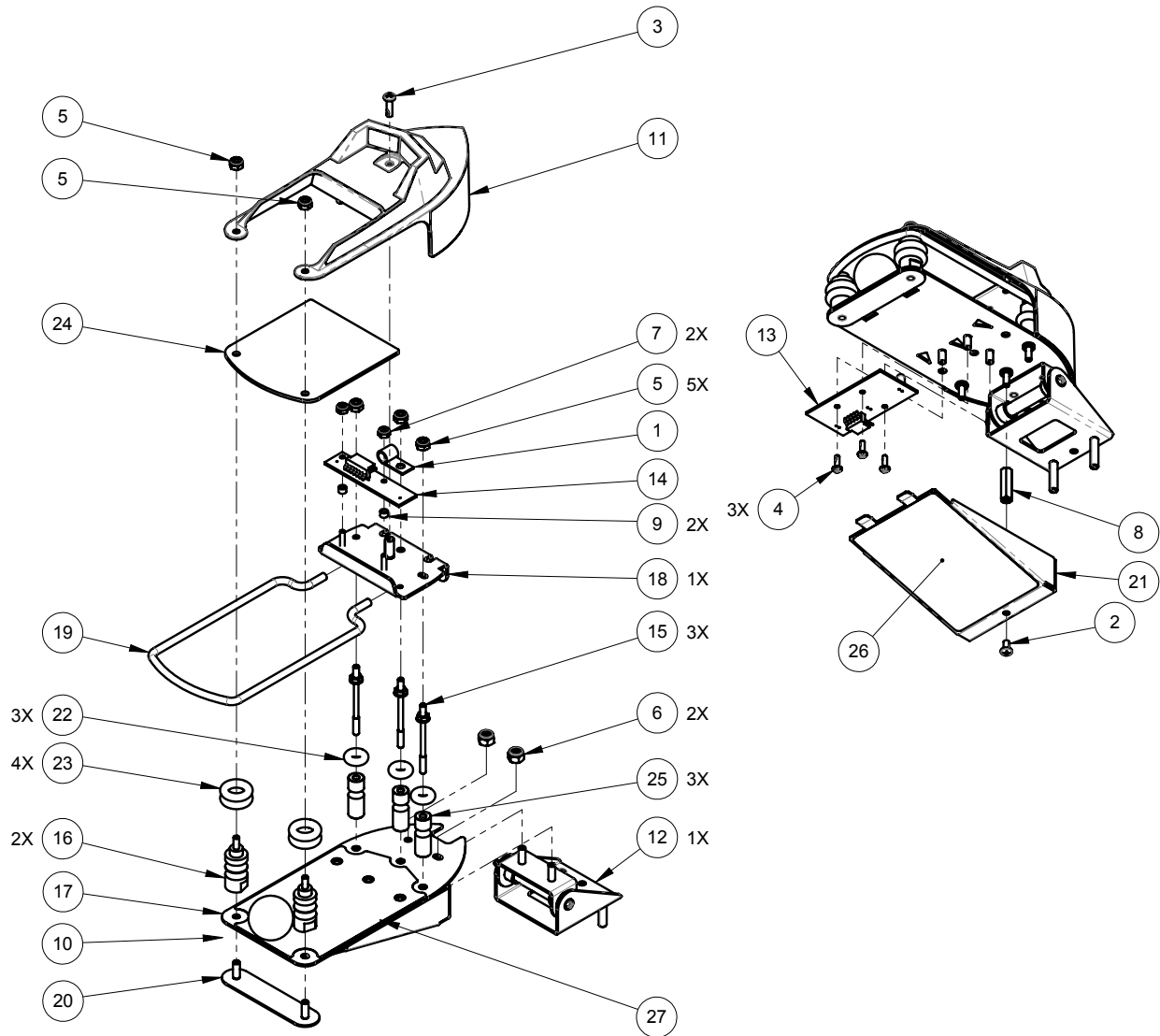

ID	Part Number	Description	Qty
1	040-5000-03	1/4" CABLE CLAMP	1
2	237-5500-01P	SCREW, 6-32 X 1/4" PPH MS BLACK, PATCH	1
3	237-5502-03P	SCREW, 6-32 X 1/2" PPH MS BLACK, PATCH	1
4	237-5909-01P	SCREW, 4-40 X 3/8" PPH SEMS, PATCH	3
5	240-5005-00	6-32 NYLON STOP NUT	5
6	240-5102-00	8-32 NYLON LOCK NUT	2
7	240-5303-00	4-40 NYLON LOCK NUT	2
8	254-5008-05	HEX SPACER - 7/8"	1
9	254-5090-03	PLASTIC SPACER #4 SCREW, 3/16" OD - 1/8" LENGTH	2
10	260-5000-00	BALL, CARBON - 1.0625" DIA.	1
11	511-8873-31	ASM, BOAT W/ DECALS	1
12	511-8873-32	ASM, BOAT HINGE	1
13	520-1075-00	3 OPTO EMITTER PCA	1

14	520-5378-00	3 OPTO RECEIVER PCB	1
15	530-5012-02	6-32 POST SCREW	3
16	530-8054-30	POST, NEWTON BALL	2
17	535-2854-31	PLATE, BOAT NEWTON BALL	1
18	535-2854-32	BRACKET, BOAT, TOP	1
19	535-2854-33	WIRE, BOAT NEWTON BALL	1
20	535-2854-34	PLATE, POST MOUNT	1
21	535-2854-36	COVER, BOAT OPTO, LOWER	1
22	545-5348-01	3/16" ID RUBBER RINGS - BLACK	3
23	545-5348-03	3/8" ID RUBBER RINGS - BLACK	4
24	546-5009-00	COVER, BOAT NEWTON BALL	1
25	550-5059-01	PLASTIC POST - CLEAR	3
26	820-0107-00	MYLAR, BOAT BOTTOM	1
27	820-1436-70	DECAL, JAWS PRE/LE, -70	1

### 5.39 BOAT DECALS

511-8873-31

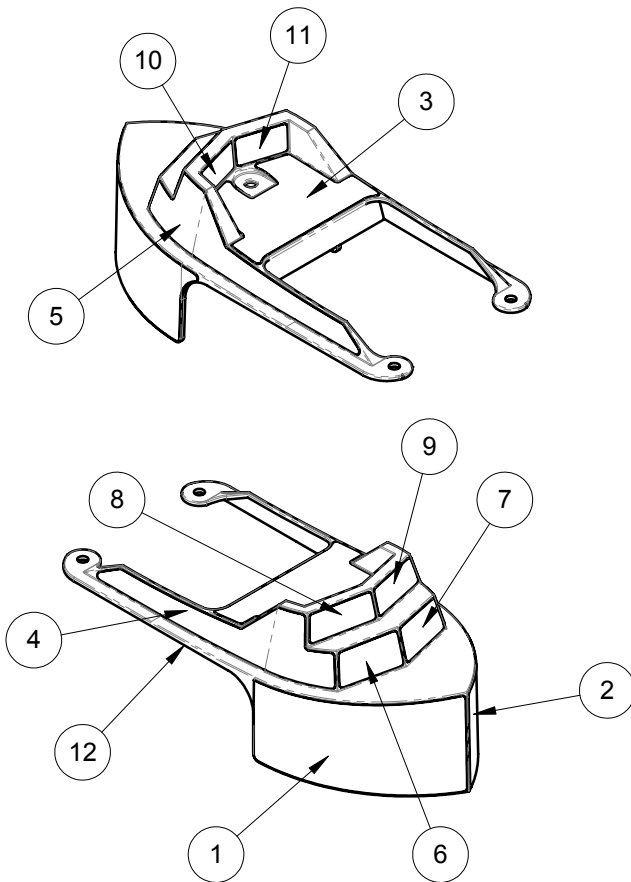

ID	Part Number	Description	Qty
1	820-1436-50	DECAL, JAWS PRE/LE, -50	1
2	820-1436-51	DECAL, JAWS PRE/LE, -51	1
3	820-1436-53	DECAL, JAWS PRE/LE, -53	1
4	820-1436-54	DECAL, JAWS PRE/LE, -54	1
5	820-1436-55	DECAL, JAWS PRE/LE, -55	1
6	820-1436-56	DECAL, JAWS PRE/LE, -56	1
7	820-1436-57	DECAL, JAWS PRE/LE, -57	1
8	820-1436-58	DECAL, JAWS PRE/LE, -58	1
9	820-1436-59	DECAL, JAWS PRE/LE, -59	1
10	820-1436-60	DECAL, JAWS PRE/LE, -60	1
11	820-1436-61	DECAL, JAWS PRE/LE, -61	1
12	544-5996-00	TOY BOAT, JAWS PRE/LE	1

### 5.40 BOAT HINGE ASSEMBLY

511-8873-32

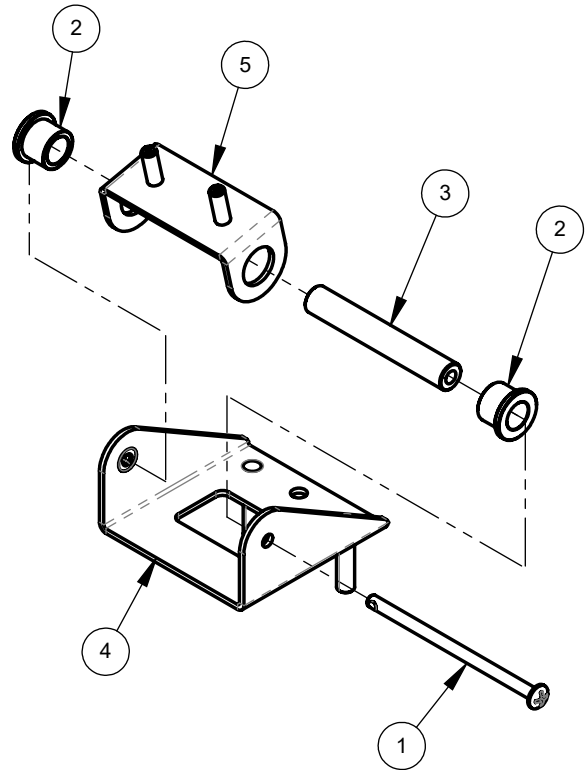

ID	Part Number	Description	Qty
1	237-5514-01P	SCREW, 6-32 X 2-1/2" PPH MS, PATCH	1
2	283-5018-00	5/16 ID X 7/16 OD X 3/8 LG. BUNTING SAE 841 BRONZE FLANGED BEARING-PART #EF050706	2
3	530-8054-51	SHAFT, SHARK PIVOT, SHORT	1
4	535-2854-07	BRACKET, BOAT HINGE	1
5	535-2854-30	BRACKET, BOAT PIVOT	1

### 5.41 PLASTIC 03 ASSEMBLY

511-3097-03

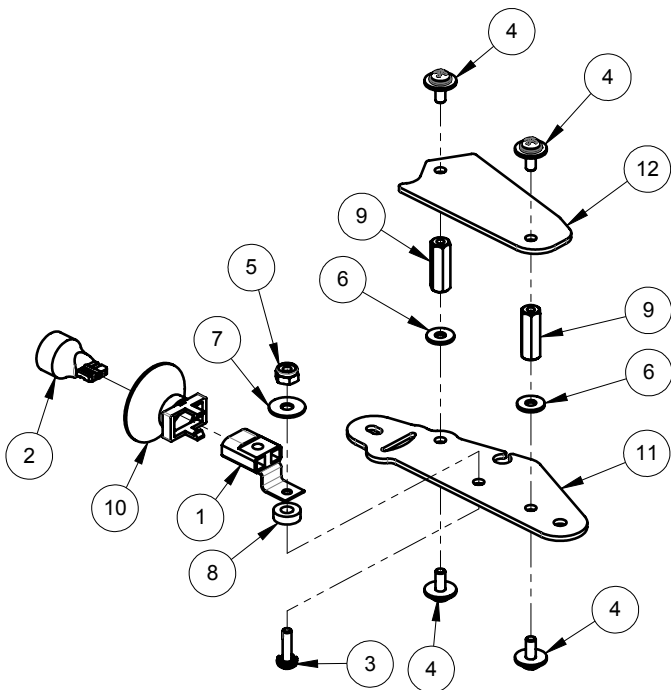

ID	Part Number	Description	Qty
1	077-5026-01	SOCKET, L/D WEDGE BASE BLACK	1
2	113-5032-08	8 ELEMENT FLAT W-BASE LED 5V AC - WHITE	1
3	232-5202-00P	SCREW, 6-32 X 1/2" PPH MS SEMS, PATCH	1
4	237-6378-00P	#6-32 X 3/8 PAN PHILLIPS w/DOUBLE SEMS, PATCH	4
5	240-5005-00	6-32 NYLON STOP NUT	1
6	242-5001-00	#6 WASHER	3
7	242-5015-00	#8 WASHER - .170 ID X 1/2 OD X .042	1
8	254-5000-19	NYLON SPACER - BLACK - 3/8 OD X .175 ID X 1/8"	1
9	254-5008-04	HEX SPACER - 3/4 "	2
10	545-5409-01	REFLECTOR	1
11	830-8523-03	PLASTIC, JAWS PRE/LE -03	1
12	830-8523-53	PLASTIC, JAWS PRE/LE -53	1

### 5.42 PLASTIC 05 ASSEMBLY

511-3097-05

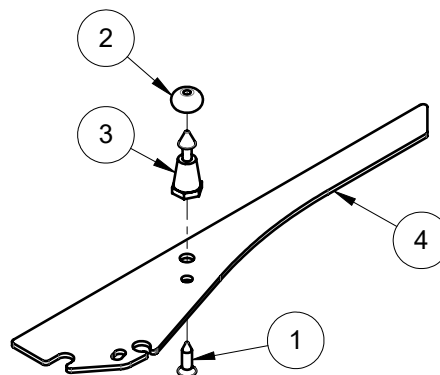

ID	Part Number	Description	Qty
1	237-5800-00	SCREW, #6 X 1/2" PFH ZINC	1
2	545-5348-17	7/16 O.D. RUBBER RING - BLACK	1
3	550-5052-01	MINI POST - CLEAR	1
4	830-8523-05	PLASTIC, JAWS PRE/LE -05	1

### 5.43 PLASTIC 13 ASSEMBLY

511-3097-13

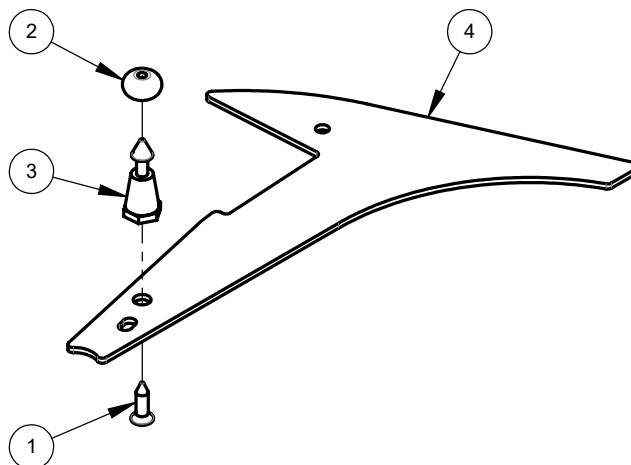

ID	Part Number	Description	Qty
1	237-5800-00	SCREW, #6 X 1/2" PFH ZINC	1
2	545-5348-17	7/16 O.D. RUBBER RING - BLACK	1
3	550-5052-01	MINI POST - CLEAR	1
4	830-8523-13	PLASTIC, JAWS PRE/LE -13	1

### 5.44 PLASTIC 17 ASSEMBLY

511-3097-17

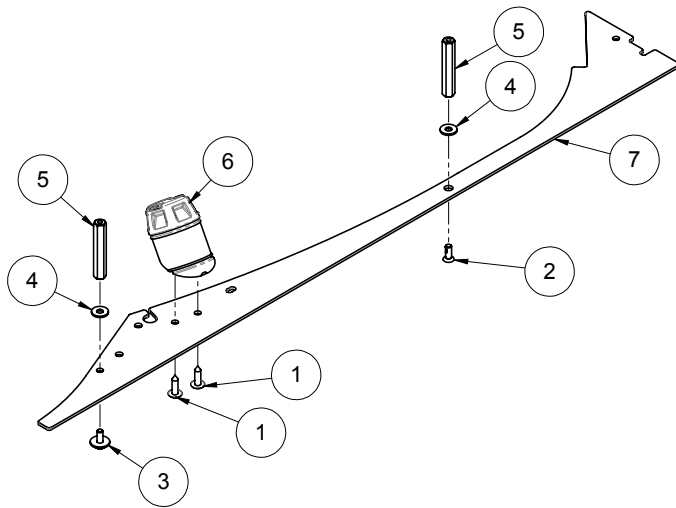

ID	Part Number	Description	Qty
1	237-5809-00	SCREW, #6 X 1/2" PTH A	2
2	237-5871-00P	SCREW, 6-32 X 3/8" PFH 82° U/C ZINC, PATCH	1
3	237-6378-00P	#6-32 X 3/8 PAN PHILLIPS w/DOUBLE SEMS, PATCH	1
4	242-5001-00	#6 WASHER	2
5	254-5008-09	HEX SPACER - 1 1/2 "	2
6	545-7666-00	TOY, BARREL	1
7	830-8523-17	PLASTIC, JAWS PRE/LE -17	1

### 5.45 PLASTIC 18 ASSEMBLY

511-3097-18

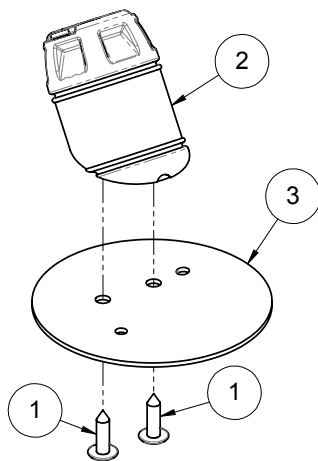

ID	Part Number	Description	Qty
1	237-5809-00	SCREW, #6 X 1/2" PTH A	2
2	545-7666-00	TOY BARREL	1
3	830-8523-18	PLASTIC, JAWS PRE/LE -18	1

### 5.46 PLASTIC 92 ASSEMBLY

511-3097-92

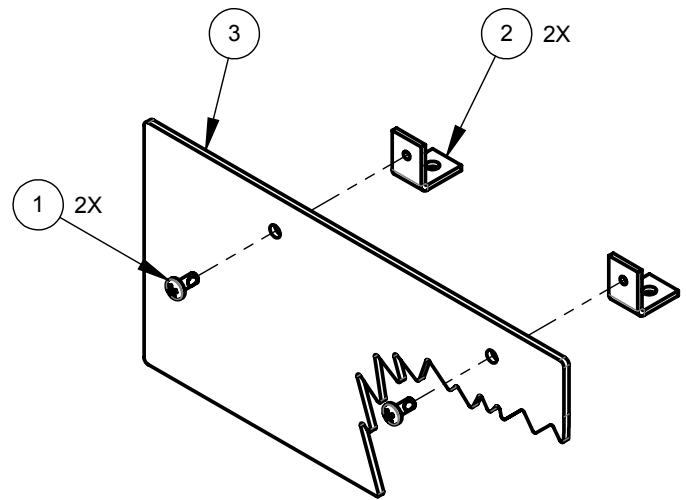

ID	Part Number	Description	Qty
1	237-6331-00P	SCREW, 4-40 X 1/4" PPH MS BLACK, PATCH	2
2	535-1305-00	BRACKET - PLASTIC MTG - 90°	2
3	830-8523-92	PLASTIC, JAWS PRE/LE -92	1

### 5.47 PLASTIC 94 ASSEMBLY

511-3097-94

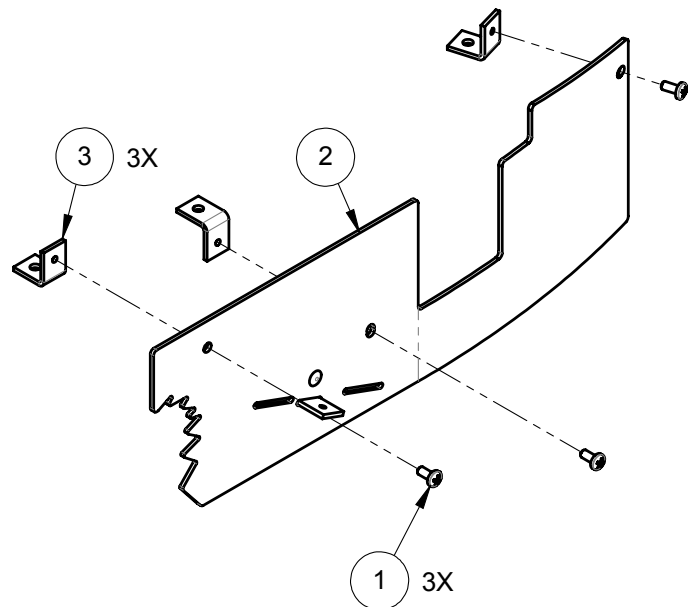

ID	Part Number	Description	Qty
1	237-6331-00P	SCREW, 4-40 X 1/4" PPH MS BLACK, PATCH	3
2	510-5819-94	RIVETED PLASTIC ASM, JAWS PRE/LE -94	1
3	535-1305-00	BRACKET - PLASTIC MTG - 90°	3

### 5.48 PLASTIC 96 ASSEMBLY

511-3097-96

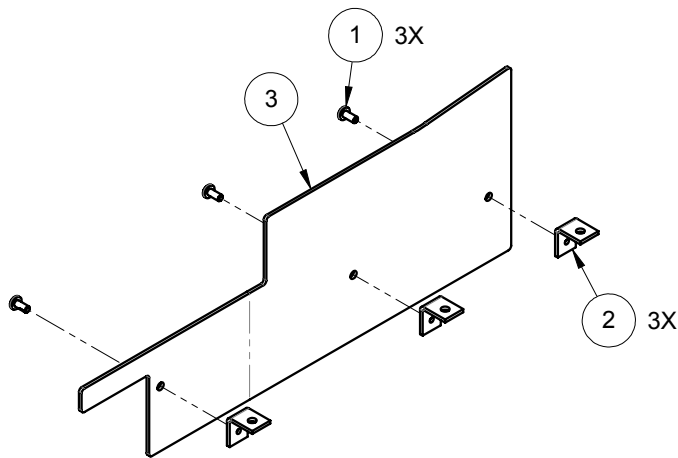

ID	Part Number	Description	Qty
1	237-6331-00P	SCREW, 4-40 X 1/4" PPH MS BLACK, PATCH	3
2	535-1305-00	BRACKET - PLASTIC MTG - 90°	3
3	830-8523-96	PLASTIC, JAWS PRE/LE -96	1

### 5.50 PLASTIC 98 ASSEMBLY

511-3097-98

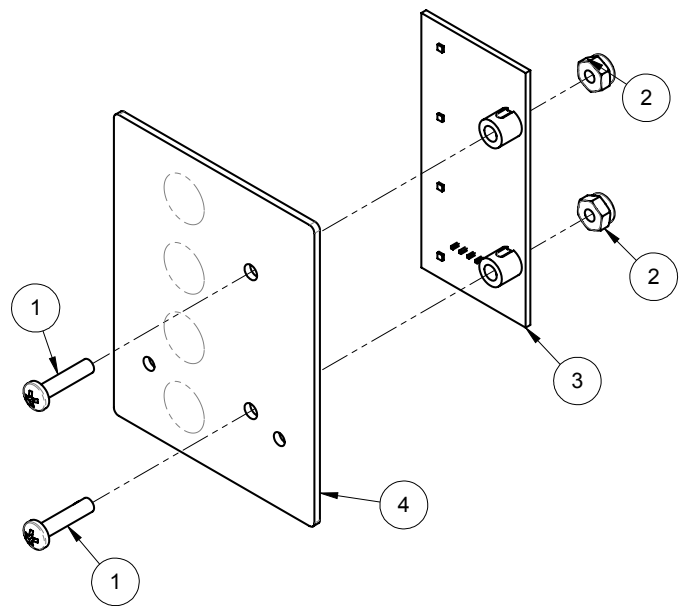

ID	Part Number	Description	Qty
1	237-5503-01P	SCREW, 6-32 X 5/8" PPH MS BLACK, PATCH	2
2	240-5005-00	6-32 NYLON STOP NUT	2
3	520-1076-00	PCA BILL-BRD MINI-PLYFLD 4-LED	1
4	830-8523-98	PLASTIC, JAWS PRE/LE -98	1

### 5.49 PLASTIC 97 ASSEMBLY

511-3097-97

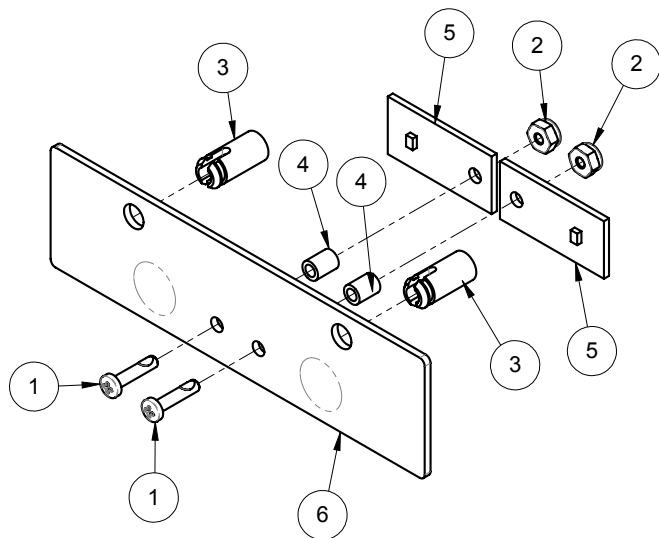

ID	Part Number	Description	Qty
1	237-5816-01P	SCREW, 4-40 X 1/2" PPH BLACK, PATCH	2
2	240-5303-00	4-40 NYLON LOCK NUT	2
3	254-5007-04	1/2" SELF RETAINING SPACER	2
4	254-5090-02	PLASTIC SPACER #4 SCREW, 3/16" OD - 1/4" LENGTH	2
5	520-5307-00	SINGLE LED PCB	2
6	830-8523-97	PLASTIC, JAWS PRE/LE -97	1



### 5.51 BALL GUIDE 01 ASSEMBLY 511-3072-01

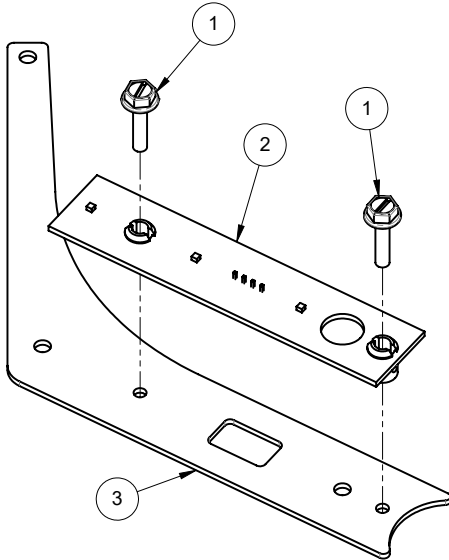

ID	Part Number	Description	Qty
1	237-5976-04	SCREW, 6-32 X 5/8" HWH SWAGE, SER-RATED	2
2	520-8531-00	PCA INLANE 3W LED BOARD	1
3	535-2837-01	BALL GUIDE -01, JAWS	1

### 5.52 BALL GUIDE 02 ASSEMBLY 511-3072-02

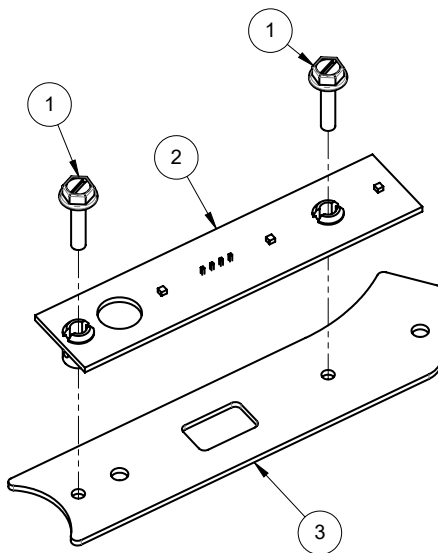

ID	Part Number	Description	Qty
1	237-5976-04	SCREW, 6-32 X 5/8" HWH SWAGE, SERRATED	2
2	520-8531-00	PCA INLANE 3W LED BOARD	1
3	535-2837-02	BALL GUIDE -02, JAWS	1

### 5.53 BALL GUIDE 03 ASSEMBLY 511-3072-03

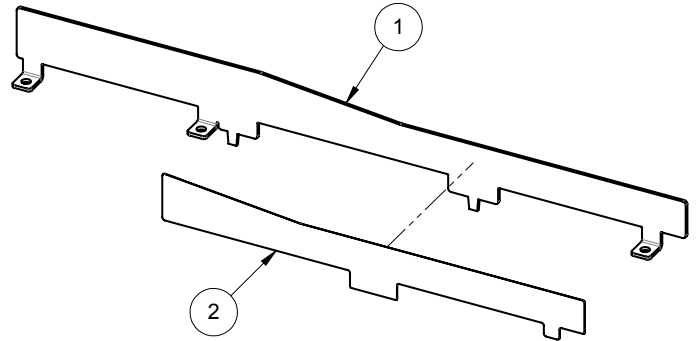

ID	Part Number	Description	Qty
1	535-2837-03	BALL GUIDE, JAWS PRE/LE -03	1
2	820-1436-67	DECAL, JAWS PRE/LE -67	1

### 5.54 BALL GUIDE 56 ASSEMBLY 511-3072-56

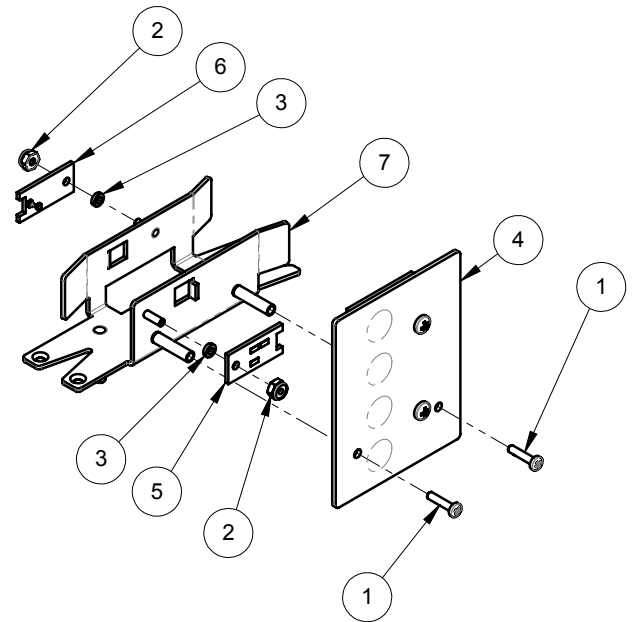

ID	Part Number	Description	Qty
1	237-5816-01P	SCREW, 4-40 X 1/2" PPH BLACK, PATCH	2
2	240-5303-00	4-40 NYLON LOCK NUT	2
3	242-5092-00	NYLON WASHER .109" X .210" X .052"	2
4	511-3097-98	PLASTIC ASM, JAWS PRE/LE -98	1
5	520-8115-00	PCB, IR OPTO EMITTER, ANTI-ROTATION	1
6	520-8116-00	PCB, IR OPTO RECEIVER, ANTI-ROTATION	1
7	535-2837-56	BALL GUIDE, JAWS PRE/LE -56	1

## PARTS REFERENCE

### 5.55 LEFT SIDE RAIL ASSEMBLY

511-8955-00

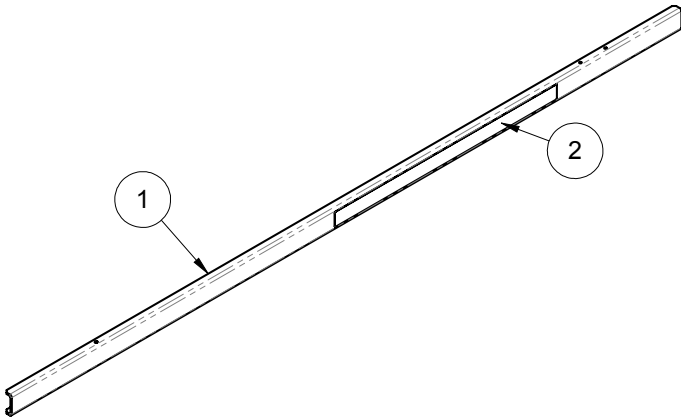

ID	Part Number	Description	Qty
1	535-1362-00	STEEL RAIL - BLANK	1
2	820-8634-00	DECAL, JAWS SIDE RAIL	1

### 5.57 RIGHT RAMP ASSEMBLY

500-2635-00

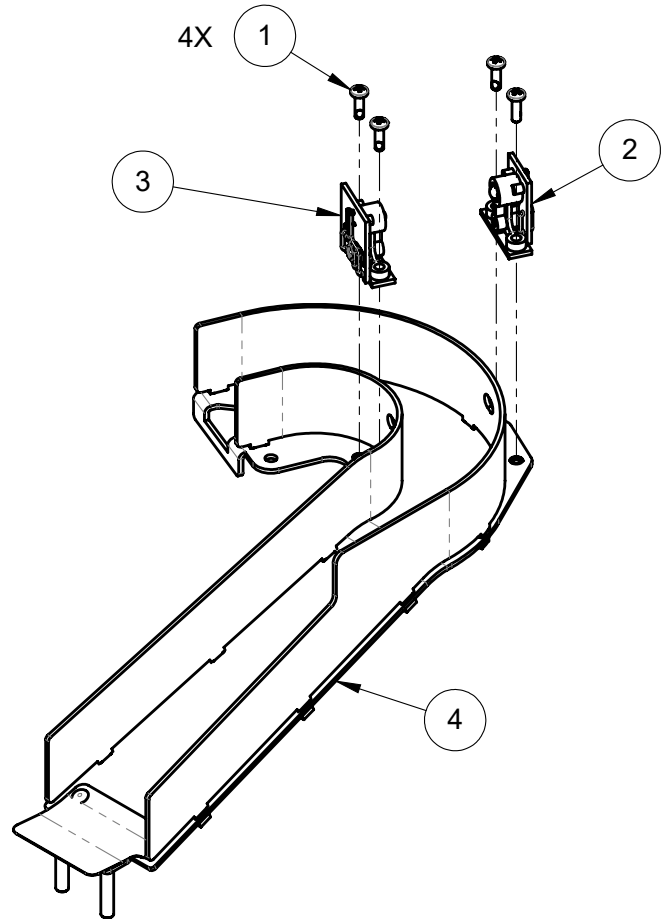

ID	Part Number	Description	Qty
1	237-5997-00P	SCREW, 4-40 X 3/8" PPH MS BLACK, PATCH	4
2	515-0215-00	LONG RANGE OPTO EMITTER ASSEMBLY	1
3	515-0215-01	LONG RANGE OPTO RECEIVER ASSEMBLY	1
4	510-7949-00	RIVETED RIGHT RAMP, JAWS	1

### 5.56 DUMP RAMP ASSEMBLY

511-5335-00

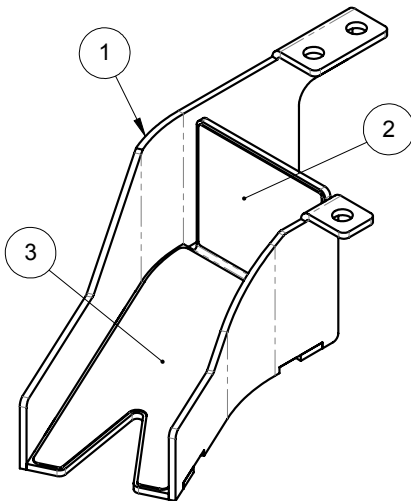

ID	Part Number	Description	Qty
1	515-2829-00	DUMP RAMP, JAWS PRE/LE	1
2	820-1436-73	DECAL, JAWS PRE/LE -73	1
3	820-1436-74	DECAL, JAWS PRE/LE -74	1

### 5.58 UPPER RAMP ASSEMBLY

511-4082-00

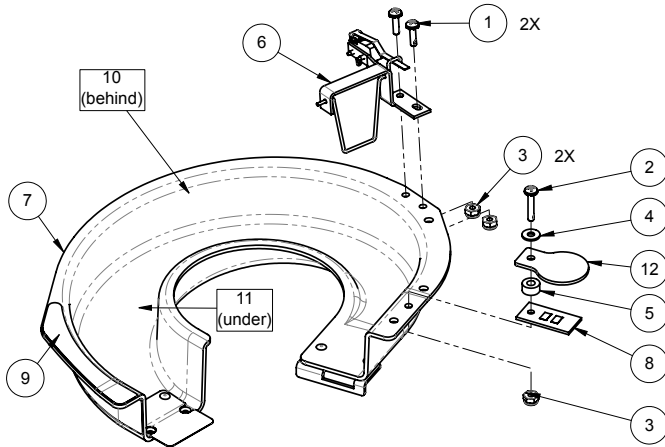

ID	Part Number	Description	Qty
1	232-5202-00P	SCREW, 6-32 X 1/2" PPH MS SEMS, PATCH	2
2	232-5204-00P	SCREW, 6-32 X 3/4" PPH MS SEMS, PATCH	1
3	240-5005-00	6-32 NYLON STOP NUT	3
4	242-5001-00	#6 WASHER	1
5	254-5000-18	NYLON SPACER - BLACK - 3/8 OD X .175 ID X 3/16"	1
6	500-9936-01	SWITCH GATE ASSEMBLY	1
7	510-1082-00	RIVETED ASM, JAWS PRE/LE UPPER RAMP	1
8	520-7000-00	SINGLE FLASH LED BOARD	1
9	820-1436-77	DECAL, JAWS PRE/LE, -77	1
10	820-8631-01	DECAL, JAWS PRE/LE RAMP, -01	1
11	820-8631-02	DECAL, JAWS PRE/LE RAMP, -02	1
12	830-8523-88	PLASTIC, JAWS PRE/LE, -88	1

### 5.59 LEFT RAMP ASSEMBLY

511-5401-00

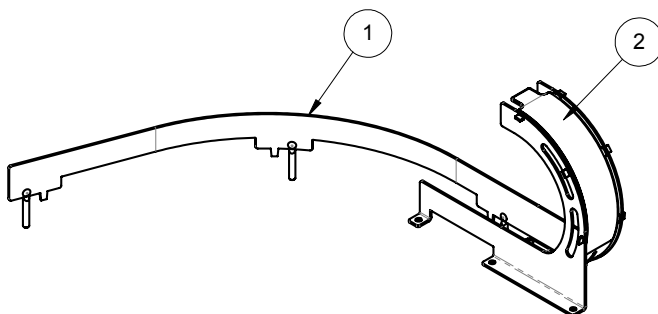

ID	Part Number	Description	Qty
1	515-2799-00	LEFT METAL RAMP, JAWS PRE/LE	1
2	820-1436-76	DECAL, JAWS PRE/LE -76	1

### 5.60 SWITCH GATE ASSEMBLY

500-9936-01

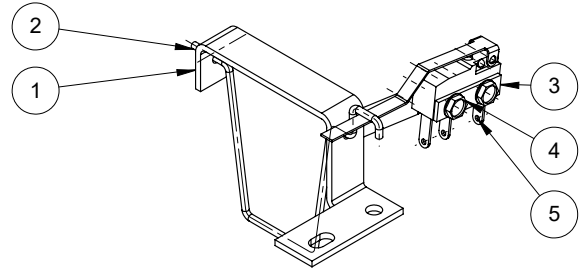

ID	Part Number	Description	Qty
1	535-7756-01	BRACKET - GATE	1
2	535-7755-01	WIRE FORM	1
3	535-6539-00	SWITCH BODY PROTECT PLATE	1
4	237-5937-02	SCREW, 2-56 X 1/2" HWH MS	2
5	180-5087-00	SWITCH GATE	1

### 5.61 CENTER RAMP ROLLUNDER SWITCH GATE ASSEMBLY

511-4093-01

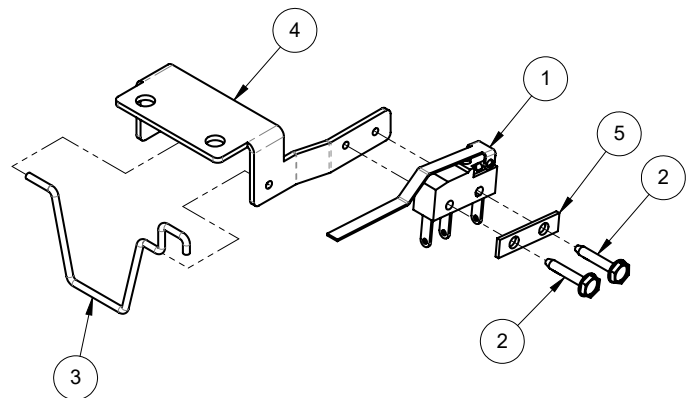

ID	Part Number	Description	Qty
1	180-5087-00	SWITCH - GATE	1
2	237-5937-02P	SCREW, 2-56 X 1/2" HWH MS, PATCH	2
3	535-2057-00	WIRE, ROLLUNDER GATE, BG MNT	1
4	535-2861-02	BRACKET, ROLLUNDER, TOP MOUNT	1
5	535-6539-00	SWITCH BODY PROTECT PLATE	1



# 5.62 UPPER PLAYFIELD ASSEMBLY

500-2646-00

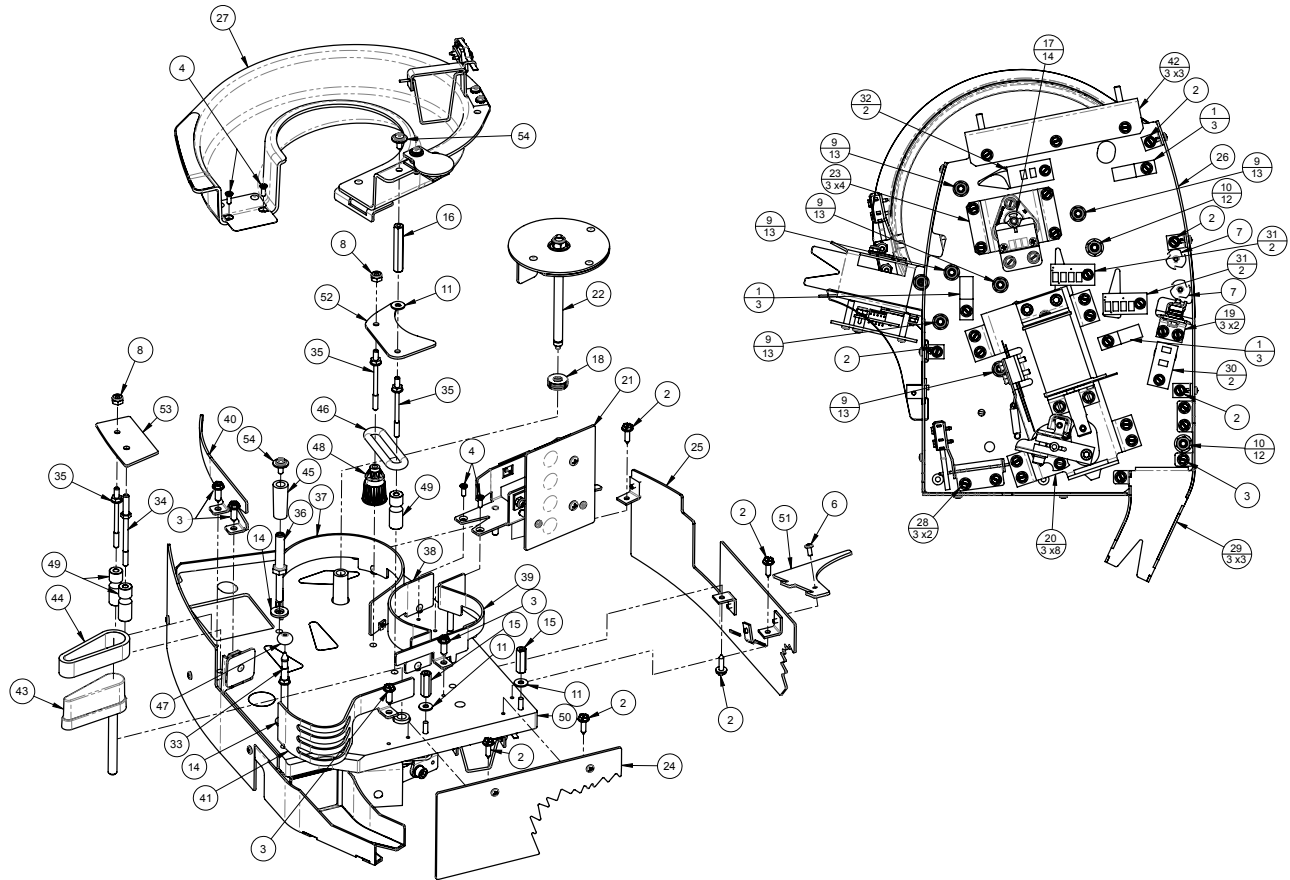

ID	Part Number	Description	Qty
1	040-5000-06	1/2" CABLE CLAMP	3
2	234-5001-02	SCREW, #6 X 1/2" HWH	12
3	234-5101-00	SCREW, #8 X 1/2" SLT HWH AB ZINC	30
4	237-5830-00	SCREW, #4 X 3/8" PFH AB	4
5	237-5921-04	FIN SHANK SCREW - 7/8" LG.	2
6	237-6331-00	SCREW, 4-40 X 1/4" PPH MS BLACK	1
7	240-5002-00	6-32 T-NUT	4
8	240-5005-00	6-32 NYLON STOP NUT	2
9	240-5102-00	8-32 NYLON LOCK NUT	7
10	240-5203-00	10-32 NYLON LOCK NUT	2
11	242-5001-00	#6 WASHER	3
12	242-5003-00	#10 FLAT WASHER - 1/2" O.D. X .062 THICK	2
13	242-5005-00	#8 WASHER	7
14	242-5008-00	WASHER, 1/4" ID X 1/2" OD X 1/16" THICK	3
15	254-5008-04	HEX SPACER - 3/4 "	2
16	254-5008-09	HEX SPACER - 1 1/2 "	1
17	270-5002-00	RETAINING RING - 1/4"	1
18	283-5019-00	3-PIECE THRUST BEARING, 1/4" SHAFT	1
19	500-1048-00-00	1" SQ. S/U TARGET ASSY - ANTI SWAY - 2 LUG - Black	1
20	500-6543-42-ND	FLIPPER ASSEMBLY, 22-1080 COIL, RIGHT	1
21	511-3072-56	BALL GUIDE ASM, JAWS PRE/LE -56	1
22	511-3073-00	ASM, SPINNER, SHIP WHEEL	1
23	511-3074-00	ASM, HORIZONTAL SPINNER, LOWER	1
24	511-3097-92	PLASTIC ASM, JAWS PRE/LE -92	1
25	511-3097-94	PLASTIC ASM, JAWS PRE/LE -94	1
26	511-3097-96	PLASTIC ASM, JAWS PRE/LE -96	1
27	511-4082-00	ASM, JAWS PRE/LE UPPER RAMP	1

28	511-4093-01	ASM, ROLLUNDER GATE, TOP MOUNT	1
29	511-5335-00	ASM, DUMP RAMP W/ DECALS	1
30	520-5307-00	SINGLE LED PCB	1
31	520-5333-00	SINGLE RGB BOARD	2
32	520-7000-00	SINGLE FLASH LED BOARD	1
33	530-5005-00	MINI-POST (MACHINE THREAD)	1
34	530-5008-00	6-32 POST W/ 8-32 X 1/2" MALE THD	1
35	530-5012-02	6-32 POST SCREW	3
36	530-5332-01	HEX BUMPER POST	1
37	535-2837-51	BALL GUIDE, JAWS PRE/LE -51	1
38	535-2837-52	BALL GUIDE, JAWS PRE/LE -52	1
39	535-2837-53	BALL GUIDE, JAWS PRE/LE -53	1
40	535-2837-54	BALL GUIDE, JAWS PRE/LE -54	1
41	535-2837-55	BALL GUIDE, JAWS PRE/LE -55	1
42	535-2842-00	BRACKET, UPPER PLAYFIELD SUPPORT, JAWS PRE/LE	1
43	544-2001-09-06	SMALL FLIPPER	1
44	545-5207-00	MINI - FLIPPER RUBBER	1
45	545-5308-00	POST - RUBBER - 3/8 O.D. X 1-1/16 - 95 A - BLACK	1
46	545-5348-05	1" I.D. RUBBER RING - BLACK	1
47	545-5348-17	7/16 O.D. RUBBER RING - BLACK	1
48	550-5034-XX	POST, GROOVED JEWEL, PLASTIC	1
49	550-5059-01	PLASTIC POST - CLEAR	3
50	830-71V6-XX	PLAYFIELD, JAWS PRE/LE UPPER	1
51	830-8523-72	PLASTIC, JAWS PRE/LE -72	1
52	830-8523-93	PLASTIC, JAWS PRE/LE -93	1
53	830-8523-95	PLASTIC, JAWS PRE/LE -95	1
54	237-6378-00P	#6-32 X 3/8 PAN PHILLIPS W/DOUBLE SEMS, PATCH	2

## 5.63 SHIP WHEEL SPINNER ASSEMBLY

511-3073-00

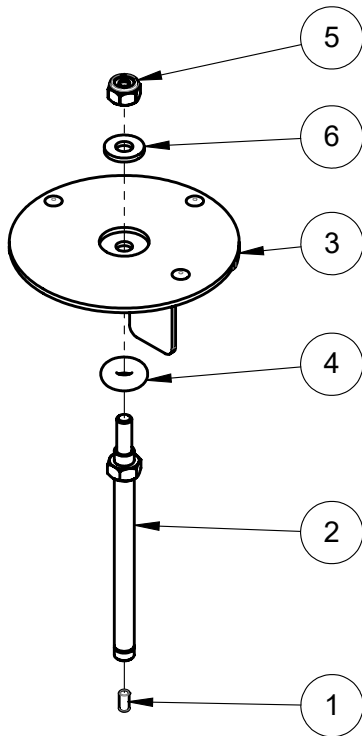

ID	Part Number	Description	Qty
1	090-5096-00	MAGNET, 1/8 X .250", DIAM. MAGNETIZED	1
2	530-2738-00	SHAFT, SHIP WHEEL SPINNER	1
3	510-1088-00	RIVETED ASM, SHIP WHEEL SPINNER	1
4	545-5348-01	RUBBER RING, BLACK, 3/16" ID	1
5	240-5203-00	10-32 NYLON LOCK NUT	1
6	242-5003-00	#10 FLAT WASHER - 1/2" O.D. X .062 THICK	1

## 5.64 BACK PANEL ASSEMBLY

500-2642-00

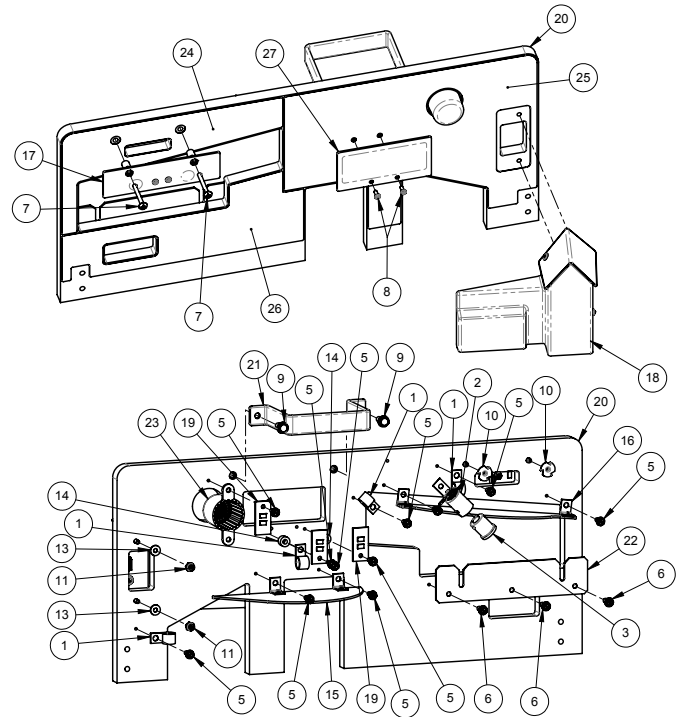

ID	Part Number	Description	Qty
1	040-5016-00B	CABLE CLAMP 0.38 BLACK	4
2	077-5100-00	LAYDOWN STANDARD SOCKET	1
3	113-5045-08	MULTI-LED FLASHER, 5 VDC - WHITE	1
4	234-5000-00	SCREW, #6 X 3/8" HWH	1
5	234-5001-02	SCREW, #6 X 1/2" HWH	11
6	234-5101-00	SCREW, #8 X 1/2" SLT HWH AB ZINC	3
7	237-5015-00P	6-32 x 1.25" PTH MS ZINC, PATCH	2
8	237-5815-00	SCREW, #4 X 3/8" PPH AB	2
9	237-5995-00	SCREW, 10-32 X 1/2" HWH SERR MS ZI	2
10	240-5002-00	6-32 T-NUT	2
11	240-5005-00	6-32 NYLON STOP NUT	2
12	240-5204-00	#10-32 T-NUT	2
13	242-5001-00	#6 WASHER	2
14	254-5000-09	NYLON SPACER - BLACK - 3/8 OD X .175 ID X 1/4"	2
15	510-5818-00	RIVETED PLASTIC ASM, JAWS, RIGHT RAMP COVER	1
16	510-5819-00	RIVETED PLASTIC ASM, JAWS, UPPER RAMP COVER	1
17	511-3097-97	PLASTIC ASM, JAWS -97	1
18	511-5400-00	ASM, QUINT'S SHACK	1
19	520-7000-00	SINGLE FLASH LED BOARD	3
20	525-9765-00	BACKPANEL, JAWS LE	1
21	535-2288-00	HANDLE, BACKPANEL	1
22	535-2842-01	BRACKET, UPPER PF MOUNT, BACKPANEL	1
23	550-5031-06	MINI MARS W/ EARS - YELLOW SB	1
24	820-1436-80	DECAL, JAWS -80	1
25	820-1436-81	DECAL, JAWS -81	1
26	820-1436-82	DECAL, JAWS -82	1
27	830-8523-99	PLASTIC, JAWS -99	1



# 6. SPECIFICATIONS

500-55V6-01

## SPECIFICATIONS, MECHANICAL, GAME SETUP

Specification	Imperial	Metric
Weight	210 lbs	96 kg
Max dimensions, leg levers extended (h, w, d)	78 x 27.75 x 57 in	198 x 70.5 x 145 cm
Minimum game dimensions (h, w, d)	76 x 27.75 x 57 in	193 x 70.5 x 145 cm
Minimum room dimensions per game (h, w, d)	80 x 36 x 84 in	203 x 91 cm x 214 cm

• (h, w, d) = height, width, depth.

## SPECIFICATIONS, MECHANICAL, BOXED

Specification	Imperial	Metric
Weight, boxed (without pallet)	230 lbs	105 kg
Box dimensions (h, w, d)	56.5 x 31 x 31 in	144 x 79 x 79 cm
Minimum dimensions (h, w, d)	76 x 26 x 57 in	193 x 66 x 145 cm

• (h, w, d) = height, width, depth.

## SPECIFICATIONS, ELECTRICAL

Specification	North America - 120VAC	International - 240VAC
Line Voltage, Nominal	120 VAC	240 VAC
Line Voltage Range	90 VAC - 250 VAC	90 VAC - 250 VAC
Line Frequency *	60 Hz	50 Hz, 60 Hz
Line Power, Current - attract mode	70 W, 0.6 A @ 120 VAC	70 W, 0.3 A @ 240 VAC
Line Power, Current - nominal	360 W, 3 A @ 120 VAC	360 W, 1.5 A @ 240 VAC
Line Power, Current - peak, <100 ms	540 W, 4.5 A @ 120 VAC	540 W, 2.25 A @ 240 VAC

\* NOTE: Games designed for 60hz operation (e.g. North America games) will not function correctly on 50hz power and vice versa.

**WARNING:** Overloading electrical supply circuits is dangerous. Do not overload circuits. To calculate the maximum number of games for a circuit, check circuit amperage rating and divide by the game Nominal Line Power Current rating for your line voltage. For example, a 15A 120V household circuit, 15/3 A (nominal current) = 5 games maximum.

## SPECIFICATIONS, ENVIRONMENT

	Minimum	Maximum
Temperature, Operating	32 °F / 0 °C	104°F / 40 °C
Temperature, Storage	32 °F / 0 °C	104°F / 40 °C
Relative Humidity, Operating	5%	95% non-condensing
Relative Humidity, Storage	5%	95% non-condensing

- (a) "The appliance has to be placed in a horizontal position."
- (b) If the supply cord is damaged, it must be replaced by the manufacturer, its service agent or similarly qualified person in order to avoid hazard.

### 6.1 GAME DIMENSIONS

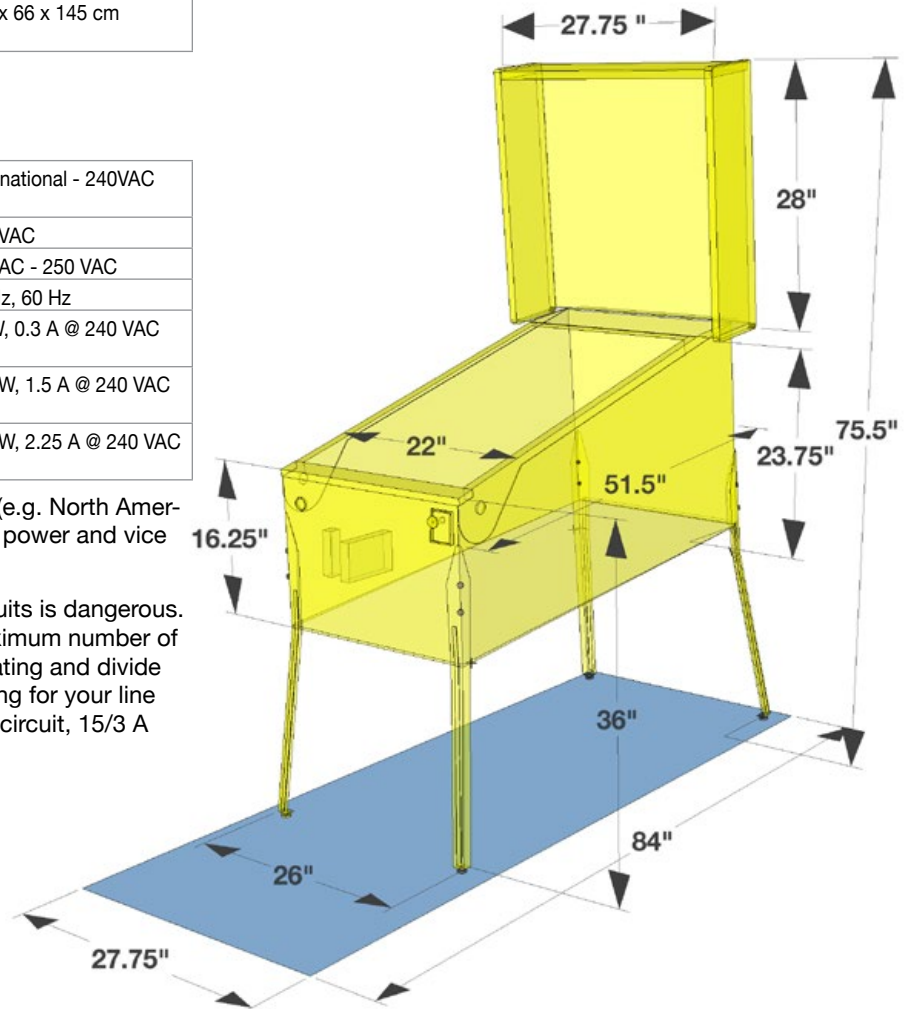

## 6.2 WARRANTY

500-55V6-01

Stern Pinball machines are assembled in Elk Grove Village, Illinois, USA; each pinball machine has unique characteristics that make it a one-of-a-kind American-made product. Each machine will have variations in appearance resulting from differences in the machine's particular wood parts, individual silk screened art and mechanical assemblies. Stern Pinball has inspected each game element to ensure it meets stringent quality and playability standards.

### STERN PINBALL INC LIMITED WARRANTY

Stern Pinball Inc ("SELLER") warrants only to the initial purchaser of its products that the items listed below are free from defects in material and workmanship under normal use and service for the warranty period specified:

- Printed circuit boards (game logic): 2 months
- Dot Matrix / LCD Display: 9 months

No other parts of seller's product are warranted.

Warranty periods are effective from the initial date of shipment from seller to its authorized distributors.

Seller's sole liability shall be, at its option, to repair or replace products which are returned to seller during the warranty periods specified, provided:

1. Seller is notified promptly upon discovery by purchaser that stated products are defective.
2. Such products are properly packaged and then returned freight prepaid, to seller's plant.

This warranty does not apply to any parts damaged during shipment and/or due to improper handling, or due to improper installation or usage, or alteration. In no event shall the seller be liable for any anticipated profits, loss of profits, loss of use, accidental or consequential damages, or any other losses incurred by the customer in connection with the purchase of a Stern Pinball Inc Product.

### WARRANTY DISCLAIMER

Except as specifically provided in a written contract between seller and purchaser, there are no other warranties, express or implied, including any implied warranties of merchantability or fitness for a particular purpose.

This Game Service Manual and all other documents relating to this product, playfield components, features, rules, programming, and operation are subject to change without notice (Service Bulletins, if applicable, available through official Stern Pinball website).

## ATTENTION! IMPORTANT WARRANTY INFORMATION

**The electronics system, node network architecture, mechanical devices and associated software control systems in this pinball machine are designed to work with genuine Stern Pinball accessories and devices.**

**Installation of non-authorized accessories, lamps, LED's, motors or other devices or modification of electro-mechanical devices may damage the system and will void your warranty.**

## 6.3 WARNINGS, COMPLIANCE, AND LEGAL NOTICES

### PHOTOSENSITIVE SEIZURES HEALTH WARNING



A very small percentage of people may experience a seizure when exposed to certain visual images, including flashing lights or patterns. Even people with no history of seizures of epilepsy may have an undiagnosed condition that can cause "photosensitive epileptic seizures" due to certain visual images, flashing lights or patterns. Symptoms can include lightheadedness, altered vision, eye or face twitching, jerking or shaking of arms or legs, disorientation, confusion, momentary loss of awareness, and loss of consciousness or convulsions that can lead to injury from falling down or striking nearby objects.

IMMEDIATELY STOP PLAYING AND CONSULT A DOCTOR IF YOU EXPERIENCE ANY OF THESE SYMPTOMS.

### PARTS SUBSTITUTIONS



For safety and reliability, substitute parts and equipment modifications are not recommended and may void any and all warranties. Use of Non-Stern Pinball Inc Parts or Modifications of game circuitry may adversely affect game play or game safety. Transport pinball machines with hinged backbox in the down position only! Always take great care when servicing any game. Always read the service manual before replacing or servicing components. Substitutions of parts or equipment modifications may void FCC type acceptance.

Always disconnect the line voltage before servicing. Some parts may remain energized when unplugged. Take great caution when servicing any electrical components.

**PERCHLORATE MATERIAL** - Special handling may apply. See [www.dtsc.ca.gov/hazardouswaste/perchlorate](http://www.dtsc.ca.gov/hazardouswaste/perchlorate)

### FCC CLASS A SUBPART J COMPLIANCE



This equipment has been tested and found to comply with the limits for a Class A digital device, pursuant to part 15 of the FCC Rules. These limits are designed to provide reasonable protection against harmful interference when the equipment is operated in a commercial environment. This equipment generates, uses, and can radiate radio frequency energy and, if not installed and used in accordance with the instruction manual, may cause harmful interference to radio communications. Operation of this equipment in a residential area is likely to cause harmful interference in which case the user will be required to correct the interference at his own expense.

### RF INTERFERENCE NOTICE

The cable harness placements, ground strap routing, and other shielding have been designed to keep RF radiation and conduction within levels accepted by FCC rules. To maintain these levels, factory harness position, shielding, and ground straps must be installed in their factory locations should they become disconnected during maintenance.

### COPYRIGHT AND INTELLECTUAL PROPERTY NOTICE

This document and the data disclosed herein or herewith is not to be reproduced (Except where noted), used, or otherwise disclosed in whole or in part to anyone without written consent of Stern Pinball Inc.

Products in this manual, the company name and devices and the design of the manual itself are protected by federal patents (and patents pending), design registrations, trademarks, and copyrights. Action will be taken in the event of infringement or imitation. The right is reserved to change specifications without prior notice.



### 6.4 STERN PINBALL END USER LICENSE AGREEMENT

This limited software license Agreement (“Agreement”) applies to your use of Stern Pinball Software pre-installed on a Stern Pinball Machine and any Authorized Updates made available to you.

**BY USING YOUR STERN PINBALL MACHINE, YOU AGREE TO THE TERMS OF THIS AGREEMENT.** If you do not agree to the terms of this Agreement, do not use your Stern Pinball Machine or any Authorized Updates. Please read this entire Agreement, which governs your use of the Stern Pinball Machine, Stern Pinball Software and all Authorized Updates.

#### ADULT CONSENT

TO ENTER INTO THIS AGREEMENT, YOU MUST BE AN ADULT OF THE LEGAL AGE OF MAJORITY IN YOUR COUNTRY OF RESIDENCE. YOU ARE LEGALLY AND FINANCIALLY RESPONSIBLE FOR ALL ACTIONS USING YOUR STERN PINBALL MACHINE AND SOFTWARE AND ACCESSING OR USING ANY ONLINE GAMING PLATFORM, INCLUDING THE ACTIONS OF ANYONE YOU ALLOW TO USE AND ACCESS TO YOUR MACHINE AND ANY ASSOCIATED ACCOUNT. YOU AFFIRM THAT YOU HAVE REACHED THE LEGAL AGE OF MAJORITY, UNDERSTAND AND ACCEPT THIS AGREEMENT. IF YOU ARE UNDER THE LEGAL AGE OF MAJORITY, YOUR PARENT OR LEGAL GUARDIAN MUST CONSENT TO THIS AGREEMENT.

#### DEFINITIONS

- a. “Stern Pinball Machine” means a Stern Pinball arcade game machine.
- b. “Stern Pinball Software” means software (including but not limited to firmware) pre-installed in the Stern Pinball Machine, including all Authorized Content and any Authorized Updates that Stern Pinball may make available to You from time to time.
- c. “Authorized Content” means all Stern Pinball and third-party owned software and content incorporated into or used with the Stern Pinball Software or otherwise embedded in or utilized by a Stern Pinball Machine, including but not limited to graphics, images, music, vocals and voices.
- d. “Authorized Update” means an update to the Stern Pinball Software distributed by Stern Pinball or otherwise made available by Stern Pinball, including for download on its website.
- e. “Unauthorized Content” means all content, including but not limited to graphics, images, music, vocals and voices, that does not comprise Authorized Content or an Authorized Update.
- f. “Unauthorized Software” means any software (including but not limited to firmware) not pre-installed by Stern Pinball on a Stern Pinball Machine or that does not comprise Authorized Content or Authorized Update.
- g. “You” means the purchaser or current owner of a Stern Pinball Machine.

#### LICENSE

Stern Pinball hereby grants You a nonexclusive, non-transferable, limited, and revocable right and license to use one copy of the Stern Pinball Software and Authorized Content and any Authorized Update solely for your personal use, or that of your patrons and customers if you are a commercial entity, for playing a single Stern Pinball Machine. The Stern Pinball Software, Authorized Content and Authorized Updates are licensed, not sold, to You, and no ownership rights are transferred by this Agreement. The Stern Pinball Software Authorized Content and Authorized Updates are protected by U.S. and international copyright. All rights not explicitly granted to you in this Agreement are reserved by Stern Pinball.

- a. As a condition to this Stern Pinball Software license, You agree that:
  - i. You will not copy, reproduce, alter, replace, distribute, reverse engineer, decompile, disassemble, display, perform, create derivative works based on, or otherwise modify the Stern Pinball hardware or Stern Pinball Software or any Authorized Update, in whole or in part; and will not commercially exploit any of the foregoing.
  - ii. **You will not use or install any Unauthorized Content or Unauthorized Software. Use of Unauthorized Content or Unauthorized Software may result in your Stern Pinball Machine ceasing to work permanently and/or losing access to Stern Pinball’s online game network, either immediately or after a later installed Authorized Update.**



- iii. **You will not create, develop, distribute or assist anyone else in creating, developing or distributing any Unauthorized Content or Unauthorized Software intended for use with a Stern Pinball Machine, whether to add to or modify the gameplay, any audio content (whether music, sound or voice), or any video content of any Stern Pinball Machine, or to gain advantage in any online or other game modes, or otherwise.**
- iv. You will not share any Stern Pinball Software, Authorized Content or Authorized Update with any other person or company and will not permit anyone else to access or copy any Stern Pinball Software or Authorized Content or Authorized Update installed on your Machine for any purpose.
- v. In view of the rights held by third-party owners of Authorized Content (e.g., music and video clips), Stern does not have the legal authority to give permission to stream the gameplay of Stern Pinball Machines.
- vi. You will not attempt to defeat or circumvent any anti-piracy, security, and/or technical measures to control access to the Stern Pinball Software, features, functions or content, prevent unauthorized use, or otherwise prevent anyone from exceeding the limited license rights granted under this Agreement, "Security Measures". Attempting to defeat or circumvent any Security Measure may result in your Stern Pinball Machine ceasing to work permanently either immediately or after a later installed Authorized Update.
- vii. **Stern Pinball may update the Stern Pinball Software from time to time without further notice to You, for example, to update any anti-piracy, security, and technical measure.**

## PRIVACY POLICY

Your use of the Stern Pinball Machine, Stern Pinball Software and any Authorized Updates is subject to Stern Pinball's Privacy Policy which can be found at <https://sternpinball.com/privacy-policy>.

## WARRANTY

EXCEPT AS PROVIDED HEREIN, THE STERN PINBALL SOFTWARE, AUTHORIZED CONTENT AND AUTHORIZED UPDATES ARE PROVIDED "AS IS" AND, TO THE MAXIMUM EXTENT ALLOWABLE UNDER LAW, STERN PINBALL DISCLAIMS ALL WARRANTIES OF ANY KIND, WHETHER EXPRESS OR IMPLIED, INCLUDING BUT NOT LIMITED TO ANY WARRANTIES OF MERCHANTABILITY, FITNESS FOR A PARTICULAR PURPOSE, AND NONINFRINGEMENT. WITHOUT LIMITING THE FOREGOING, STERN PINBALL DOES NOT WARRANT THAT OPERATION OF THE STERN PINBALL MACHINE OR ANY ONLINE OR CONNECTED GAME NETWORK WILL BE UNINTERRUPTED OR ERROR-FREE.

## EXCLUSION OF CERTAIN DAMAGES

STERN PINBALL IS NOT RESPONSIBLE FOR ANY DIRECT, INDIRECT, INCIDENTAL, SPECIAL, OR CONSEQUENTIAL DAMAGES; ANY LOSS OF DATA, PRIVACY, CONFIDENTIALITY, OR PROFITS; OR ANY INABILITY TO USE THE STERN PINBALL MACHINE, STERN PINBALL SOFTWARE OR ANY AUTHORIZED UPDATE. THESE EXCLUSIONS APPLY EVEN IF STERN PINBALL HAS BEEN ADVISED OF THE POSSIBILITY OF THESE DAMAGES, AND EVEN IF ANY REMEDY FAILS OF ITS ESSENTIAL PURPOSE. Some countries do not allow the exclusion or limitation of incidental or consequential damages, so this limitation or exclusion may not apply to You.

These terms apply to the maximum extent permitted by law and unless prohibited by law. These terms do not change your rights under the laws of your country if those laws do not permit that change.

## TERRITORY AND CHOICE OF LAW

This License is valid only in the country in which you purchased your Stern Pinball Machine. This License will be subject to and construed in accordance with the laws of the State of Illinois, U.S.A., regardless of conflict of laws principles. You agree to submit to the exclusive jurisdiction of the state and federal courts in Cook County, Illinois, U.S.A. for the resolution of any dispute regarding this Agreement or the subject matter of this Agreement and to waive any jurisdictional, venue, or inconvenient forum objections to such courts.

This Agreement may be updated by Stern Pinball from time to time with the current version posted at [www.sternpinball.com/EULA](http://www.sternpinball.com/EULA). Your continued use of the Stern Pinball Software and Authorized Update after an updated Agreement has been posted constitutes your acceptance of all of its terms.





**1-800-KICKERS**  
**PARTS.SERVICE@STERNPINBALL.COM**  
**WWW.STERNPINBALL.COM**  
**FACEBOOK.COM/STERNPINBALL**

JAWS LE #500-55V6-01  
JAWS PREMIUM #500-55V7-01  
MANUAL #780-50V6-00

