



STERN Pinball Inc.

Kit # 502-8061-00
METALLICA REMASTERED: BUTY #25
REPLACEMENT KIT

Installation Instructions

Document Number: 755-8044-00

Issue: Rev 1.1

Date: December 16, 2024

This instruction sheet is provided as a guide for installation. The installation must be performed by a qualified service professional. It is the responsibility of the service person installing the kit to make sure it is installed properly and securely.

COPYRIGHT

Copyright STERN Pinball Inc. 2022

All rights reserved. No part of this publication
may be reproduced in any form or by any means
without the prior written permission of
Stern Pinball Inc.

Table of Contents

1.	Tools Required for Installation.....	Pg 2
2.	Bill of Materials.....	Pg 2
3.	Service Preparation.....	Pg 2
4.	Ramp Cover Replacement.....	Pg 3

1. Tools Required for Installation

- #2 Phillips Screwdriver
- ¼" Nut Driver

2. Bill of Materials

ITEM NO.	PART NO.	DESCRIPTION	QUANT.
1	232-5202-00P	SCREW, 6-32 X 1/2" PPH MS SEMS, PATCH	2
2	242-5001-00	#6 WASHER	2
3	830-8580-00	RAMP COVER SUPPORT, LEFT RAMP	1

3. Prepare game for servicing

Read all instructions carefully before attempting the installation.

3.1. Unplug game and position playfield to required service position

- 3.1.1. Make sure that the machine is turned off and unplugged before the installation begins. Remove the lockdown bar and playfield glass.
- 3.1.2. Raise the playfield to proper service position to access the ramp cover.

4. Ramp Cover Replacement

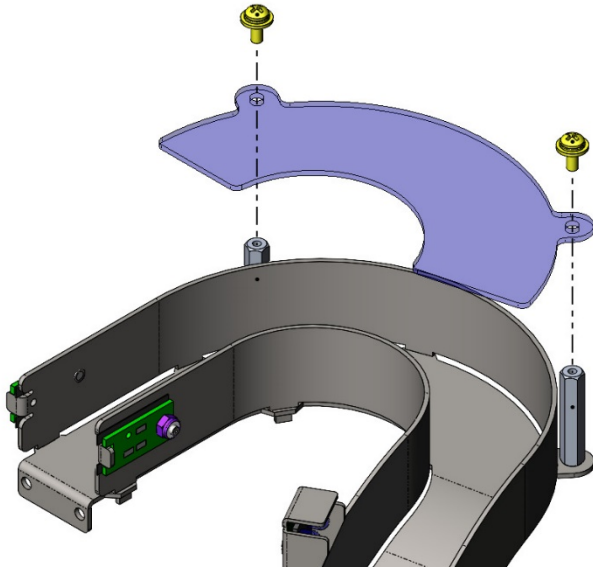

4.1. Remove and discard two screws.

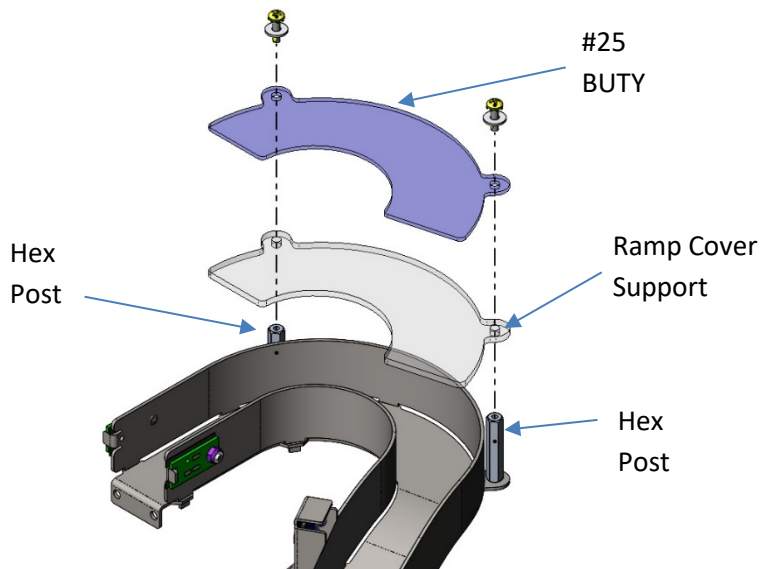

4.2. Re-tighten the hex posts with a $\frac{1}{4}$ " nut driver. Install thick clear RAMP COVER SUPPORT item 3 and arted BUTY #25 on top of the RAMP COVER SUPPORT. Secure the assembly with two #6 flat washers and two #6-32 x $\frac{1}{2}$ " Phillips Pan Head screws provided in kit. Tighten securely.