

# POKÉMON

## SERVICE AND OPERATION MANUAL



©2026 Pokémon. ©1995–2026 Nintendo / Creatures Inc. / GAME FREAK inc. TM, ®, and character names are trademarks of Nintendo.

### WARNING

**IMPORTANT HEALTH WARNING: PHOTOSENSITIVE SEIZURES** - A very small percentage of people may experience a seizure when exposed to certain visual images, including flashing lights or patterns. Even people with no history of seizures of epilepsy may have an undiagnosed condition that can cause "photosensitive epileptic seizures" due to certain visual images, flashing lights or patterns. Symptoms can include lightheadedness, altered vision, eye or face twitching, jerking or shaking of arms or legs, disorientation, confusion, momentary loss of awareness, and loss of consciousness or convulsions that can lead to injury from falling down or striking nearby objects.

IMMEDIATELY STOP PLAYING AND CONSULT A DOCTOR IF YOU EXPERIENCE ANY OF THESE SYMPTOMS.

### ATTENTION! IMPORTANT WARRANTY INFORMATION

The electronics system, node network architecture, mechanical devices and associated software control systems in this pinball machine are designed to work with genuine Stern Pinball accessories and devices.

Installation of non-authorized accessories, lamps, LED's, motors or other devices or modification of electro-mechanical devices may damage the system and may void your warranty.

Stern Pinball machines are assembled in Elk Grove Village, Illinois, USA. Stern Pinball has inspected each game element to ensure it meets our quality standards.

Each pinball machine has unique characteristics that make it a one-of-a-kind American made product. Each will have variations in appearance resulting from differences in the machine's particular wood parts, individual printed art and mechanical assemblies. No playfield is perfectly flat and varies depending on the season. Game play will result in playfield dimpling as the harder steel ball contacts the wood and coating; over time multiple dimples will blend to make them less noticeable. Normal plastic insert crazing (tiny stress cracks) and ghosting (small cloudy areas around insert edges) are often seen in pinball machines, due to a combination of plastic mold stress, pushing of inserts into purposely undersized holes, and heating and breaking of inserts' plastic "skin" when the playfield is sanded.

Games configured for North America operate on 60 cycle electricity only. These games will not operate in countries with 50 cycle electricity (Europe, UK, Australia).



MANUAL #780-50AJ-00  
POKÉMON LE #500-55AJ-01  
POKÉMON PREMIUM #500-55AH-01

1-800-KICKERS - [service@sternpinball.com](mailto:service@sternpinball.com)  
[www.sternpinball.com](http://www.sternpinball.com) - [facebook.com/sternpinball](https://facebook.com/sternpinball)

# TABLE OF CONTENTS

<b>1. Setup and Moving.....</b>	<b>3</b>	5.15 Slingshot Assembly.....	48
1.1 First-Time Setup Instructions.....	3	5.16 Flipper Assembly, Left.....	49
1.2 Service Menu Navigation.....	6	5.17 Flipper Assembly, Right.....	49
1.3 Game Pricing Reference Table.....	9	5.18 Pop Bumper Assembly.....	50
1.4 Transporting the Game.....	10	5.19 Bottom Arch Assembly.....	51
1.5 Maintenance.....	11	5.20 Jump Ramp Assembly.....	51
1.6 Maintenance Kits.....	11	5.21 Gate Assembly (Jump Ramp).....	51
1.7 Common Parts.....	11	5.22 Bonus Bowl Assembly.....	52
<b>2. SPIKE System and Node Guide.....</b>	<b>12</b>	5.23 Bowl Diverter Coil Assembly.....	52
2.1 SPIKE System Overview.....	12	5.24 Eject VUK Assembly.....	53
2.2 Node Bus Cabling.....	12	5.25 Subway VUK Assembly.....	53
2.3 System Power.....	12	5.26 Meowth Topside Assembly.....	54
2.4 SPIKE Node Addresses.....	12	5.27 Meowth Bushing Cradle.....	54
2.5 SPIKE Node Programming.....	13	5.28 Meowth Balloon Mech.....	54
2.6 SPIKE System Terminology.....	13	5.29 Meowth Pinned Asm.....	55
2.7 Common SPIKE Node Boards.....	13	5.30 Meowth Top Bracket.....	55
<b>3. Light, Switch, and Driver Reference.....</b>	<b>14</b>	5.31 Back Meowth Link Asm.....	55
3.1 SPIKE Node Boards.....	14	5.32 Front Meowth Link Asm.....	55
3.2 Driver Reference.....	15	5.33 Meowth Spring Assembly.....	56
3.3 Switch Reference.....	17	5.34 Meowth Motor Assembly.....	56
3.4 Light Reference.....	21	5.35 Meowth Mech, Motor Asm.....	56
3.5 Motor Reference.....	26	5.36 Crank Arm For Meowth Motor (Has Spring Order).....	57
<b>4. Electronic Pinouts and Schematics.....</b>	<b>27</b>	5.37 Meowth Balloon Assembly (Replacement Version).....	58
4.1 SPIKE-3 CPU Node 0.....	27	5.38 Ball Guide -02 Assembly with Spinner.....	58
4.2 Cabinet Node 1.....	29	5.39 Reflective Opto Spinner, Ball Guide Mount.....	58
4.3 Lower Playfield 48V Driver Pinout Node 8.....	30	5.40 Ball Guide -04 Assembly.....	59
4.4 Mid Upper Playfield 48V Driver Pinout Node 9.....	31	5.41 Ball Guide -06 Assembly.....	59
4.5 12W BC LED Board 8b.....	32	5.42 Ball Guide -12 Assembly.....	59
4.6 4W MC LED Board 8b1.....	33	5.43 Ball Guide -15 Assembly.....	59
4.7 1R 4W ML LED Board 8c1.....	33	5.44 Ball Guide -16 Assembly.....	60
4.8 6R 4W ML LED Board 8c.....	33	5.45 Newton Ball Switch Assembly.....	60
4.9 5R TC LED Board 9a.....	34	5.46 3-Target Stand Up Bank With LED PCB (BATTLE).....	60
4.10 Trough Serial Opto Transmitter.....	34	5.47 R/U Switch Gate Assembly.....	60
4.11 3R TC LED Board 9b1.....	34	5.48 Pikachu Ramp Assembly.....	61
4.12 3R TC LED Board 9b2.....	34	5.49 One Way Gate (Pikachu Ramp).....	62
4.13 Billboard 4-LED Board.....	34	5.50 Opto Receiver Assembly (Pikachu Ramp).....	62
4.14 6R 4W MR LED Board 9b.....	35	5.51 Up Post Assembly, Long (Pikachu Ramp).....	62
4.15 Isolated Smart LED PSU.....	36	5.52 Servo Motor Board Asm.....	62
4.16 SPI Node 10.....	37	5.53 Pikachu Mech Assembly.....	63
4.17 Multi-Servo Interface SPI Board 10A.....	37	5.54 Servo Horn Assembly.....	63
4.18 Trough Serial Opto Receiver 8A.....	37	5.55 Pikachu Body Assembly.....	63
4.19 Power Distribution Board.....	38	5.56 Side Mount Switch Assembly.....	64
4.20 Power Supply 48V/600W.....	39	5.57 Poké Ball Ramp Coil Assembly.....	64
4.21 Power Supply 48V/600W.....	39	5.58 Plastic 01 Assembly.....	65
4.22 Power Plug Wiring.....	39	5.59 Plastic 02 Assembly.....	65
<b>5. Parts Reference.....</b>	<b>40</b>	5.60 Plastic 04 Assembly.....	65
5.1 Playfield Rubber Parts.....	40	5.61 Plastic 09 Assembly.....	65
5.2 Rubber Size Chart.....	40	5.62 Plastic 05 Assembly.....	66
5.3 Playfield Assemblies, Top.....	41	5.63 Plastic 06 Assembly.....	66
5.4 Playfield Assemblies, Bottom.....	42	5.64 Plastic 10 Assembly.....	67
5.5 Backbox Parts.....	43	5.65 Plastic 11 Assembly.....	67
5.6 Lockdown Bar Assembly W/ Center Button.....	43	5.66 Plastic 13 Assembly.....	67
5.7 Speaker Panel Assembly.....	44	5.67 Subway VUK Assembly.....	68
5.8 Speaker Bracket Mount Assembly.....	44	5.68 Poké Ball Ramp Subway Assembly.....	68
5.9 Speaker Panel Assembly [LE].....	45	5.69 Poké Ball Ramp Assembly.....	69
5.10 Speaker Bracket Mount Assembly [LE].....	45	5.70 Poké Ball Mech Assembly.....	69
5.11 Cabinet Parts.....	46	5.71 Electric Control Gate Assembly, Left Mount.....	70
5.12 Ball Shooter Assembly.....	47	5.72 Magnet Assembly (Arena).....	70
5.13 Auto Launch Assembly.....	47	5.73 Backpanel Assembly.....	71
5.14 Ball Trough Assembly.....	48	<b>6. Specifications.....</b>	<b>72</b>
		6.1 Game Dimensions.....	72
		6.2 Warranty.....	73
		6.3 Warnings, Compliance, and Legal Notices.....	73
		6.4 Stern Pinball End User License Agreement.....	74



# 1. SETUP AND MOVING

## 1.1 FIRST-TIME SETUP INSTRUCTIONS

Your brand new Stern Pinball Machine is carefully packed for safety and security. For your safety, exercise caution and use the correct tools and sufficient help when setting up your new game.

### TOOLS REQUIRED

- 5/8" Socket Wrench
- Utility Knife
- Snips
- An Assistant

**CAUTION: AT LEAST TWO (2) PEOPLE ARE REQUIRED TO MOVE AND MANEUVER THE GAME. USE PROPER MOVING EQUIPMENT AND EXTREME CARE WHILE HANDLING. STERN PINBALL MACHINES WEIGH OVER 250LBS BOXED.**

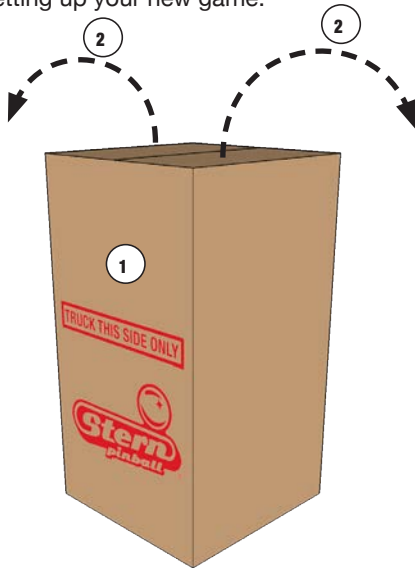

1. Locate the side labeled "TRUCK THIS SIDE ONLY". The bottom of the game faces this side.
2. Open the top box flaps by pulling hard in an upward motion on each flap. If the flaps are taped, cut the tape first, taking care to avoid the box staples.

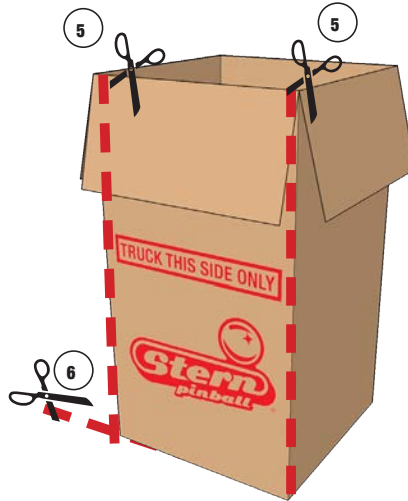

3. Remove the four (4) foam pieces and two (2) narrow box tubes which contain the four (4) identical legs with levelers.
4. DO NOT CUT STRAPPING YET. Keep backbox secured in the down position.
5. With the utility knife, carefully cut down the left and right corners of the box.

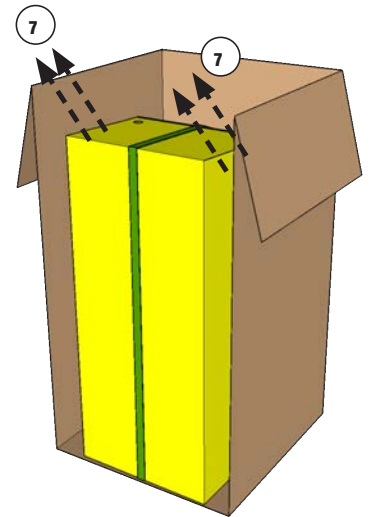

6. Let the face fall forward and remove the entire side by carefully cutting the bottom.
7. With the game still in its folded position, use a 5/8" wrench to loosen and remove the 2 leg bolts on each side of the front cabinet. Ensure the leg levelers are screwed all the way into the legs.

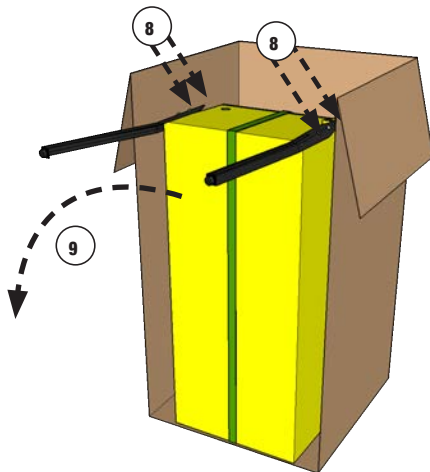

8. Install front legs using the bolts removed from the cabinet. Secure tightly.
9. Have someone help you carefully set the game down on the front legs.

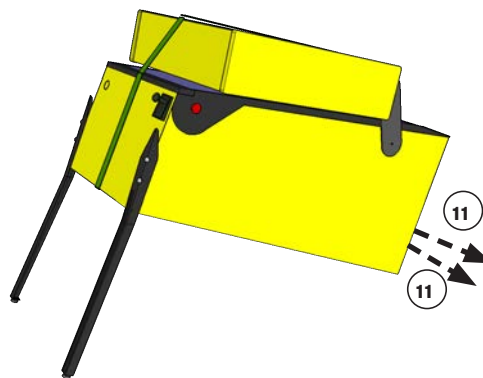

10. Set aside the open box.
11. With a 5/8" socket wrench, loosen and remove the 2 leg bolts on each side of the rear cabinet, 4 total.

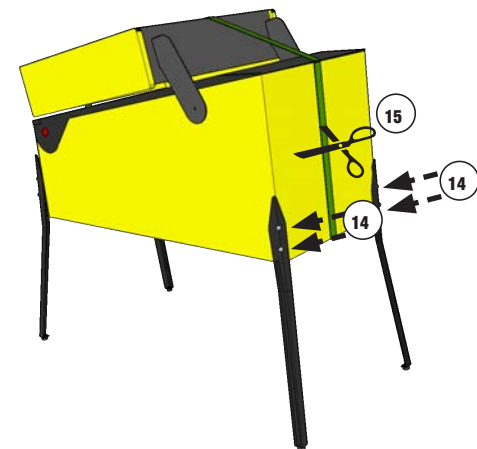

12. Using supports or two people, prop the rear of the cabinet up.
13. Ensure the rear leg levelers are screwed all the way into the legs.
14. Install rear legs using the 4 bolts removed from step 11.

# FIRST-TIME SETUP CONTINUED



- 15. Cut nylon strapping and remove protective strap corner guards.
- 16. Locate the factory keys, either on the shooter rod or taped to the playfield glass.
- 17. Using snips, cut the tie-wrap securing the keys if required. One set of keys is for the front coin door, the other set of keys is for accessing components in the backbox.

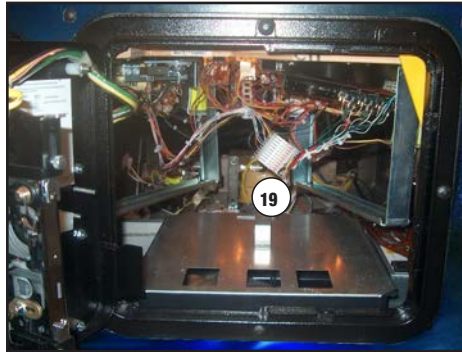

- 18. Open the front coin door.
- 19. Reach into the game and remove the retaining clip at the rear of the cash box.
- 20. Remove the cash box lid by sliding it toward you.

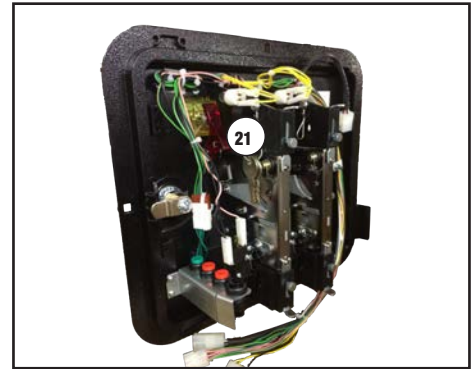

- 21. Store the backbox keys, if desired, on the metal hook located in the coin door.
- 22. Locate and remove the pinballs, plumb bob, and backbox bolts from the cash box.
- 23. Replace the cash box lid and retaining clip for future use.

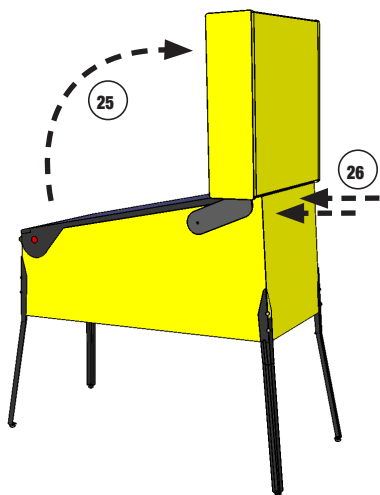

- 24. Locate the two (2) backbox bolts in the cash box.
- 25. Carefully raise backbox to upright position while ensuring that cables are not pinched.
- 26. Use the 5/8" wrench to install the two (2) backbox bolts to secure the backbox as indicated on the back of the cabinet.

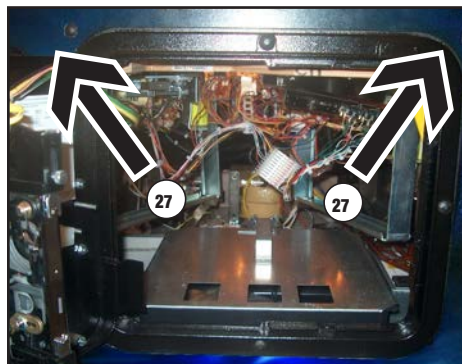

- 27. Reach inside the cabinet and lift the two latches located on either side of the coin door.
- 28. Remove the front top molding.



- 29. Remove the playfield glass by sliding it toward you and carefully place it in a safe location. Remove all playfield shipping tie downs, shipping blocks, and packing foam, and follow any game-specific unpacking instructions included in the playfield, if present.

**CAUTION: PLAYFIELD GLASS IS MADE FROM HIGH-STRENGTH TEMPERED GLASS. TEMPERED GLASS IS SENSITIVE TO EXTREME TEMPERATURE SHIFTS AND CORNER NICKS, WHICH CAN CAUSE THE GLASS TO FAIL CATASTROPHICALLY. TAKE CARE TO STORE THE GLASS ON A SOFT, ROOM-TEMPERATURE SURFACE AND PREVENT THE CORNERS FROM BEING DAMAGED.**

## FIRST-TIME SETUP CONTINUED

30. If pinballs were already installed into the lower ball trough, remove them before lifting the playfield.
31. Grasp the lower arch between the flippers, and firmly but gently pull directly up to raise the playfield 8 to 12 inches.
32. While holding the playfield up, pull the playfield toward you until the two playfield supports are over the front edge of the cabinet.
33. Rest the playfield on the front edge of the cabinet.
34. Raise the playfield and rest it against the backbox.
35. Visually inspect all cabinet cables and connector terminations; ensure no wires or cables are pinched and that cable harnesses are not pulled tight.
36. Locate the plumb bob in the parts bag in the cash box.
37. Slide plumb bob onto the hanger wire. Note: the vertical position of the plumb bob affects tilt sensitivity - higher makes the game more sensitive to tilting.
38. Tighten the thumb screw finger-tight.
39. Install the correct number of pinballs. Refer to the decal on the lock down assembly for the correct number of pinballs.

## LOCATING, LEVELING, AND FINAL SETUP

1. Select a location that is indoors, out of direct sunlight, and climate controlled. Excessive moisture/humidity can cause long-term damage to your game.
2. Adjust the front or rear levelers as necessary to position the playfield level bubble, located on the front right of the playfield next to the shooter lane, to float between the two (2) black lines. This will place the playfield at the recommended 6.5° pitch. Playfield angles greater than 6.5° can be achieved by turning out the rear leg leveler(s) for increased difficulty and faster gameplay.
3. Use a pinball to roll down the center of the playfield for side-to-side leveling, or use an external bubble level, digital level, or smartphone level app.
4. Plug into a grounded outlet and check for proper operation through DIAGNOSTICS.
5. Check the coin door: With the door closed, insert coins to verify proper operation.
6. Play game: Check for satisfactory operation and adjust game volume (push the Red Buttons inside the Coin Door).
7. If desired, perform any game diagnostics, game adjustments, and pricing settings at this time.

## SPIKE PINBALL SOFTWARE UPDATE INSTRUCTIONS



1. Obtain game software update file (filename ends in “.spk”) from [www.sternpinball.com](http://www.sternpinball.com) or from authorized Stern distributor.
2. Place game software update file ( “.spk”) in root directory of a blank FAT32-formatted USB flash drive (NTFS Format will also work).
3. Use backbox power switch to turn off game.
4. Plug in USB flash drive to CPU board USB connector (CN9).
5. Turn on game.
6. The game will automatically begin software update.
7. Select the correct .spk update file from list.
8. Press Enter on the service switches to start update.
9. When the display indicates “Update Complete”, turn off game.
10. Remove USB flash drive from CPU board.
11. Turn game on to complete the update and play pinball!
12. Detailed instructions and troubleshooting tips are available in the game manual, [www.sternpinball.com](http://www.sternpinball.com) and authorized Stern distributors.
13. If the game is connected to the internet, and registered to an Insider Connected account, the software can be automatically downloaded and installed.

### POWER SWITCH

The game’s power switch is located on the right-hand side underneath the backbox.

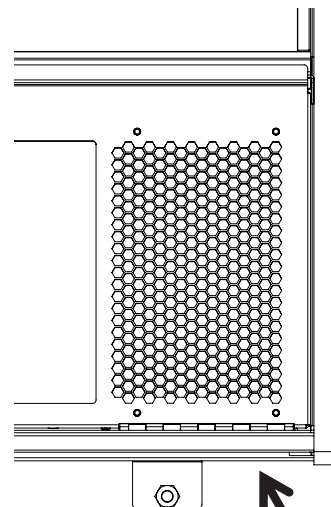

ON/OFF Switch











## 1.2 SERVICE MENU NAVIGATION

The four service buttons (inside Coin Door) have multiple functions. The buttons react differently depending on what state the game is currently in.









### FUNCTIONS DURING GAME OR ATTRACT MODE

PRESS  SELECT for SERVICE MENU

 <b>BACK</b>	  / 	  / 	 <b>SELECT</b>
<b>Green</b> Press to add service credit(s).	<b>Left Red</b> Press to decrease the volume (quieter).	<b>Right Red</b> Press to increase the volume (louder).	<b>Black</b> Press to enter the Service Menu.









### FUNCTIONS DURING SERVICE MENU

PRESS  SELECT for SERVICE MENU

 <b>BACK</b>	  / 	  / 	 <b>SELECT</b>
<b>Green</b> Press to go back to the last menu or exit.	<b>Left Red</b> Press to move highlighted option up.	<b>Right Red</b> Press to move highlighted option down.	<b>Black</b> Press to Select the current highlighted option.

### FUNCTIONS WHEN MAKING ADJUSTMENTS

PRESS  SELECT for SERVICE MENU

 <b>BACK</b>	  / 	  / 	 <b>SELECT</b>
<b>Green</b> Press to cancel change.	<b>Left Red</b> Press to decrease the current adjustment.	<b>Right Red</b> Press to increase the current adjustment.	<b>Black</b> Press to confirm / save the change.

## SERVICE MENU



The first screen when entering the Service Menu contains information about your game.

- A. IP Address** - Shows the current IP Address the game is receiving from the network.
- B. Config ID** - Your game's unique identifier to the servers. This comes from the CPU and game version.
- C. Firmware Versions** - This will have two versions shown, they are for the overall software running the game.
- D. Network Status** - Shows the current Wi-Fi signal and network name, or Wired Connection.
- E. Game Title** - Shows the game title and version. This comes from the software installed.
- F. Game Code** - Shows the current software version installed.
- G. QR Code** - Scanning this QR Code will bring you directly to Insider Connected.
- H. Status Symbol** - This is a quick glance to see if the game is registered.



SERVICE MENU CONTINUED



Pressing the Select button will continue to the Main Menu. While in the Main Menu, pressing the Back/Escape button will exit back to the game.

Use the volume buttons to change the option highlighted. In the image above, Quick Adjustments is highlighted, and pressing the Select button will enter that menu.



Quick Adjustments has the more common settings that help for a quick setup of the game.

Pressing the volume buttons will move through the options here. Pressing Select on an option allows the volume buttons to change current value/setting. Save the change with the Select button, or cancel the change with the Back/Escape button.

To go back to the previous menu, press the Back/Escape button.

Service Menu Table Of Contents

Quick Adjustments

Diagnostics

- Switch Test
- Coil Test
- LED Test
- Node Board Test
- Technician Alerts

Device Tests

- Ball Trough Test
- Sound/Speaker Test
- Game Specific Device Tests

Audits

- Play Counts
- Awards
- Scores
- Time
- Earnings Audits
- Diagnostic Audits
- Game Play Audits
- Dump Audits to USB
- Dump Audits to USB (Comp)

Adjustments

- Pricing
- Game Play Settings
- Machine Settings

Stern Insider Connected™

- About
- Setup Connection
- Test Connection
- Game Registration
- Software Update
- Setup Home Team™
- Change Settings

Utilities

- Presets
- Start Guided Setup
- Enter Custom Message
- Save Settings
- Restore Settings
- Resets

Tournament Menu

Redemption Menu



## SERVICE MENU DEFINITIONS

### Quick Adjustments

- » The most commonly changed adjustments are located here.

### Diagnostics

- **Switch Test**
- **Coil Test**
- **LED Test**
- **Node Board Test**
- **Technician Alerts** (located here in addition to the main page)

### Device Tests

- **Ball Trough Test**
- **Sound/Speaker Test**
- **Game Specific Device Tests**

### Audits

- **Play Counts**
  - » Counts of games and balls played, plus any play count specific audits unique to the game.
- **Awards**
  - » Counts of replays, extra balls, specials, and matches awarded, plus any award specific audits unique to the game.
- **Scores**
  - » Counts of game scores, split into divisions of score ranges.
- **Time**
  - » Average ball and game time, plus counts of total game time, .... split into divisions of time ranges.
- **Earnings Audits**
  - » Counts of coins deposited, credits paid, service credits and .... other counts related to money and earnings.
- **Diagnostic Audits**
  - » Counts of ball searches, lost balls, power on time, and other .... counts related to machine operation.
- **Game Play Audits**
  - » Game audits unique to the game.
- **Dump Audits to USB**
  - » Save the audits to a text file on a USB storage device. Includes Game and Location IDs set via the machine adjustments. Audit text will ..... include mixed upper/lower case letters.
- **Dump Audits to USB (Comp)**
  - » Save the audits to a text file on a USB storage device, in a format . similar to previous software release. Game and Location IDs will not be present in this file, and all audit text will be upper case only.

### Adjustments

- **Pricing**
  - » Game pricing and coin door settings, and on-screen credit ..... formatting options.
- **Game Play Settings**
  - **Player and Ball Settings**
    - » Ball and players per game, tilt adjustments, ball save timer and plunger settings.
  - **Game Settings**
    - » Game play adjustments unique to the game.
  - **Game Types**
    - » For games with multiple types of play modes, the enabling and disabling of these play types.
  - **Standard High Scores**
    - » High score default scores and award settings. High score initial entry settings and how often they will be reset.
  - **Game High Scores**
    - » Game specific high scores defaults.

### Machine Settings

- **Machine Operation**
  - » Controls how the start and action buttons behave, the ticket dispenser settings and the Game and Location IDs (used for audit dumps).
- **Devices**
  - » Allows you to disable certain game devices, so the game will ... continue to function while repairs are being made.
- **Coil Settings**
  - » Adjust the power settings of flippers and coils, and any settings relevant to any game specific devices.
- **LCD/Lamp**
  - » Brightness settings for lamps and the LCD screen.
- **Audio Settings**
  - » Main volume settings, plus any individual volume settings ..... specific to this game.
- **Audio Configuration**
  - » Speaker, Volume, and sound setup settings.
- **Attract Mode**
  - » Control of some attract mode displays.

### Stern Insider Connected™

- **About**
  - » Network connection details
- **Setup Connection**
  - » Connect this game to the internet.
- **Test Connection**
  - » Test the machine's internet connection.
- **Game Registration**
  - » Register this game with Stern Insider Connected. Display the .. registration details, and unregister games.
- **Software Update**
  - » Check for, download, and install any software updates. Enable/ Disable updates and change the download scheduling.
- **Setup Home Team™**
  - » For non-commercial settings, scan players to the Stern Insider . Connected™ account, so connected games can be played ..... without having to scan in each time.
- **Change Settings**
  - » Stern Insider Connected™ related adjustments, including start . button behavior, play again times, and home team settings.

### Utilities

- **Presets**
  - » Change the game settings en-mass from a selection of grouped adjustment settings.
- **Start Guided Setup**
  - » Enter the guided setup menu, setting up the machine for the .... first time.
- **Enter Custom Message**
  - » Enter a message unique to this specific game that will **display in the attract mode.**
- **Save Settings**
  - » Save the settings to a USB storage device.
- **Restore Settings**
  - » Restore the settings from a USB storage device.
- **Resets**
  - » Allows resetting coin, game, and high score audits, credits, audio and other settings back to default values.

### Tournament Menu

- » Allows the configuration of a built-in tournament on this game.

### Redemption Menu

- » Allows the configuration of a game that dispenses tickets during game play.

# 1.3 GAME PRICING REFERENCE TABLE

Country	ID	Pricing (Credits / Cost)						Unit per Pulse	Coin Door Pulse Settings					
									Left	Center	Right	4th	5th	6th
Australia	1	1/\$1.00 AU	3/\$2.00 AU					\$0.10 AU	2	10	20	50	5	0
	2	1/\$1.00 AU												
	3	1/\$2.00 AU												
	4	1/\$2.00 AU	2/\$4.00 AU	3/\$5.00 AU										
	5	1/\$2.00 AU	2/\$3.00 AU											
Canada	1	1/\$0.50 CN	2/\$0.75 CN	3/\$1.00 CN			\$0.25 CN	1	1	4	8	0	0	
	2	1/\$1.00 CN	3/\$2.00 CN				\$1.00 CN	1	1	2	2	0	0	
China	1	1/5 Yuan	3/10 Yuan				1 Yuan	1	1	1	0	0	0	
	2	1/10 Yuan	2/15 Yuan											
Croatia		1/3 kuna	2/5 kuna				1 kuna	1	2	5	1	0	0	
Denmark	1	1/3 DKr	2/5 DKr				1 DKr	1	5	10	20	0	0	
	2	1/2 DKr	2/4 DKr	3/5 DKr	4/7 DKr	5/9 DKr								7/10 DKr
	3	1/5 DKr												
	4	1/10 DKr												
	5	1/20 DKr												
	6	1/10 DKr	3/20 DKr											
Euro	1	1/EUR 0.50					Electronic EUR 0.10	5	10	20	2	0	0	
	2	1/EUR 0.50	2/EUR 1.00	3/EUR 1.50	5/EUR 2.00									
	3	1/EUR 0.50	3/EUR 1.00											
	4	1/EUR 1.00	2/EUR 2.00	3/EUR 3.00	5/EUR 4.00									
	5	1/EUR 1.00	3/EUR 2.00											
	6	1/EUR 1.00	2/EUR 1.50	3/EUR 2.00										
	7	1/EUR 1.00	3/EUR 2.00	7/EUR 3.00			Mechanical EUR 0.10	5	1	5	1	0	0	
	8	1/EUR 1.00	4/EUR 2.00											
	9	2/EUR 1.00	4/EUR 2.00	6/EUR 3.00	9/EUR 4.00									
	10	1/EUR 2.00	2/EUR 3.00	3/EUR 4.00										
	11	1/EUR 2.00	2/EUR 4.00	3/EUR 5.00										
	12	1/EUR 2.00	3/EUR 4.00	7/EUR 6.00										
Indonesia	1	1/20000 Rp	2/40000 Rp	3/50000 Rp	4/60000 Rp	5/80000 Rp	8/100000 Rp	10,000 Rp	0	0	0	0	0	1
	2	1/20000 Rp	2/40000 Rp	4/50000 Rp	5/60000 Rp	6/80000 Rp	10/100000 Rp							
	3	2/20000 Rp	4/40000 Rp	6/50000 Rp	8/60000 Rp	10/80000 Rp	13/100000 Rp							
Japan	1	1/YEN 100						Yen 100	1	1	1	1	0	0
	2	1/YEN 100	3/YEN 200											
	2	1/YEN 200												
Lithuania		1/2 LTL					1 LTL	1	2	5	0	0	0	
Middle East		1/1 token					1 token	1	1	1	1	0	0	
New Zealand	1	1/\$1 NZ					\$1 NZ	1	1	2	1	0	0	
	2	1/\$1 NZ	3/\$2 NZ											
	3	1/\$2 NZ	2/\$3 NZ											
Norway	1	1/10 Nkr					1 Nkr	1	5	10	20	0	0	
	2	1/10 Nkr	3/20Nkr											
	3	1/20 Nkr												
	4	1/20 Nkr	3/40 Nkr											
	5	1/5 Nkr												
Russia		1/5 RUB					1 RUB	10	5	1	1	0	0	
South Africa	1	1/R2					R 0.50	1	2	4	10	0	0	
	2	1/R3	2/R5											
Sweden	1	1/10 SKr	2/15 SKr	3/20 SKr			1 SKr	1	5	10	2	0	0	
	2	1/5 SKr												
	3	1/10 SKr												
	4	1/20 SKr												
	5	1/10 SKr	3/20 SKr											
Switzerland	1	1/1 SwF	2/2 SwF	3/3 SwF	4/4 SwF	6/5 SwF	1 SwF	1	2	5	1	0	0	
	2	1/2 SwF	2/4 SwF	3/5 SwF										
Taiwan		1/10 TWD					10 TWD	1	1	1	1	0	0	
UK	1	1/2.00					10p	1	5	10	2	20	0	
	2	1/1.00												
	3	1/50p	2/1.00	3/1.50	5/2.00									
	4	1/2.00	2/3.00	4/5.00										
	5	1/1.00	3/2.00											
USA	1	1/\$0.25					\$0.25	1	4	1	1	0	0	
	2	1/\$0.50	2/\$0.75	3/\$1.00										
	3	1/\$0.50												
	5	1/\$0.50	2/\$1.00	3/\$1.50	5/\$2.00									
	7	1/\$0.50	2/\$1.00	4/\$1.50	6/\$2.00									
	8	1/\$0.50	3/\$1.00											
	9	1/\$1.00												
	10	1/\$0.75	2/\$1.50	3/\$2.00										
	11	1/\$1.00	3/\$2.00											
	12	1/\$0.25	2/\$0.50	3/\$0.75	5/\$1.00									
	13	1/\$1.00	2/\$2.00	3/\$3.00	4/\$4.00	7/\$5.00								

## 1.4 TRANSPORTING THE GAME

When transporting the game, such as in the back of a truck or with a hand truck, the game's backbox must be secured to prevent damage to the side rails.

### 1. SECURE THE BACKBOX

1. Ensure that the pinballs are removed from the playfield, and secure any free-moving mechanisms that may get damaged in transport

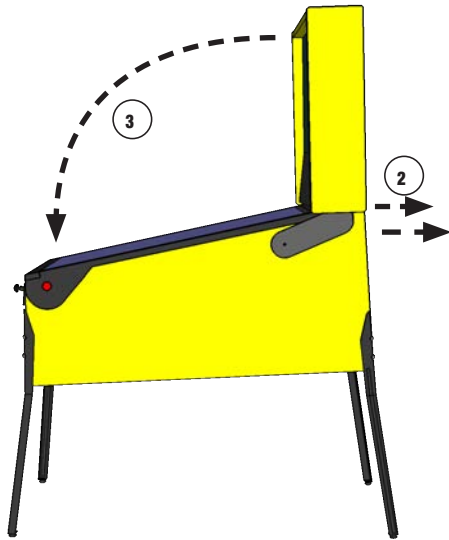

2. Remove the backbox securing bolts
3. Carefully lower the backbox onto the side rails. Use a piece of cardboard or suitable padding between the backbox and the game.

**TOOLS REQUIRED** ⓘ

- STRAP (500LB OR GREATER)
- AN ASSISTANT
- HAND TRUCK

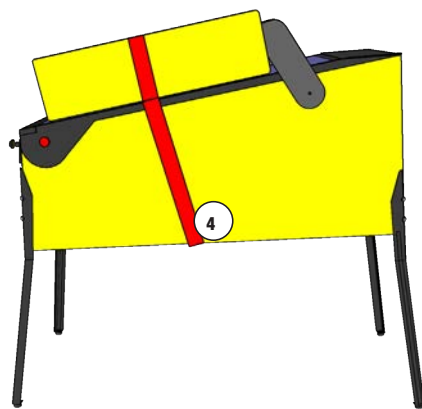

4. Securely strap the back box to the game
5. The game may be transported with the legs on. If the legs must be removed, follow the remaining steps.

### CAUTION

**NEVER TRANSPORT THE GAME IN A MOVING VEHICLE WITH THE BACKBOX RAISED! TWO PEOPLE ARE REQUIRED TO REMOVE THE LEGS!**

### 2. REMOVE THE LEGS AND STAND UP

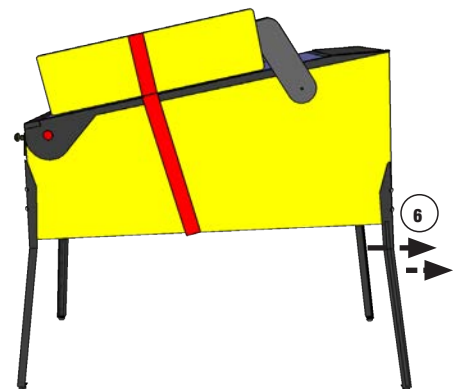

6. Remove the legs, rear legs first. Use a stool or a friend to support the rear of the game.
7. Rest the rear of the game on the ground.

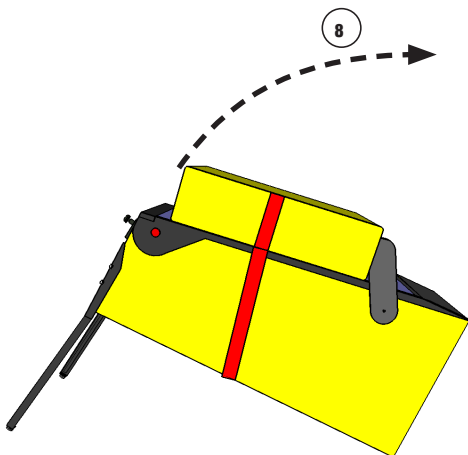

8. Stand the game up on its back.

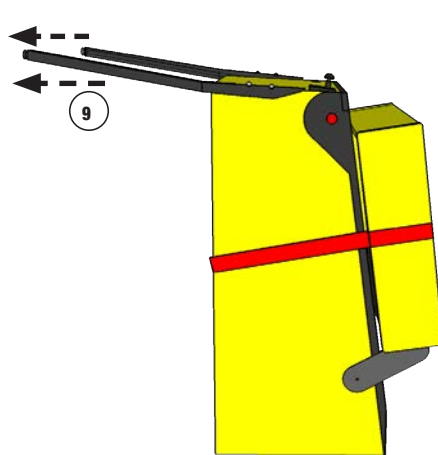

9. Remove the front two legs.

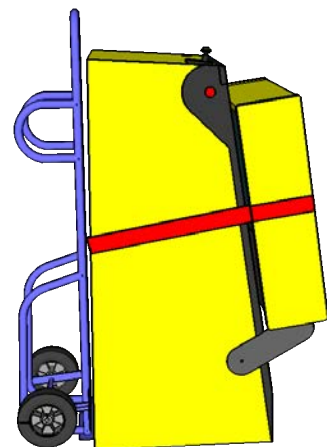

10. Secure all loose parts and transport with a hand truck in the upright position.

## 1.5 MAINTENANCE

### REGULAR MAINTENANCE - (MONTHLY/500 GAMES)

- Remove the playfield glass
- Enter the software diagnostics menu, start lamp test, then clean and wax the playfield.
  - While cleaning the playfield, identify and repair malfunctioning lights, loose parts, cracked plastics and worn rubber parts.
- While in diagnostics, enter the switch test (Select the "SW" Icon, then "TEST" Icon).
  - Use a pinball to actuate all switches and verify the correct switch registers with the switch test.
  - The game will play a sound to confirm the switch.
- Lift the playfield and inspect all assemblies for loose parts, broken wires or excessive wear. Look at the bottom of the cabinet for any parts that may have worked loose, then find the source.
- Check all coin door mechanisms and bill acceptor (if installed) for proper operation
- Play the game to ensure all coils and features are working
- Check the playfield to ensure it is level and set to the proper pitch using the bubble level on the right side wood rail.
- Check game audits: Replay % and Ball Time and note abnormal values which can indicate problems.
- Ensure game volume is set appropriately for the location.
- Clean both sides of the playfield glass and reinstall.
- Check and clean pinballs and replace if excessively worn or scuffed. Dirty pinballs accelerate game wear.

### OVERHAUL MAINTENANCE - (5000 GAMES)

- Verify latest game software is installed
- Check flippers for excessive wear. Excessive flipper sloppiness (vertical or horizontal) or weakness indicates a flipper rebuild is required.
- Clean machine inside and out and check leg levelers for free operation.
- Visual check for loose or broken playfield and cabinet parts and repair as necessary.
- Electrical check: Plug into grounded outlet and check for proper operation through DIAGNOSTICS.
- Replace worn or dirty rubbers.
- Replace pinballs.
- Check all playfield switches with a pinball.
- Check all settings (refer to manual for factory settings).
- Check coin door: With door closed, insert coins to verify proper operation.
- Check for proper adjustment of the plumb bob tilt.
- Play game: Check for satisfactory operation.

### COMMON PINBALL TOOLS

- Common nut drivers (1/4", 5/16", 11/32", 3/8")
- Phillips screwdriver
- Standard Allen wrench/Hex key set
- 5/8" Socket with ratchet
- Adjustable wrench (5/8" & 9/16")
- 6" Torpedo Level (or use a pinball)
- Flashlight or headlamp
- Soldering Iron (60w with flat tip), lead-free solder
- Wire cutter
- Wire stripper
- Long nose ("needle nose") pliers

## 1.6 MAINTENANCE KITS

Description	Part Number
POKÉMON LE / Premium Playfield Plastics Kit	803-5000-AJ
POKÉMON LE / Premium Playfield Decals Kit	802-5000-AJ
POKÉMON LE Backbox Decal Left	820-90AJ-01
POKÉMON Premium Backbox Decal Left	820-81AH-01
POKÉMON LE Backbox Decal Right	820-90AJ-02
POKÉMON Premium Backbox Decal Right	820-81AH-02
POKÉMON LE Cabinet Decal Left	820-90AJ-03
POKÉMON Premium Cabinet Decal Left	820-81AH-03
POKÉMON LE Cabinet Decal Right	820-90AJ-04
POKÉMON Premium Cabinet Decal Right	820-81AH-04
POKÉMON LE Cabinet Decal Front	820-90AJ-05
POKÉMON Premium Cabinet Decal Front	820-81AH-05
POKÉMON LE / Premium Playfield, Bare	830-5100-AJ
POKÉMON LE Mirror Backglass	830-8426-AJ
POKÉMON Premium Translite	830-8427-AH

## 1.7 COMMON PARTS

Description	Part Number
8 oz Pinball Playfield wax (Novus # 2)	675-0003-01
Standard Pinball, 1-1/16 in	260-5000-00
Flipper Rebuild Kit Left (Standard)	500-6307-10
Flipper Base Plate Kit Left	515-6617-01
Flipper Rebuild Kit Right	500-6307-00
Flipper Base Plate Kit Right	515-6617-00
Memory Card - MicroSD	970-0142-64
Wi-Fi Adapter	509-2013-00



## 2. SPIKE SYSTEM AND NODE GUIDE

### 2.1 SPIKE SYSTEM OVERVIEW

The SPIKE Pinball system is a rugged, distributed, and embedded platform custom-designed for the rigors of the pinball machine environment. SPIKE takes advantage of modern technologies to deliver an immersive pinball experience that supports modern features, reduces cabling, and increases serviceability and reliability.

A Stern Pinball machine based on the SPIKE system will have at least two nodes networked together with the SPIKE node bus, a custom industrial pinball control bus that is designed around industry standards and optimized for the pinball environment. The primary CPU node is networked to one or more input/output nodes over standard Category 5 UTP (unshielded twisted pair) ethernet cabling.

There are five primary types of nodes that are found in the game.

- CPU node (Node 0) - The primary node that controls other nodes in the system. Contains the primary game software for the system and provides SPIKE node bus power for other nodes.
- Cabinet 48V node (Node 1) - Specialized node with specific inputs and outputs for coin doors, tilt mechanisms, and other bottom-cabinet devices.
- 48V playfield node - Controls high power devices such as coils and flashers, and also supports a few switch and low-power outputs. Powered by the system 48V power supply.
- Light and switch node - High-density switch and low-power LED outputs, bus-powered from the node bus. These boards contain as many 32 switch inputs and light outputs.
- Node extensions - These sub-nodes add additional low-power input and outputs to a specific Power or I/O node and are connected with simple serial bus.

### 2.2 NODE BUS CABLING

The SPIKE node bus utilizes standard Ethernet-style RJ45 8-pin modular jacks, and off-the-shelf Category 5e or better ethernet cabling. The node bus is electrically different from Ethernet and does not utilize Ethernet or TCP/IP protocols or signaling standards. SPIKE nodes are not compatible with standard computer networking equipment.

*CAUTION: Plugging a SPIKE Node or CPU board into a standard Ethernet port may damage one or both devices and may void your warranty.*

### 2.3 SYSTEM POWER

The SPIKE System is powered from an 48V DC power supply bus. Each SPIKE node converts this voltage to lower voltages required by the node and its specific components. A SPIKE 48V node typically controls high-power outputs such as game coil mechanisms and high-brightness LEDs. These powered nodes are supplied directly with 48V system power. SPIKE standard I/O nodes are low-power nodes that read switch inputs and output to standard-brightness LEDs. Standard I/O nodes use the node bus power, which is supplied by the main CPU node over the node bus modular jack connectors.

### 2.4 SPIKE NODE ADDRESSES

Each SPIKE node has a unique address ranging from 0 to 15. Not all addresses are used in all games. Nodes can be of the same part number, so the address is specified on the DIP switches on each node. When replacing a node, be certain that the correct address is set. Nodes can have 3-position and 4-position DIP switches. Refer to the appropriate table to set the address for each type of Node. The correct address for a node can be found in the SPIKE node reference section of the manual or in the game diagnostic software. Address 0 is reserved for the backbox CPU node, where the game software resides. Address 1 is reserved for the cabinet node, located inside the coin door. These two nodes do not have DIP switches as their address is not configurable.

Address	1	2	3	4
8	OFF	OFF	OFF	OFF
9	OFF	OFF	ON	OFF
10	OFF	ON	OFF	OFF
11	OFF	ON	ON	OFF
12	ON	OFF	OFF	OFF
13	ON	OFF	ON	OFF
14	ON	ON	OFF	OFF
15	ON	ON	ON	OFF

SPIKE node addresses for nodes with 4-position DIP switches. Addresses 0-7 are reserved for fixed-function nodes and do not require configuration.

## SPIKE SYSTEM AND NODE GUIDE CONTINUED

### 2.5 SPIKE NODE PROGRAMMING

The SPIKE nodes are smart nodes that have on-board processors and run embedded code. The nodes are programmed automatically by the CPU node whenever software updates are installed to the CPU. When replacing a node, the CPU node will detect and update the node to the latest software with no user intervention. Always replace nodes with the power to the game turned OFF.

### 2.6 SPIKE SYSTEM TERMINOLOGY

#### MULTI GENERAL ILLUMINATION LIGHTING

General Illumination Lighting is two or more lights powered by one control source. These are often a number of LEDs connected in parallel and the system controls these as one large LED. A missing LED will not affect these circuits, however a shorted LED can cause the entire string of LEDs to turn off.

#### SINGLE LIGHTS

Single lights and LEDs are direct-controlled from SPIKE node boards. A common power source is grounded by individual transistors to turn individual LEDs on and off. Groups of LEDs, usually by node connector, share a common power source, so if a group of LEDs is out, check the wiring for the power source.

#### FLASHERS

SPIKE games treat flashers the same as single LEDs that draw more power. Flashers are controlled from the same circuits that power regular lights.

#### DRIVERS

A driver is a circuit that controls a high power-device such as a coil, magnet, or motor. Each device has a common 48V power source that is then connected to ground by a dedicated control transistor. Each driver is protected against shorting, static electricity, and over-current conditions. Take caution as 48V is always present on a device even when it is not energized.

#### OPTOS

Certain types of optical switches (“optos”) require external signal conditioning. For these optos, they will interface to a SPIKE node via an opto signal conditioning board. Other optical switches connect directly to the Spike node board.

**CAUTION:** *Unless explicitly directed by an Authorized Stern Repair technician, perform ALL work on your pinball machine with the power disabled!*

### INPUT/OUTPUT PROTECTIONS (OVERCURRENT)

SPIKE features built-in short-circuit, static electricity, and other protections to maximize reliability. If an LED, coil or other device shorts, it will be disabled but will not shut down the entire system in most circumstances. Groups of LEDs, coils, and switches often share common power supplies or other circuits, so it is possible that a bad device will affect the group of related devices and require removal or repair to fix the group. The system diagnostics will inform the technician of shorted or otherwise malfunctioning devices whenever possible. While the system is protected against permanent damage, it is strongly recommended to repair or replace these bad components as soon as possible to minimize downtime and maximize game earnings.

### 2.7 COMMON SPIKE NODE BOARDS

Description	Type	Part Number
SPIKE CPU Node	Node	524-1002-00
Cabinet Node	Node	520-6967-72
Playfield 48V Core-Driver Node	Node	520-1057-00 520-1070-00
Trough Serial Opto Receiver Extension	Extension	520-8516-00
QR Scanner Assembly	Node	524-1001-00

# 3. LIGHT, SWITCH, AND DRIVER REFERENCE

# POKÉMON

PREMIUM & LE MODEL

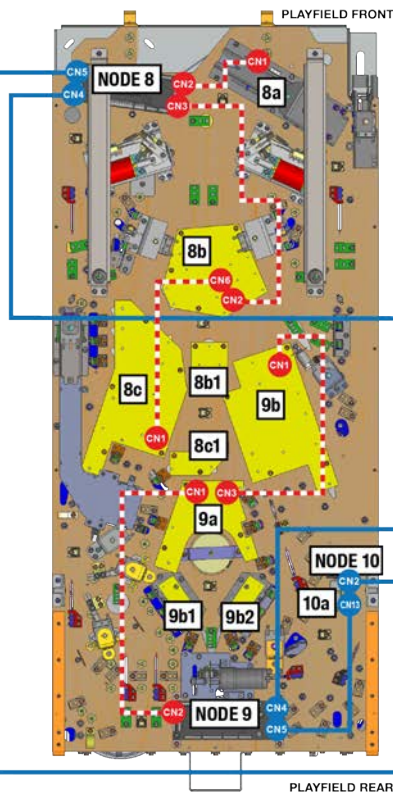
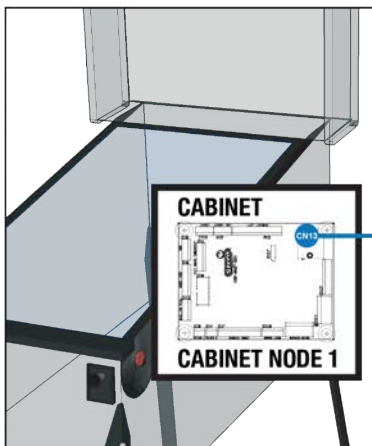
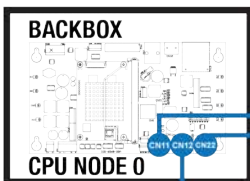
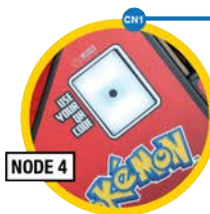

Node Bus Cable (RJ45)  
604-5004-08-XX

Serial Data Cable  
036-8054-XX

When replacing node boards, ensure DIP address switches are set correctly!

OPTIONAL TOPPER

## 3.1 SPIKE NODE BOARDS

ID	DIP Address	Description	Location	Part Number
Node 0	n/a	SPIKE 3 CPU Node	Backbox	524-1002-00
Node 1	n/a	Cabinet Node	Cabinet	520-6967-72
Node 4	n/a	QR Reader Node	Bottom Arch	524-1001-00
Node 8	OFF-OFF-OFF-OFF	Core - Driver Node	Lower Playfield	520-1070-00 520-1057-00
8a	n/a	Trough Serial Opto Receiver Extension	Playfield	520-8516-00
8b	n/a	LED Board -12W BC	Playfield	520-7474-00
8b1	n/a	LED Board -4W MC	Playfield	520-5801-00
8c	n/a	LED Board -6R 4W ML	Playfield	520-9875-00
8c1	n/a	LED Board -1R 4W ML	Playfield	520-9886-00
Node 9	OFF-OFF-ON-OFF	Core - Driver Node	Playfield	520-1070-00 520-1057-00
9a	n/a	LED Board -5R TC-S3	Playfield	520-9880-00
9b	n/a	LED Board -6R 4W MR	Playfield	520-9874-00
9b1	n/a	LED Board -3R TC	Playfield	520-9885-00
9b2	n/a	LED Board -3R TC	Playfield	520-9885-00
Node 10	OFF-ON-OFF-OFF	SPI Node Board	Playfield	520-5370-72
10a	n/a	Multi-Servo Interface SPI Board	Playfield	520-8685-00
Node 0(2)	n/a	(LE Option)	Cabinet-Expression	
Node 0(7)	n/a	(LE Option)	Speaker-Expression	
Node 12	ON-OFF-OFF-OFF	Topper-Lamps(Optional)	Topper	
Node 13	ON-OFF-ON-OFF	Topper-Servo(Optional)		
Node 14	ON-ON-OFF-OFF	Universal Topper (Optional)		



### 3.2 DRIVER REFERENCE

ID	Name	Node	Connector	Ret. Pin	Ret. Wire	Voltage	V+ Pin	V+ Color	Location	Type	Address	Part Number
1	Trough	8	CN8	7	ORG GRY	48V	1-4	GRY ORG	Playfield	Coil - 27-1500	8-DR-1	090-5004-ND
2	Auto Plunger	8	CN8	9	ORG WHT	48V	1-4	GRY ORG	Playfield	Coil - 23-800	8-DR-4	090-5001-ND
3	Left Flipper	8	CN8	6	ORG YEL	48V	1-4	GRY ORG	Playfield	Coil - 23-900	8-DR-5	090-5020-30-ND
4	Right Flipper	8	CN8	5	ORG GRN	48V	1-4	GRY ORG	Playfield	Coil - 23-900	8-DR-0	090-5020-30-ND
5	Left Slingshot	8	CN8	11	ORG BLU	48V	1-4	GRY ORG	Playfield	Coil - 26-1200	8-DR-3	090-5044-ND
6	Right Slingshot	8	CN8	10	ORG VIO	48V	1-4	GRY ORG	Playfield	Coil - 26-1200	8-DR-2	090-5044-ND
7	Shaker Motor	1	CN16	1	BLU	48V	5	RED	Cabinet	Motor	1-DR-0	041-5029-04
8	Trap Door	8	CN7	3	YEL BLK	48V	1	GRY ORG	Playfield	Coil - 26-1200	8-DR-6	090-5044-ND
9	Bowl Diverter	8	CN7	4	YEL BRN	48V	1	GRY ORG	Playfield	Coil - 29-1400	8-DR-7	500-6818-02-ND
10	Left Eject	8	CN7	2	YEL RED	48V	1	GRY ORG	Playfield	Coil - 23-800	8-DR-8	090-5001-ND
11	Top Pop Bumper	9	CN8	10	ORG BLK	48V	1-4	GRY BRN	Playfield	Coil - 26-1200	9-DR-2	090-5044-ND
12	Bottom Pop Bumper	9	CN8	9	ORG RED	48V	1-4	GRY BRN	Playfield	Coil - 26-1200	9-DR-4	090-5044-ND
13	Top Gate	9	CN8	5	YEL VIO	48V	1-4	GRY BRN	Playfield	Coil - 32-1250	9-DR-0	090-5060-01-ND
14	Arena Magnet	9	CN8	6	BRN RED	48V	1-4	GRY BRN	Playfield	Coil - 22-650	9-DR-5	511-5065-ND
15	Pikachu Up Post	9	CN7	3	YEL GRN	48V	1	GRY BRN	Playfield	Coil - 26-1200	9-DR-6	090-5044-ND
16	Meowth Balloon Motor	9	CN7	4	BRN BLK	48V	1	GRY BRN	Playfield	Motor - 041-5132-00	9-DR-7	511-1081-00 (WithCaps&Motor)
17												
18	Right Eject	9	CN7	2	YEL ORG	48V	1	GRY BRN	Playfield	Coil - 23-800	9-DR-8	090-5001-ND
19												
20												
21												
22												
23												
24												
25												
26												
27												
28												
29												
30												
31												
32												
33	Coin Meter	1	CN3	2	BLK	12V	1	RED	Cabinet	Digital Out	1-DR-2	500-9946-00
34	Ticket Meter	1	CN4	2	BLK	12V	1	RED	Cabinet	Digital Out	1-DR-3	500-9946-00
35	Ticket Dispenser	1	CN11	3		12V	1		Cabinet	Digital Out	1-DR-4	

Continued on next page...



DRIVER REFERENCE CONTINUED

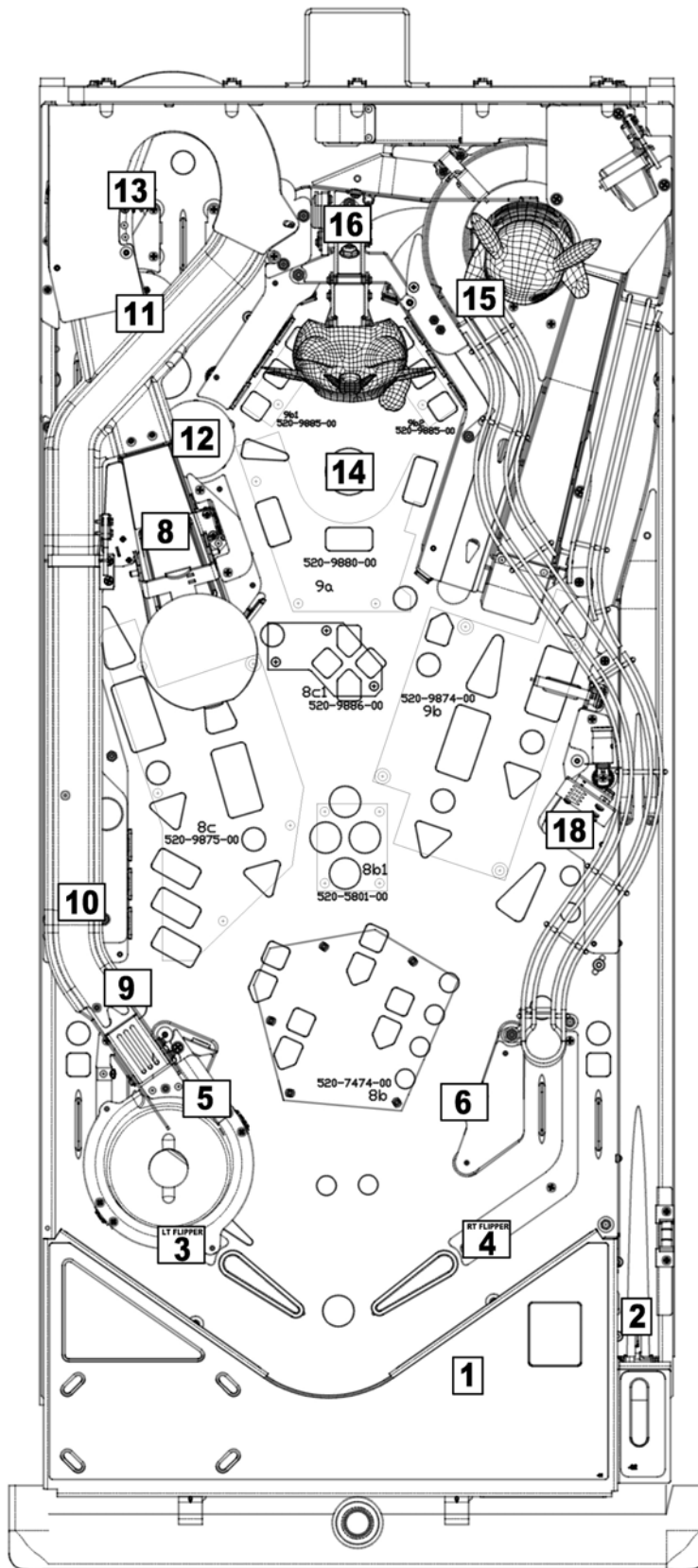

Figure 3.2.1. Playfield driver locations (top view).

### 3.3 SWITCH REFERENCE

ID	Name	Node	Node Ext	Conn.	Input Pin	Input Wire	GND Pin	Ground Wire	Location	Type	Address	Part Number
1	Left Outlane	8	-	CN11	4	LGN RED	11/12	BLK ORG	Playfield	Rollover	8-SW-17	500-2567-04
2	Left Return Lane	8	-	CN11	5	LGN ORG	11/12	BLK ORG	Playfield	Rollover	8-SW-18	500-2567-04
3												
4												
5	Right Return Lane	8	-	CN11	6	LGN YEL	11/12	BLK ORG	Playfield	Rollover	8-SW-19	500-2567-04
6	Right Outlane	8	-	CN11	7	LGN BLU	11/12	BLK ORG	Playfield	Rollover	8-SW-20	500-2567-04
7	Left Slingshot	8	-	CN10	4	GRY BLU	8	BLK GRN	Playfield	Leaf	8-SW-30	180-5231-00
8	Right Slingshot	8	-	CN10	3	GRY VIO	8	BLK GRN	Playfield	Leaf	8-SW-29	180-5231-00
9	Left Flipper Button	8	-	CN9	4	GRY BRN	7	BLK GRN	Cabinet	Leaf	8-SW-25	180-5160-01
10	Right Flipper Button	8	-	CN9	3	GRY RED	7	BLK GRN	Cabinet	Leaf	8-SW-24	180-5160-01
11	Left Flipper EOS	8	-	CN10	6	GRY YEL	9	BLK GRN	Playfield	Leaf	8-SW-16	180-5149-00
12	Right Flipper EOS	8	-	CN10	5	GRY GRN	9	BLK GRN	Playfield	Leaf	8-SW-31	180-5149-00
13												
14												
15	Trough 6	8	8a	CN14	-	-	-	-	Playfield	Opto	8-SW-32	520-5344-00 tx 520-8516-00 rx
16	Trough 5	8	8a	CN14	-	-	-	-	Playfield	Opto	8-SW-33	520-5344-00 tx 520-8516-00 rx
17	Trough 4	8	8a	CN14	-	-	-	-	Playfield	Opto	8-SW-34	520-5344-00 tx 520-8516-00 rx
18	Trough 3	8	8a	CN14	-	-	-	-	Playfield	Opto	8-SW-35	520-5344-00 tx 520-8516-00 rx
19	Trough 2	8	8a	CN14	-	-	-	-	Playfield	Opto	8-SW-36	520-5344-00 tx 520-8516-00 rx
20	Trough 1	8	8a	CN14	-	-	-	-	Playfield	Opto	8-SW-37	520-5344-00 tx 520-8516-00 rx
21	Trough Jam	8	8a	CN14	-	-	-	-	Playfield	Opto	8-SW-38	520-5344-00 tx 520-8516-00 rx
22	Shooter Lane	8	-	CN10	2	GRY WHT	7	BLK GRN	Playfield	Micro	8-SW-28	180-5157-01
23												
24												
25	Bowl Opto	8	-	CN11	3	LGN BRN	11/12	BLK ORG	Playfield	Opto	8-SW-27	515-0215-00 tx 515-0215-01 rx
26												
27	Berry Target Left	8	-	CN12	3	WHT RED	10	BLK RED	Playfield	Leaf, Target	8-SW-9	515-9785-00-00
28	Berry Target Center	8	-	CN12	4	WHT ORG	10	BLK RED	Playfield	Leaf, Target	8-SW-10	515-9784-00-00
29	Left Ramp Enter Opto	8	-	CN12	5	WHT YEL	10	BLK RED	Playfield	Opto	8-SW-11	515-0215-00 tx 515-0215-01 rx
30	Left Ramp Made 2 Gate	8	-	CN12	6	WHT GRN	10	BLK RED	Playfield	Micro	8-SW-12	180-5087-00
31	Subway Enter	8	-	CN12	2	WHT BRN	10	BLK RED	Playfield	Opto	8-SW-8	515-0215-00 tx 515-0215-01 rx
32												
33	Lower Left Target-Top	8	-	CN13	2	PNK RED	10	BLK BRN	Playfield	Leaf, Target	8-SW-0	515-9783-00-00
34	Lower Left Target-Mid	8	-	CN13	3	PNK ORG	10	BLK BRN	Playfield	Leaf, Target	8-SW-1	515-9783-00-00
35	Lower Left Target-Bot	8	-	CN13	4	PNK YEL	10	BLK BRN	Playfield	Leaf, Target	8-SW-2	515-9783-00-00
36	Lower Right Target-Top	8	-	CN13	5	PNK GRN	10	BLK BRN	Playfield	Leaf, Target	8-SW-3	515-9783-00-00
37	Lower Right Target-Bot	8	-	CN13	6	PNK BLU	10	BLK BRN	Playfield	Leaf, Target	8-SW-4	515-9783-00-00

Continued on next page...

## SWITCH REFERENCE CONTINUED

ID	Name	Node	Node Ext	Conn.	Input Pin	Input Wire	GND Pin	Ground Wire	Location	Type	Address	Part Number
38												
39												
40	Left Eject Opto	8	-	CN13	7	PNK VIO	10	BLK BRN	Playfield	Opto	8-SW-5	511-5815-00 tx 511-5815-01 rx
41	Right Eject	9	-	CN13	3	PNK ORG	10	BLK BRN	Playfield	Micro	9-SW-1	180-5209-00
42												
43												
44	Left Orbit	9	-	CN12	2	WHT BRN	10	BLK WHT	Playfield	Rollover	9-SW-8	500-2567-04
45	Left Ramp Made 1 Opto	9	-	CN12	3	WHT RED	10	BLK WHT	Playfield	Opto	9-SW-9	515-0215-00 tx 515-0215-01 rx
46	Rear Ramp Made	9	-	CN10	3	GRY BRN	7/8/9	BLK BLU	Playfield	Micro	9-SW-29	180-5087-00
47												
48												
49	Arena Left 10 Pt Sw	9	-	CN12	7	WHT BLU	10	BLK WHT	Playfield	Leaf	9-SW-13	180-5231-00
50	Arena Right 10 Pt Switch	9	-	CN12	8	WHT VIO	10	BLK WHT	Playfield	Leaf	9-SW-14	180-5231-00
51	(B)ATTLE Target	9	-	CN11	2	TAN BLK	11/12	BLK GRY	Playfield	Leaf, Target	9-SW-26	515-9783-00-00
52	B(A)TTLE Target	9	-	CN11	3	TAN RED	11/12	BLK GRY	Playfield	Leaf, Target	9-SW-27	515-9783-00-00
53	BA(T)TLE Target	9	-	CN11	4	TAN ORG	11/12	BLK GRY	Playfield	Leaf, Target	9-SW-17	515-9783-00-00
54	BAT(T)LE Target	9	-	CN11	5	TAN YEL	11/12	BLK GRY	Playfield	Leaf, Target	9-SW-18	515-9783-00-00
55	BATT(L)E Target	9	-	CN11	6	TAN GRN	11/12	BLK GRY	Playfield	Leaf, Target	9-SW-19	515-9783-00-00
56	BATTL(E) Target	9	-	CN11	7	TAN BLU	11/12	BLK GRY	Playfield	Leaf, Target	9-SW-20	515-9783-00-00
57	Team Rocket Target Left	9	-	CN11	8	TAN VIO	11/12	BLK GRY	Playfield	Leaf, Target	9-SW-21	515-9785-00-00
58	Team Rocket Target Right	9	-	CN11	9	TAN WHT	11/12	BLK GRY	Playfield	Leaf, Target	9-SW-22	515-9785-00-00
59	Meowth Hit Opto	9	-	CN11	10	TAN	11/12	BLK GRY	Playfield	Opto	9-SW-23	520-8069-00 tx 520-8068-00 rx
60	Meowth Up	9	-	CN9	3	LGN ORG	7/8	BLK BLU	Playfield	Magnet Switch	9-SW-24	520-8470-00
61	Meowth Down	9	-	CN9	4	LGN YEL	7/8	BLK BLU	Playfield	Magnet Switch	9-SW-25	520-8470-00
62												
63	Top Pop Bumper	9	-	CN10	2	GRY BLK	7/8/9	BLK BLU	Playfield	Leaf	9-SW-28	180-5232-00
64	Bot Pop Bumper	9	-	CN10	4	GRY RED	7/8/9	BLK BLU	Playfield	Leaf	9-SW-30	180-5232-00
65												
66	Top Lane Left	9	-	CN12	4	WHT ORG	10	BLK WHT	Playfield	Rollover	9-SW-10	500-2567-04
67	Top Lane Right	9	-	CN12	5	WHT YEL	10	BLK WHT	Playfield	Rollover	9-SW-11	500-2567-04
68												
69												
70	Berry Target Right	9	-	CN13	2	PNK RED	10	BLK BRN	Playfield	Leaf, Target	9-SW-0	515-9785-00-00
71	Captive Ball-Lower	9	-	CN13	6	PNK BLU	10	BLK BRN	Playfield	Rollover	9-SW-4	180-5178-00
72	Captive Ball-Upper	9	-	CN13	7	PNK VIO	10	BLK BRN	Playfield	Rollover	9-SW-5	500-2567-04
73	Captive Ball-Target	9	-	CN13	8	PNK GRY	10	BLK BRN	Playfield	Leaf, Target	9-SW-6	515-9785-00-00
74	Right Ramp Hold	9	-	CN12	9	WHT GRY	10	BLK WHT	Playfield	Micro	9-SW-15	180-5183-00
75												

Continued on next page...



SWITCH REFERENCE CONTINUED

ID	Name	Node	Node Ext	Conn.	Input Pin	Input Wire	GND Pin	Ground Wire	Location	Type	Address	Part Number
76	Right Ramp Made Opto	9	-	CN10	5	GRY ORG	7/8/9	BLK BLU	Playfield	Opto	9-SW-31	515-0215-00 tx 511-5815-01 (520-8116-00w/ cable)
77												
78	Spinner Opto	9	-	CN13	9	PNK WHT	10	BLK BRN	Playfield	Opto	9-SW-7	511-2785-01
79	Team Rocket Enter	9	-	CN13	4	PNK YEL	10	BLK BRN	Playfield	Rollover	9-SW-2	500-2567-04
80	Right Orbit	9	-	CN13	5	PNK GRN	10	BLK BRN	Playfield	Rollover	9-SW-3	500-2567-03
81												
82												
83												
84												
85												
86												
87												
88												
89												
90	Action Button	1	-	CN7	10	TAN WHT	9	BLK WHT	Cabinet	Leaf	1-SW-2	180-5218-00
91												
92												
93	Start Button	1	-	CN6	11	GRY	12	BLK WHT	Cabinet	Micro	1-SW-11	500-1060-44-LED
94	Tournament Start Button	1	-	CN6	9	-	5	-	Cabinet	Micro	1-SW-12	
95												
96	Left Coin	1	-	CN5	9	PNK BRN	3	BLK	Coin Door	Micro	1-SW-16	
97	Right Coin	1	-	CN5	7	PNK ORG	3	BLK	Coin Door	Micro	1-SW-18	
98	Center Coin	1	-	CN5	8	PNK RED	3	BLK	Coin Door	Micro	1-SW-17	
99	Fourth Coin	1	-	CN5	6	-	-	-	Coin Door	-	1-SW-19	
100	Fifth Coin	1	-	CN5	5	-	-	-	Coin Door	-	1-SW-20	
101	Tilt Pendulum	1	-	CN6	7	WHT	5	BLK WHT	Cabinet	Plumb Bob	1-SW-14	516-0007-00
102	Sixth Coin	1	-	CN9	5	-	-	-	Cabinet	-	1-SW-21	
103	Ticket Notch	1	-	CN11	5	-	-	-	Cabinet	-	1-SW-8	
104	Slam Tilt	1	-	CN5	4	-	3	-	Cabinet	-	1-SW-22	
105	Ticket Low	1	-	CN2	2	-	1	-	Cabinet	-	1-SW-7	
106												
107												
108												
109												
110												
C9	Service Select	0	-	CN25	1	LGN GRY	11	BLK WHT	Coin Door		0-SW-8	515-1963-00
C10	Service Plus	0	-	CN25	2	LGN VIO	11	BLK WHT	Coin Door		0-SW-9	515-1963-00
C11	Service Minus	0	-	CN25	3	LGN BLU	11	BLK WHT	Coin Door		0-SW-10	515-1963-00
C12	Service Back	0	-	CN25	4	LGN BLK	11	BLK WHT	Coin Door		0-SW-11	515-1963-00
C17	Headphone Detect	0	-	-	-	-	-	-	Coin Door		0-SW-16	-
C18	Headphone Kit Cable Detect	0	-	CN3	5	BLK	4	BLK	Coin Door		0-SW-17	-
C19	Volume Encoder 1	0	-	CN3	6	WHT	1	DRAIN	Coin Door		0-SW-18	-
C20	Volume Encoder 2	0	-	CN3	7	GRN	1	DRAIN	Coin Door		0-SW-19	-
C21	Jumper LVDS Resolution 1	0	-	-	-	-	-	-	CPU Node		0-SW-20	-
C22	Jumper LVDS Resolution 2	0	-	-	-	-	-	-	CPU Node		0-SW-21	-
C23	Jumper Unused	0	-	-	-	-	-	-	CPU Node		0-SW-22	-
C24	Coin Door Power Interlock	0	a	CN4	1	WHT GRY	4	BLK WHT	Cabinet		0-SW-23	-

Continued on next page...



SWITCH REFERENCE CONTINUED

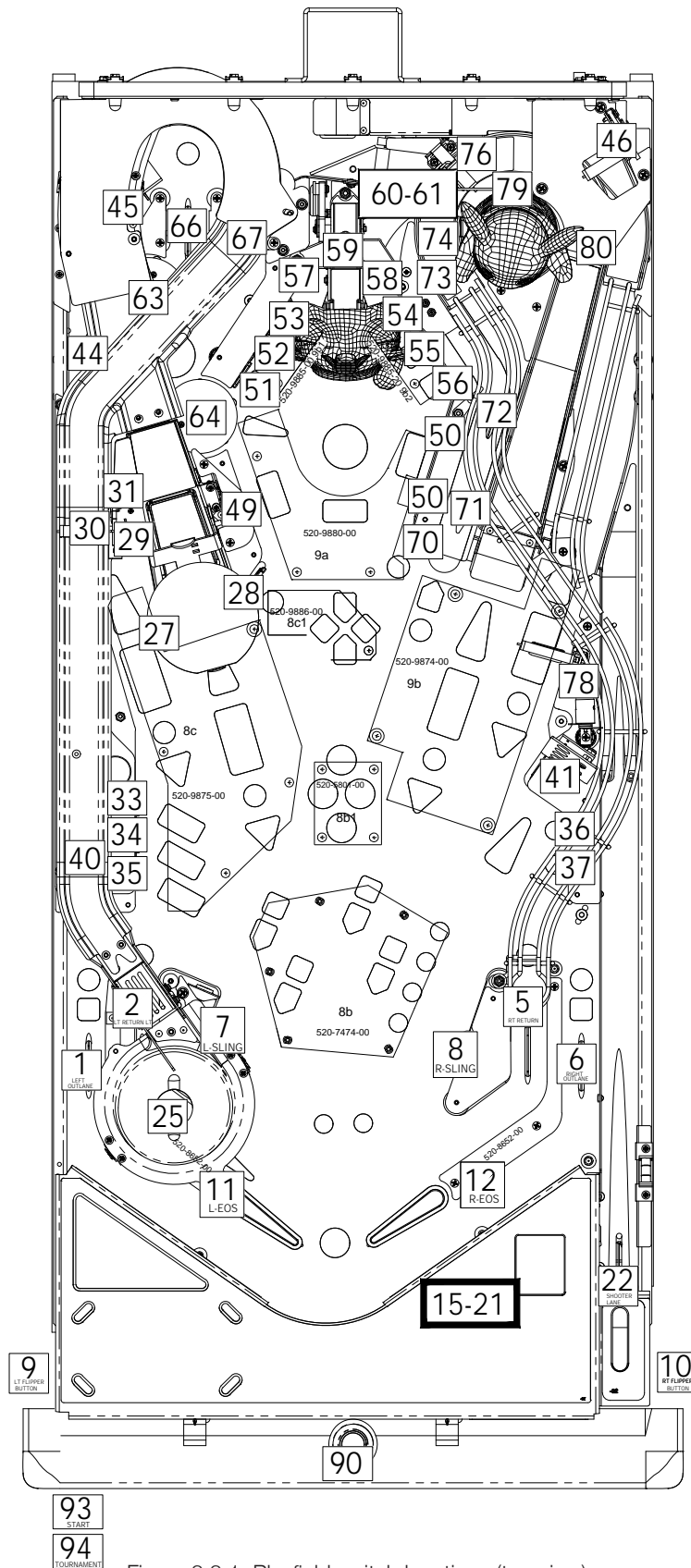

Figure 3.3.1. Playfield switch locations (top view).

### 3.4 LIGHT REFERENCE

ID	Name	Node	Node Ext.	Conn.	Ret. Pin	Ret. Wire	Src. Pin	Src. Wire	Location	Type	Light Color	Address	Part Number
1	Coin Enable	1	-	CN8	6	BLK GRY	2	GRY RED	Coin Door	Digital Out		1-LP-0	
2	Start Button	1	-	CN6	3	YEL BRN	1	RED	Cabinet	Feature	White	1-LP-2	113-5071-00
3	Tournament Start	1	-	CN6	2	YEL RED	1	RED	Cabinet	Feature	White	1-LP-3	112-5031-01
4	Action Button-R	1	-	CN7	2	RED WHT	1	RED	Cabinet	Feature	RGB	1-LP-5	520-5333-00
5	Action Button-G	1	-	CN7	3	GRN WHT	1	RED	Cabinet	Feature	RGB	1-LP-4	520-5333-00
6	Action Button-B	1	-	CN7	4	BLU WHT	1	RED	Cabinet	Feature	RGB	1-LP-7	520-5333-00
7													
8													
9													
10													
11	Left Ball Save	8	c	CN4	5	BRN ORG	1/2/3	RED	Playfield	Feature	White	8-LP-84	520-5307-00
12	Right Ball Save	8	b	CN5	4	BLU RED	1/2/3	RED	Playfield	Feature	White	8-LP-31	520-5307-00
13	(T)EAM	8	c	CN4	4	BRN RED	1/2/3	RED	Playfield	Feature	White	8-LP-83	520-5307-00
14	T(E)AM	8	c	CN4	6	BRN YEL	1/2/3	RED	Playfield	Feature	White	8-LP-85	520-5307-00
15	TE(A)M	8	b	CN1	4	YEL BLU	1/2	RED	Playfield	Feature	White	8-LP-11	520-5307-00
16	TEA(M)	8	b	CN5	5	BLU ORG	1/2/3	RED	Playfield	Feature	White	8-LP-32	520-5307-00
17	Electric Hurry Up	8	b	CN4	5	YEL VIO	1/2/3	RED	Playfield	Feature	White	8-LP-30	520-5307-00
18	Shoot Again	8	b	CN4	4	YEL RED	1/2/3	RED	Playfield	Feature	White	8-LP-29	520-5307-00
19													
20													
21													
22													
23													
24													
25													
26													
27													
28													
29													
30													
31													
32													
33													
34	Pikachu Cheek L	8	b	CN5	13	BRN VIO	1/2/3	RED	Playfield	Feature	White	8-LP-40	520-5307-00
35	Pikachu Cheek R	8	b	CN5	14	BRN GRY	1/2/3	RED	Playfield	Feature	White	8-LP-41	520-5307-00
36	Forest Rival	8	b	LED9	-	-	-	-	Playfield	Feature	White	8-LP-16	520-7474-00
37	Forest	8	b	LED19	-	-	-	-	Playfield	Feature	White	8-LP-26	520-7474-00
38	Lake Rival	8	b	LED20	-	-	-	-	Playfield	Feature	White	8-LP-27	520-7474-00
39	Lake	8	b	LED21	-	-	-	-	Playfield	Feature	White	8-LP-28	520-7474-00
40	Mountain Rival	8	b	LED1	-	-	-	-	Playfield	Feature	White	8-LP-8	520-7474-00
41	Mountain	8	b	LED2	-	-	-	-	Playfield	Feature	White	8-LP-9	520-7474-00
42	Desert Rival	8	b	LED38	-	-	-	-	Playfield	Feature	White	8-LP-45	520-7474-00
43	Desert	8	b	LED36	-	-	-	-	Playfield	Feature	White	8-LP-43	520-7474-00
44													
45	Discover	8	b	LED40	-	-	-	-	Playfield	Feature	White	8-LP-47	520-7474-00
46	Catch	8	b	LED39	-	-	-	-	Playfield	Feature	White	8-LP-46	520-7474-00
47	Train	8	b	LED37	-	-	-	-	Playfield	Feature	White	8-LP-44	520-7474-00
48	Battle	8	b	LED35	-	-	-	-	Playfield	Feature	White	8-LP-42	520-7474-00
49	Pikachu Vs Charizard	8	b	CN1	6	ORG RED	1/2	RED	Playfield	Feature	White	8-LP-13	520-5801-00
50	Pikachu Vs Lucario	8	b	CN1	7	ORG YEL	1/2	RED	Playfield	Feature	White	8-LP-14	520-5801-00
51	Pokémon Arena	8	b	CN1	5	ORG BRN	1/2	RED	Playfield	Feature	White	8-LP-12	520-5801-00

Continued on next page...



# LIGHT, SWITCH, AND DRIVER REFERENCE

## LIGHT REFERENCE CONTINUED

ID	Name	Node	Node Ext.	Conn.	Ret. Pin	Ret. Wire	Src. Pin	Src. Wire	Location	Type	Light Color	Address	Part Number
52	Pokémon Master	8	b	CN1	8	ORG GRN	1/2	RED	Playfield	Feature	White	8-LP-15	520-5801-00
53	Training 1-R	8	c	LED1	-	-	-	-	Playfield	Feature	RGB	8-LP-48	520-9875-00
54	Training 1-G	8	c	LED1	-	-	-	-	Playfield	Feature	RGB	8-LP-49	520-9875-00
55	Training 1-B	8	c	LED1	-	-	-	-	Playfield	Feature	RGB	8-LP-50	520-9875-00
56	Training 2-R	8	c	LED2	-	-	-	-	Playfield	Feature	RGB	8-LP-51	520-9875-00
57	Training 2-G	8	c	LED2	-	-	-	-	Playfield	Feature	RGB	8-LP-52	520-9875-00
58	Training 2-B	8	c	LED2	-	-	-	-	Playfield	Feature	RGB	8-LP-53	520-9875-00
59	Training 3-R	8	c	LED3	-	-	-	-	Playfield	Feature	RGB	8-LP-54	520-9875-00
60	Training 3-G	8	c	LED3	-	-	-	-	Playfield	Feature	RGB	8-LP-55	520-9875-00
61	Training 3-B	8	c	LED3	-	-	-	-	Playfield	Feature	RGB	8-LP-56	520-9875-00
62													
63	Town Target Top	9	b	CN4	6	YEL BLU	1	RED	Playfield	Feature	White	9-LP-63	520-5307-00
64	Town Target Bottom	9	b	CN4	7	YEL VIO	1	RED	Playfield	Feature	White	9-LP-64	520-5307-00
65	Town-R	8	b	CN5	9	RED WHT	1/2/3	RED	Playfield	Feature	RGB	8-LP-36	520-5333-00
66	Town-G	8	b	CN5	10	GRN WHT	1/2/3	RED	Playfield	Feature	RGB	8-LP-37	520-5333-00
67	Town-B	8	b	CN5	11	BLU WHT	1/2/3	RED	Playfield	Feature	RGB	8-LP-38	520-5333-00
68	Town Billboard 1	9	b	CN4	2	YEL BRN	1	RED	Playfield	Feature	White	9-LP-59	520-1076-00
69	Town Billboard 2	9	b	CN4	3	YEL RED	1	RED	Playfield	Feature	White	9-LP-60	520-1076-00
70	Town Billboard 3	9	b	CN4	4	YEL ORG	1	RED	Playfield	Feature	White	9-LP-61	520-1076-00
71	Town Billboard 4	9	b	CN4	5	YEL GRN	1	RED	Playfield	Feature	White	9-LP-62	520-1076-00
72													
73	Left Orbit-R	8	c	LED7	-	-	-	-	Playfield	Feature	RGB	8-LP-62	520-9875-00
74	Left Orbit-G	8	c	LED7	-	-	-	-	Playfield	Feature	RGB	8-LP-63	520-9875-00
75	Left Orbit-B	8	c	LED7	-	-	-	-	Playfield	Feature	RGB	8-LP-64	520-9875-00
76	Bulbasaur	8	c	LED6	-	-	-	-	Playfield	Feature	White	8-LP-61	520-9875-00
77	Left Orbit Combo-R	8	c	LED5	-	-	-	-	Playfield	Feature	RGB	8-LP-58	520-9875-00
78	Left Orbit Combo-G	8	c	LED5	-	-	-	-	Playfield	Feature	RGB	8-LP-59	520-9875-00
79	Left Orbit Combo-B	8	c	LED5	-	-	-	-	Playfield	Feature	RGB	8-LP-60	520-9875-00
80	Left Orbit Shot X	8	c	LED4	-	-	-	-	Playfield	Feature	White	8-LP-57	520-9875-00
81													
82	Berry Target Left-R	8	c	LED8	-	-	-	-	Playfield	Feature	RGB	8-LP-65	520-9875-00
83	Berry Target Left-G	8	c	LED8	-	-	-	-	Playfield	Feature	RGB	8-LP-66	520-9875-00
84	Berry Target Left-B	8	c	LED8	-	-	-	-	Playfield	Feature	RGB	8-LP-67	520-9875-00
85	Left Ramp-R	8	c	LED9	-	-	-	-	Playfield	Feature	RGB	8-LP-68	520-9875-00
86	Left Ramp-G	8	c	LED9	-	-	-	-	Playfield	Feature	RGB	8-LP-69	520-9875-00
87	Left Ramp-B	8	c	LED9	-	-	-	-	Playfield	Feature	RGB	8-LP-70	520-9875-00
88	Squirtle	8	c	LED17	-	-	-	-	Playfield	Feature	White	8-LP-78	520-9875-00
89	Left Ramp Combo-R	8	c	LED18	-	-	-	-	Playfield	Feature	RGB	8-LP-79	520-9875-00
90	Left Ramp Combo-G	8	c	LED18	-	-	-	-	Playfield	Feature	RGB	8-LP-80	520-9875-00
91	Left Ramp Combo-B	8	c	LED18	-	-	-	-	Playfield	Feature	RGB	8-LP-81	520-9875-00
92	Left Ramp Shot X	8	c	LED19	-	-	-	-	Playfield	Feature	White	8-LP-82	520-9875-00
93													
94	Poké Ball-R	9	a	CN2	3	RED BLK	1/2	RED	Playfield	Feature	RGB	9-LP-20	520-5333-00
95	Poké Ball-G	9	a	CN2	4	GRN BLK	1/2	RED	Playfield	Feature	RGB	9-LP-21	520-5333-00
96	Poké Ball-B	9	a	CN2	5	BLU BLK	1/2	RED	Playfield	Feature	RGB	9-LP-22	520-5333-00
97	Berry Target Center-R	8	c	CN2	7	RED WHT	1/2	RED	Playfield	Feature	RGB	8-LP-75	520-9886-00
98	Berry Target Center-G	8	c	CN2	8	GRN WHT	1/2	RED	Playfield	Feature	RGB	8-LP-76	520-9886-00
99	Berry Target Center-B	8	c	CN2	9	BLU WHT	1/2	RED	Playfield	Feature	RGB	8-LP-77	520-9886-00
100	Team Rocket 1	8	c	CN2	3	GRN BRN	1/2	RED	Playfield	Feature	White	8-LP-71	520-9886-00
101	Team Rocket 2	8	c	CN2	4	GRN RED	1/2	RED	Playfield	Feature	White	8-LP-72	520-9886-00
102	Team Rocket 3	8	c	CN2	5	GRN ORG	1/2	RED	Playfield	Feature	White	8-LP-73	520-9886-00
103	Team Rocket 4	8	c	CN2	6	GRN YEL	1/2	RED	Playfield	Feature	White	8-LP-74	520-9886-00
104													

Continued on next page...



LIGHT REFERENCE CONTINUED

ID	Name	Node	Node Ext.	Conn.	Ret. Pin	Ret. Wire	Src. Pin	Src. Wire	Location	Type	Light Color	Address	Part Number
105	Berry Target Right-R	9	a	LED4	-	-	-	-	Playfield	Feature	RGB	9-LP-17	520-9880-00
106	Berry Target Right-G	9	a	LED4	-	-	-	-	Playfield	Feature	RGB	9-LP-18	520-9880-00
107	Berry Target Right-B	9	a	LED4	-	-	-	-	Playfield	Feature	RGB	9-LP-19	520-9880-00
108	Captive Ball 1-R	9	b	LED34	-	-	-	-	Playfield	Feature	RGB	9-LP-71	520-9874-00
109	Captive Ball 1-G	9	b	LED34	-	-	-	-	Playfield	Feature	RGB	9-LP-72	520-9874-00
110	Captive Ball 1-B	9	b	LED34	-	-	-	-	Playfield	Feature	RGB	9-LP-73	520-9874-00
111	Captive Ball 2-R	9	b	LED36	-	-	-	-	Playfield	Feature	RGB	9-LP-77	520-9874-00
112	Captive Ball 2-G	9	b	LED36	-	-	-	-	Playfield	Feature	RGB	9-LP-78	520-9874-00
113	Captive Ball 2-B	9	b	LED36	-	-	-	-	Playfield	Feature	RGB	9-LP-79	520-9874-00
114													
115	Right Ramp-R	9	b	LED35	-	-	-	-	Playfield	Feature	RGB	9-LP-74	520-9874-00
116	Right Ramp-G	9	b	LED35	-	-	-	-	Playfield	Feature	RGB	9-LP-75	520-9874-00
117	Right Ramp-B	9	b	LED35	-	-	-	-	Playfield	Feature	RGB	9-LP-76	520-9874-00
118	Pikachu	9	b	LED13	-	-	-	-	Playfield	Feature	White	9-LP-46	520-9874-00
119	Right Ramp Combo-R	9	b	LED2	-	-	-	-	Playfield	Feature	RGB	9-LP-33	520-9874-00
120	Right Ramp Combo-G	9	b	LED2	-	-	-	-	Playfield	Feature	RGB	9-LP-34	520-9874-00
121	Right Ramp Combo-B	9	b	LED2	-	-	-	-	Playfield	Feature	RGB	9-LP-35	520-9874-00
122	Right Ramp Shot X	9	b	LED1	-	-	-	-	Playfield	Feature	White	9-LP-32	520-9874-00
123													
124	Right Orbit-R	9	b	LED33	-	-	-	-	Playfield	Feature	RGB	9-LP-68	520-9874-00
125	Right Orbit-G	9	b	LED33	-	-	-	-	Playfield	Feature	RGB	9-LP-69	520-9874-00
126	Right Orbit-B	9	b	LED33	-	-	-	-	Playfield	Feature	RGB	9-LP-70	520-9874-00
127	Charmander	9	b	LED32	-	-	-	-	Playfield	Feature	White	9-LP-67	520-9874-00
128	Right Orbit Combo-R	9	b	LED23	-	-	-	-	Playfield	Feature	RGB	9-LP-56	520-9874-00
129	Right Orbit Combo-G	9	b	LED23	-	-	-	-	Playfield	Feature	RGB	9-LP-57	520-9874-00
130	Right Orbit Combo-B	9	b	LED23	-	-	-	-	Playfield	Feature	RGB	9-LP-58	520-9874-00
131	Right Orbit Shot X	9	b	LED12	-	-	-	-	Playfield	Feature	White	9-LP-45	520-9874-00
132													
133	Arena Pop-R	9	a	LED1	-	-	-	-	Playfield	Feature	RGB	9-LP-8	520-9880-00
134	Arena Pop-G	9	a	LED1	-	-	-	-	Playfield	Feature	RGB	9-LP-9	520-9880-00
135	Arena Pop-B	9	a	LED1	-	-	-	-	Playfield	Feature	RGB	9-LP-10	520-9880-00
136	Arena Left 10 Point-R	9	a	LED2	-	-	-	-	Playfield	Feature	RGB	9-LP-11	520-9880-00
137	Arena Left 10 Point-G	9	a	LED2	-	-	-	-	Playfield	Feature	RGB	9-LP-12	520-9880-00
138	Arena Left 10 Point-B	9	a	LED2	-	-	-	-	Playfield	Feature	RGB	9-LP-13	520-9880-00
139	Team Rocket-R	9	a	LED3	-	-	-	-	Playfield	Feature	RGB	9-LP-14	520-9880-00
140	Team Rocket-G	9	a	LED3	-	-	-	-	Playfield	Feature	RGB	9-LP-15	520-9880-00
141	Team Rocket-B	9	a	LED3	-	-	-	-	Playfield	Feature	RGB	9-LP-16	520-9880-00
142	Arena Right 10 Point-R	9	a	LED14	-	-	-	-	Playfield	Feature	RGB	9-LP-29	520-9880-00
143	Arena Right 10 Point-G	9	a	LED14	-	-	-	-	Playfield	Feature	RGB	9-LP-30	520-9880-00
144	Arena Right 10 Point-B	9	a	LED14	-	-	-	-	Playfield	Feature	RGB	9-LP-31	520-9880-00
145													
146	(B)ATTLE-R	9	b	CN2	4	RED BRN	1/2/3	RED	Playfield	Feature	RGB	9-LP-36	520-9885-00
147	(B)ATTLE-G	9	b	CN2	5	GRN BRN	1/2/3	RED	Playfield	Feature	RGB	9-LP-37	520-9885-00
148	(B)ATTLE-B	9	b	CN2	6	BLU BRN	1/2/3	RED	Playfield	Feature	RGB	9-LP-38	520-9885-00
149	B(A)TTLE-R	9	b	CN2	7	RED YEL	1/2/3	RED	Playfield	Feature	RGB	9-LP-39	520-9885-00
150	B(A)TTLE-G	9	b	CN2	8	GRN YEL	1/2/3	RED	Playfield	Feature	RGB	9-LP-40	520-9885-00
151	B(A)TTLE-B	9	b	CN2	9	BLU YEL	1/2/3	RED	Playfield	Feature	RGB	9-LP-41	520-9885-00
152	BA(T)TLE-R	9	b	CN2	10	RED VIO	1/2/3	RED	Playfield	Feature	RGB	9-LP-42	520-9885-00
153	BA(T)TLE-G	9	b	CN2	11	GRN VIO	1/2/3	RED	Playfield	Feature	RGB	9-LP-43	520-9885-00
154	BA(T)TLE-B	9	b	CN2	12	BLU VIO	1/2/3	RED	Playfield	Feature	RGB	9-LP-44	520-9885-00
155	BAT(T)LE-R	9	b	CN3	2	RED ORG	1	RED	Playfield	Feature	RGB	9-LP-47	520-9885-00
156	BAT(T)LE-G	9	b	CN3	3	GRN ORG	1	RED	Playfield	Feature	RGB	9-LP-48	520-9885-00
157	BAT(T)LE-B	9	b	CN3	4	BLU ORG	1	RED	Playfield	Feature	RGB	9-LP-49	520-9885-00

Continued on next page...

# LIGHT, SWITCH, AND DRIVER REFERENCE

## LIGHT REFERENCE CONTINUED

ID	Name	Node	Node Ext.	Conn.	Ret. Pin	Ret. Wire	Src. Pin	Src. Wire	Location	Type	Light Color	Address	Part Number
158	BATT(L)E-R	9	b	CN3	5	RED VIO	1	RED	Playfield	Feature	RGB	9-LP-50	520-9885-00
159	BATT(L)E-G	9	b	CN3	6	GRN VIO	1	RED	Playfield	Feature	RGB	9-LP-51	520-9885-00
160	BATT(L)E-B	9	b	CN3	7	BLU VIO	1	RED	Playfield	Feature	RGB	9-LP-52	520-9885-00
161	BATT(L)E-R	9	b	CN3	8	RED GRY	1	RED	Playfield	Feature	RGB	9-LP-53	520-9885-00
162	BATT(L)E-G	9	b	CN3	9	GRN GRY	1	RED	Playfield	Feature	RGB	9-LP-54	520-9885-00
163	BATT(L)E-B	9	b	CN3	10	BLU GRY	1	RED	Playfield	Feature	RGB	9-LP-55	520-9885-00
164	Team Rocket Jackpot-R	9	a	CN2	9	RED BLU	1/2	RED	Playfield	Feature	RGB	9-LP-26	520-5333-00
165	Team Rocket Jackpot-G	9	a	CN2	10	GRN BLU	1/2	RED	Playfield	Feature	RGB	9-LP-27	520-5333-00
166	Team Rocket Jackpot-B	9	a	CN2	11	BLU	1/2	RED	Playfield	Feature	RGB	9-LP-28	520-5333-00
167													
168	Pop-R	9	a	CN2	6	RED WHT	1/2	RED	Playfield	Feature	RGB	9-LP-23	520-5333-00
169	Pop-G	9	a	CN2	7	GRN WHT	1/2	RED	Playfield	Feature	RGB	9-LP-24	520-5333-00
170	Pop-B	9	a	CN2	8	BLU WHT	1/2	RED	Playfield	Feature	RGB	9-LP-25	520-5333-00
171	Top Lane Left	9	b	CN4	8	YEL GRY	1	RED	Playfield	Feature	White	9-LP-65	520-5307-00
172	Top Lane Right	9	b	CN4	9	YEL WHT	1	RED	Playfield	Feature	White	9-LP-66	520-5307-00
173													
174													
175													
176													
177	Coin Door Gl	1	-	CN5	2	YEL	1	YEL-WHT	Coin Door	G.I.	White	1-LP-1	112-5033-08
178	Bottom Gl	8	-	CN15	5	WHT BLK	1	YEL BLK	Playfield	G.I.	White	8-LP-0	520-8722-08 520-5307-00 520-8652-00
179	Bottom Arch Gl	8	-	CN15	6	RED BLK	2	YEL RED	Playfield	G.I.	White	8-LP-1	520-5307-00 520-7000-00
180													
181													
182	Top Left Gl	9	-	CN15	5	WHT BLK	1	YEL BLK	Playfield	G.I.	White	9-LP-0	520-8722-08
183	Top Right Gl	9	-	CN15	6	RED BLK	2	YEL RED	Playfield	G.I.	White	9-LP-1	520-8722-08
184	Backpanel Gl	9	-	CN15	7	BLU BLK	3	YEL BLU	Backpanel	G.I.	White	9-LP-2	520-8722-08
185													
186													
187													
188													
189	Left Eject Flash	8	c	CN4	7	BRN GRN	1/2/3	RED	Playfield	Flash	White	8-LP-86	520-7000-00
190	Lower Left Spot	8	c	CN4	8	BRN BLU	1/2/3	RED	Playfield	Flash	White	8-LP-87	113-5032-08
191	Lower Right Spot	8	b	CN1	3	YEL GRN	1/2	RED	Playfield	Flash	White	8-LP-10	113-5032-08
192	Poké Ball Spot	9	b	CN5	4	ORG RED	1/2/3	RED	Playfield	Flash	White	9-LP-80	520-7000-00
193	Spinner Flash	9	b	CN5	5	BRN YEL	1/2/3	RED	Playfield	Flash	White	9-LP-81	520-7000-00
194	Right Eject Flash	8	b	CN5	12	BRN ORG	1/2/3	RED	Playfield	Flash	Red	8-LP-39	113-5045-02
195	Meowth Balloon Spot	9	b	CN5	6	BRN GRN	1/2/3	RED	Playfield	Flash	White	9-LP-82	520-7000-00
196													
197	Top Pop Flash	9	b	CN5	10	BRN BLK	1/2/3	RED	Playfield	Flash	White	9-LP-86	520-8059-00
198	Bottom Pop Flash	9	b	CN5	9	BRN RED	1/2/3	RED	Playfield	Flash	White	9-LP-85	520-8059-00
199	Pikachu Spot	9	b	CN5	8	ORG BRN	1/2/3	RED	Playfield	Flash	White	9-LP-84	113-5045-08

Continued on next page...





### 3.5 MOTOR REFERENCE

ID	Name	Node	Node Ext.	Conn.	Ret. Pin	Ret. Wire	Src. Pin	Src. Wire	Location	Type	Light Color	Address	Part Number
1													
2													
3													
4													
5	Poké Ball	10	CN3	-	-	-	-	-	Playfield	Servo		10-DR-6	041-5148-00
6	Pikachu	10	CN4	-	-	-	-	-	Playfield	Servo		10-DR-7	041-5148-00
7													
8													
9													
10													



# SPIKE-3 CPU NODE 0 CONTINUED CONNECTORS

ID	Connector Type	Description
CN1	5-Pin .156" Header	Backbox 2-channel amplified speaker out
CN3	7-Pin .100" Header	Headphone connector
CN4	2-Pin .156" Header	Cabinet 1-channel amplified speaker out
CN5	7-Pin .100" Header	Line In/Out
CN6	34-Pin 2.00mm Header	LCD display connector
CN7	5-Pin .156" Header	48V supply from main power supply
CN8	6-Pin .100" Header	SPI Serial
CN9	USB	USB connector - for software updates, audit dumps, and expansion modules
CN10	HDMI	HDMI Out
CN11	RJ45	SPIKE node bus - To Cabinet Node 1
CN12	RJ45	SPIKE node bus - To Topper accessory kit
CN13	SD CARD	MicroSD Card Connector
CN14	5-Pin .100" Header	LCD Backlight
CN15	ETHERNET	ETHERNET connector
CN16	4-Pin .100" Header	3.3v / 5v / 12v
CN17	HDMI	HDMI-1 Mirror Display
CN18	3-Pin .156" Header	Cabinet LEDs
CN19	3-Pin .156" Header	Topper LEDs
CN20	10-Pin 1.00mm Header	DMD / Accessories
CN21	SATA Header	Camera
CN22	RJ45	SPIKE node bus - To Playfield node board
CN23	3-Pin .156" Header	Speaker LEDs
CN25	12-Pin .100" Header	Dedicated switch inputs - service, volume switches

## COMPONENTS

ID	Name
Micro SD Card (CN13)	For system SD card. Note: only to be removed if instructed to by Stern Service.

## STATUS LEDs

LED ID	Name	Color	Description
D35 [48V]	48V Supply In	Red	ON: Main system power is connected. OFF: No 48V system power. Check power supply connections, cables, and fuses.
D32 [3.3V]	3.3V Logic	Red	ON: Logic power supply is good. OFF: Logic power supply bad, call tech support.
D20 [5V]	5V Logic	Red	ON: Logic power supply is good. OFF: Logic power supply bad, call tech support.
D55 [12V]	12V Backbox Illumination	Red	ON: Back box LED power good. OFF: Backbox LED power bad, call tech support.
D5 [VA]	30V Audio	Red	ON: Audio power supply is good. OFF: Audio power supply off, call tech support.
D3 [VNB]	9V Node Bus	Red	ON: Power for node bus good. OFF: Power to node bus not detected, call tech support.
D23	CPU Heartbeat	Red	Should blink once every ~1/2 second. OFF: Processor not running, call tech support.
D67 [ACT]	MPU Status	Red	MPU Activity LED. Flashes with use of MPU, typically flicker.

## AUDIO PINOUTS

ID	Type	Pin	Description	Minimum Impedance	Max Power (RMS)	Wire Color
CN1	.156" 5-pin Header	1	Speaker Right Ground (-)	4 Ohms	-	BLK-WHT
		2	Speaker Right (+)	4 Ohms	19 W	RED-WHT
		3	n/c	-	-	
		4	Speaker Left Ground (-)	4 Ohms	-	BLK-RED
		5	Speaker Left (+)	4 Ohms	19 W	RED-BLK
CN3	.100" 7-pin Header	1	n/c	-	-	
		2	L-HP	16 Ohms	30 mW	
		3	R-HP	16 Ohms	30 mW	
		4	n/c	-	-	
		5	Headphone Detect	-	-	
		6	Headphone vol +	-	-	
		7	Headphone vol -	-	-	
CN4	.156" 2-pin Header	1	Woofer Ground (-)	6 Ohms	-	YEL-BLK
		2	Woofer Out (+)	6 Ohms	50 W	YEL-WHT
CN5	.100" 7-pin Header	1	n/c	-	-	
		2	n/c	-	-	
		3	n/c	-	-	
		4	n/c	-	-	
		5	L-OUT	10k Ohms	1.95 V	
		6	R-OUT	10k Ohms	1.95 V	
		7	n/c	-	-	

## BACK BOX WIRING

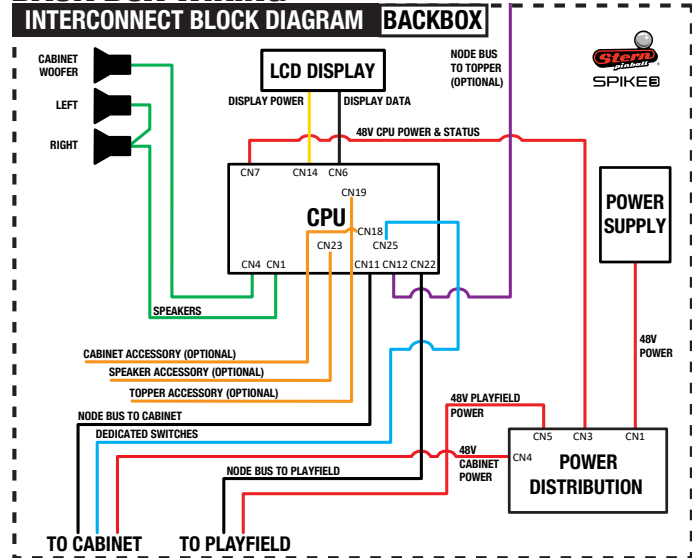

Figure 4.1.2. SPIKE 3 Back box wiring block diagram.

## COIN DOOR SERVICE SWITCH WIRING

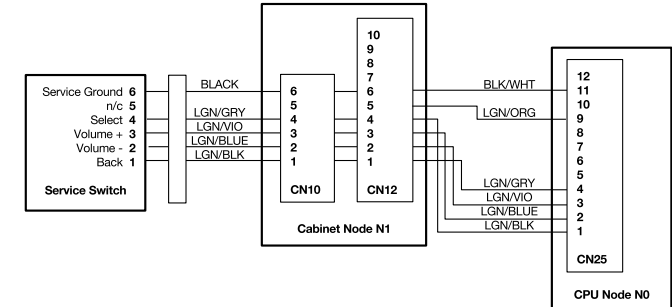

Figure 4.1.3. Service switch wiring. Note that the Cabinet Node must be present and CN10 and CN12 connected for the Coin Door Service Switches to function correctly.



# 4.2 CABINET NODE 1

520-6967-72

ID	Type	Pin	Description	Wire Color
CN1	.100" 8-Pin Header Universal Card Link	1	12V	-
		2	Coin 1	-
		3	Meter 1	-
		4	N/C	-
		5	Notch	-
		6	Coin Enable	-
		7	Ticket Enable	-
		8	Ground	-
CN2	.100" 5-Pin Header low ticket	1	Ground	-
		2	Ticket Low sw.	-
		3	Key	-
		4	Ticket Low	-
		5	5V Out	-
CN3	.100" 3-Pin Header Meter 1	1	Meter 12V (+)	RED
		2	Meter (-)	BLK
		3	N/C	-
CN4	.100" 3-Pin Header Meter 2	1	Meter 12V (+)	RED
		2	Meter (-)	BLK
		3	N/C	-
CN5	.100" 9-Pin Header	1	5V Out	YEL/WHT
		2	Coin LED Out	YEL
		3	Ground	BLK
		4	Slam Tilt In	LGN/RED
		5	Coin 5	PNK/GRN*
		6	Coin 4	PNK/YEL*
		7	Coin 3	PNK/ORN*
		8	Coin 2	PNK/RED*
		9	Coin 1	PNK/BRN*
CN6	.100" 14-Pin Header Cabinet Left	1	5V LED Power	RED
		2	Start 2 LED	-
		3	Start 1 LED	YEL-BRN
		4	Spare LED	-
		5	Ground	BLK-WHT
		6	Spare Left	-
		7	Tilt Input	WHT
		8	Door Open	-
		9	Start 2 Switch [Tournament]	-
		10	Start 1 Switch	-
		11	Flip Left 2 [Start Signal]	GRY
		12	Flip Left 1 [Start Ground]	BLK-WHT
		13	CTRL RTN	-
		14	N/C	-
CN7	.100" 12-Pin Header Cabinet Right	1	5V LED Power	RED
		2	Plunge 2 LED	RED-WHT
		3	Plunge 1 LED	GRN-WHT
		4	Spare LED 2	BLU-WHT
		5	Ground	-
		6	Spare Right In	-
		7	Plunge 2 Switch	-
		8	Plunge 1 Switch	-
		9	Flip Right 2 [Action Ground]	BLK-WHT
		10	Flip Right 1 [Action Signal]	TAN-WHT
		11	CTRL RTN	-
		12	N/C	-
CN8	.100" 10-Pin Header dual row. Electronic Coin Mech	1	Ground	-
		2	12V	-
		3	Coin 5	-
		4	Coin 6	-
		5	N/C	-
		6	Coin Enable/Inhibit (+)	-
		7	Coin 1	-
		8	Coin 2	-
		9	Coin 3	-
		10	Coin 4	-

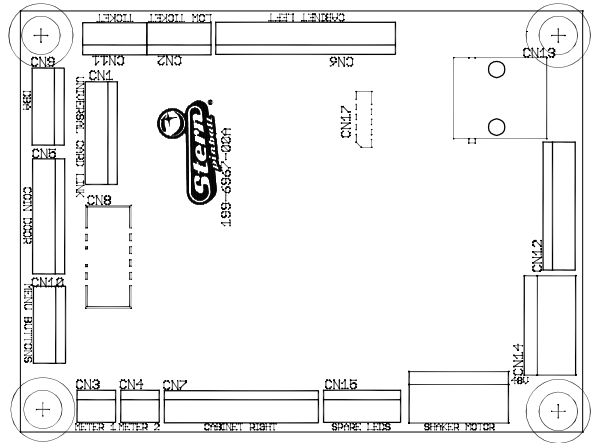

ID	Type	Pin	Description	Wire Color
CN9	.100" 6-Pin Header Dollar Bill Acceptor	1	Coin Enable/DBA Inhibit (-)	-
		2	Coin Enable/DBA Inhibit (+)	-
		3	Key	Key
		4	DBA 12V	ORG
		5	Coin 6 / DBA Credit	-
		6	Ground	BLK-ORG
CN10	.100" 6-Pin Header Service Switch In	1	Service Back (To Coindoor)	LGN-BLK
		2	Service - / Down (To Coindoor)	LGN-BLU
		3	Service + / Up (To Coindoor)	LGN-VIO
		4	Service Select (To Coindoor)	LGN-GRY
		5	Key	Key
		6	Service Ground (To Coindoor)	BLK
CN11	.100" 5-Pin Header Ticket Dispenser	1	12V	RED
		2	N/C	-
		3	Ticket Dispenser Enable	WHT
		4	Ground	BLK
		5	Ticket Dispenser Notch	BLU
CN12	.100" 10-Pin Header CPU Direct Switches	1	Service Back (To CPU)	LGN-BLK
		2	Service Down (To CPU)	LGN-BLU
		3	Service Up (To CPU)	LGN-VIO
		4	Service Select (To CPU)	LGN-GRY
		5	Power Present	LGN-ORG
		6	Service Ground (To CPU)	BLK-WHT
		7	Flip Left 2 [Start Signal]	GRY
		8	Flip Left 1 [Start Ground]	BLK-BRN
		9	Flip Right 1 [Action Signal]	TAN-WHT
		10	Flip Right 2 [Action Ground]	BLK-BRN
CN14	.156" 5-Pin Header Power Input	1	Ground	BLK
		2	Key	Key
		3	N/C	-
		4	N/C	-
		5	48VDC In	GRY-YEL
CN15	.100" 6-Pin Header Spare LED's	1	5V LED Power	-
		2	Key	Key
		3	Spare LED 3	-
		4	Spare LED 4	-
		5	Spare LED 5	-
		6	Spare LED 6	-
CN16	.156" 5-Pin Header Shaker Motor	1	Shaker Motor (-)	BLU
		2	Shaker Motor (-)	-
		3	Shaker Motor (+)	-
		4	Key	Key
		5	Shaker Motor (+)	RED
			*Varies by country model	



©2026 Pokémon. ©1995-2026 Nintendo / Creatures Inc. / GAME FREAK inc. TM, ®, and character names are trademarks of Nintendo.

# 4.3 LOWER PLAYFIELD 48V DRIVER PINOUT NODE 8

520-1070 / 520-1057-00

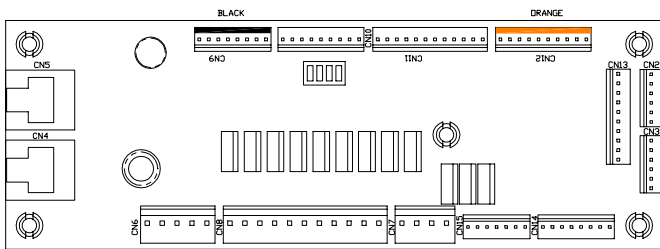

ID	Type	Pin	Description	Wire Color
SW1	Address DIP	-	Node 8 - OFF-OFF-OFF-OFF	-
CN4	RJ45	-	SPIKE Node Bus	Multi
CN5	RJ45	-	SPIKE Node Bus	Multi
CN6	.156" 5-Pin Header Node Power	1	Ground	BLK
		2	Key	Key
		3	N/C	-
		4	-	-
		5	48VDC In	GRY
CN7	.156" 4-Pin Header (White)	1	48V Driver Power	GRY-ORG
		2	8-DR-8 Driver Return	YEL-RED
		3	8-DR-6 Driver Return	YEL-BLK
		4	8-DR-7 Driver Return	YEL-BRN
CN8	.156 11-Pin Header (White)	1	48V Driver Power	GRY-ORG
		2	48V Driver Power	GRY-ORG
		3	48V Driver Power	GRY-ORG
		4	48V Driver Power	GRY-ORG
		5	8-DR-0 Driver Return	ORG-GRN
		6	8-DR-5 Driver Return	ORG-YEL
		7	8-DR-1 Driver Return	ORG-GRY
		8	8-DR-8 Driver Return	-
		9	8-DR-4 Driver Return	ORG-WHT
		10	8-DR-2 Driver Return	ORG-VIO
		11	8-DR-3 Driver Return	ORG-BLU
CN9	.100" 8-Pin Header (Black)	1	V+	-
		2	V+	-
		3	8-SW-24 Switch	GRY-RED
		4	8-SW-25 Switch	GRY-BRN
		5	8-SW-26 Switch	-
		6	8-SW-27 Switch	-
		7	Ground	BLK-GRN
		8	Ground	-
CN10	.100" 9-Pin Header (White)	1	V+	-
		2	8-SW-28 Switch	GRY-WHT
		3	8-SW-29 Switch	GRY-VIO
		4	8-SW-30 Switch	GRY-BLU
		5	8-SW-31 Switch	GRY-GRN
		6	8-SW-16 Switch	GRY-YEL
		7	Ground	BLK-GRN
		8	Ground	BLK-GRN
		9	Ground	BLK-GRN

ID	Type	Pin	Description	Wire Color
CN11	.100" 12-Pin Header (White)	1	V+	RED
		2	8-SW-26 Switch	-
		3	8-SW-27 Switch	LGN-BRN
		4	8-SW-17 Switch	LGN-RED
		5	8-SW-18 Switch	LGN-ORG
		6	8-SW-19 Switch	LGN-YEL
		7	8-SW-20 Switch	LGN-BLU
		8	8-SW-21 Switch	-
		9	8-SW-22 Switch	-
		10	8-SW-23 Switch	-
		11	Ground	BLK-ORG
		12	Ground	BLK-ORG
CN12	.100" 10-Pin Header (Orange)	1	V+	RED
		2	8-SW-8 Switch	WHT-BRN
		3	8-SW-9 Switch	WHT-RED
		4	8-SW-10 Switch	WHT-ORG
		5	8-SW-11 Switch	WHT-YEL
		6	8-SW-12 Switch	WHT-GRN
		7	8-SW-13 Switch	-
		8	8-SW-14 Switch	-
		9	8-SW-15 Switch	-
		10	Ground	BLK-RED
CN13	.100" 10-Pin Header	1	V+	RED
		2	8-SW-0 Switch	PNK-RED
		3	8-SW-1 Switch	PNK-ORG
		4	8-SW-2 Switch	PNK-YEL
		5	8-SW-3 Switch	PNK-GRN
		6	8-SW-4 Switch	PNK-BLU
		7	8-SW-5 Switch	-
		8	8-SW-6 Switch	-
		9	8-SW-7 Switch	-
		10	Ground	BLK-BRN
CN15	.100" 7-Pin Header (White)	1	LED V+	YEL-BLK
		2	LED V+	YEL-RED
		3	LED V+	-
		4	-	-
		5	8-LP-0 GI Return	WHT-BLK
		6	8-LP-1 GI Return	RED-BLK
		7	8-LP-2 GI Return	-
CN2	.100" 6-Pin Header, Node Extension Bus	1	Ground	BLK
		2	DIN	VIO-BLK
		3	DOUT	VIO-BRN
		4	SCK	VIO-RED
		5	RCK	VIO-ORG
		6	V+	RED
CN3	.100" 6-Pin Header, Node Extension Bus	1	Ground	BLK
		2	DIN	VIO-BLK
		3	DOUT	VIO-BRN
		4	SCK	VIO-RED
		5	RCK	VIO-ORG
		6	V+	RED



# 4.4 MID UPPER PLAYFIELD 48V DRIVER PINOUT NODE 9

520-1070 / 520-1057-00

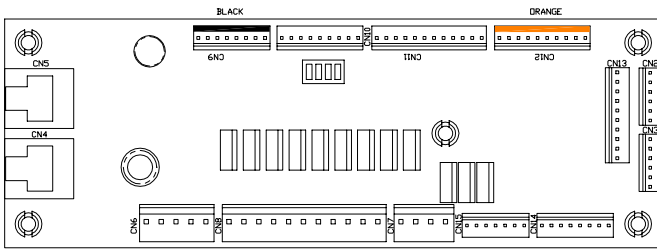

ID	Type	Pin	Description	Wire Color
SW1	Address DIP	-	Node 9 - OFF-OFF-ON-OFF	-
CN4	RJ45	-	SPIKE Node Bus	Multi
CN5	RJ45	-	SPIKE Node Bus	Multi
CN6	.156" 5-Pin Header Node Power	1	Ground	BLK
		2	Key	Key
		3	N/C	-
		4	N/C	-
		5	48VDC In	GRY
CN7	.156" 4-Pin Header (White)	1	48V Driver Power	GRY-BRN
		2	9-DR-8 Driver Return	YEL-ORG
		3	9-DR-6 Driver Return	YEL-GRN
		4	9-DR-7 Driver Return	BRN-BLK
CN8	.156 11-Pin Header (White)	1	48V Driver Power	GRY-BRN
		2	48V Driver Power	GRY-BRN
		3	48V Driver Power	GRY-BRN
		4	48V Driver Power	GRY-BRN
		5	9-DR-0 Driver Return	YEL-VIO
		6	9-DR-5 Driver Return	BRN-RED
		7	9-DR-1 Driver Return	-
		8	9-DR-8 Driver Return	-
		9	9-DR-4 Driver Return	ORG-RED
		10	9-DR-2 Driver Return	ORG-BLK
		11	9-DR-3 Driver Return	-
CN9	.100" 8-Pin Header (Black)	1	V+	RED
		2	V+	-
		3	9-SW-24 Switch	LGN-ORG
		4	9-SW-25 Switch	LGN-YEL
		5	9-SW-26 Switch	-
		6	9-SW-27 Switch	-
		7	Ground	BLK-BLU
		8	Ground	-
CN10	.100" 9-Pin Header	1	V+	RED
		2	9-SW-28 Switch	GRY-BLK
		3	9-SW-29 Switch	GRY-BRN
		4	9-SW-30 Switch	GRY-RED
		5	9-SW-31 Switch	GRY-ORG
		6	9-SW-16 Switch	-
		7	Ground	BLK-BLU
		8	Ground	BLK-BLU
		9	Ground	BLK-BLU

ID	Type	Pin	Description	Wire Color
CN11	.100" 12-Pin Header	1	V+	RED
		2	9-SW-26 Switch	TAN-BLK
		3	9-SW-27 Switch	TAN-RED
		4	9-SW-17 Switch	TAN-ORG
		5	9-SW-18 Switch	TAN-YEL
		6	9-SW-19 Switch	TAN-GRN
		7	9-SW-20 Switch	TAN-BLU
		8	9-SW-21 Switch	TAN-VIO
		9	9-SW-22 Switch	TAN-WHT
		10	9-SW-23 Switch	TAN
		11	Ground	BLK-GRY
		12	Ground	BLK-GRY
CN12	.100" 10-Pin Header (Orange)	1	V+	RED
		2	9-SW-8 Switch	WHT-BRN
		3	9-SW-9 Switch	WHT-RED
		4	9-SW-10 Switch	WHT-ORG
		5	9-SW-11 Switch	WHT-YEL
		6	9-SW-12 Switch	-
		7	9-SW-13 Switch	WHT-BLU
		8	9-SW-14 Switch	WHT-VIO
		9	9-SW-15 Switch	WHT-GRY
		10	Ground	BLK-WHT
CN13	.100" 10-Pin Header	1	V+	RED
		2	9-SW-0 Switch	PNK-RED
		3	9-SW-1 Switch	PNK-ORG
		4	9-SW-2 Switch	PNK-YEL
		5	9-SW-3 Switch	PNK-GRN
		6	9-SW-4 Switch	PNK-BLU
		7	9-SW-5 Switch	PNK-VIO
		8	9-SW-6 Switch	PNK-GRY
		9	9-SW-7 Switch	PNK-WHT
		10	Ground	BLK-BRN
CN15	.100" 7-Pin Header	1	LED V+	YEL-BLK
		2	LED V+	YEL-RED
		3	LED V+	YEL-BLU
		4	-	-
		5	9-LP-0 GI Return	WHT-BLK
		6	9-LP-1 GI Return	RED-BLK
		7	9-LP-2 GI Return	BLU-BLK
CN2	.100" 6-Pin Header, Node Extension Bus	1	Ground	BLK
		2	DIN	VIO BLK
		3	DOUT	VIO BRN
		4	SCK	VIO RED
		5	RCK	VIO ORG
		6	V+	RED
CN3	.100" 6-Pin Header, Node Extension Bus	1	Ground	-
		2	DIN	-
		3	DOUT	-
		4	SCK	-
		5	RCK	-
		6	V+	-



# 4.5 12W BC LED BOARD 8B

520-7474-00

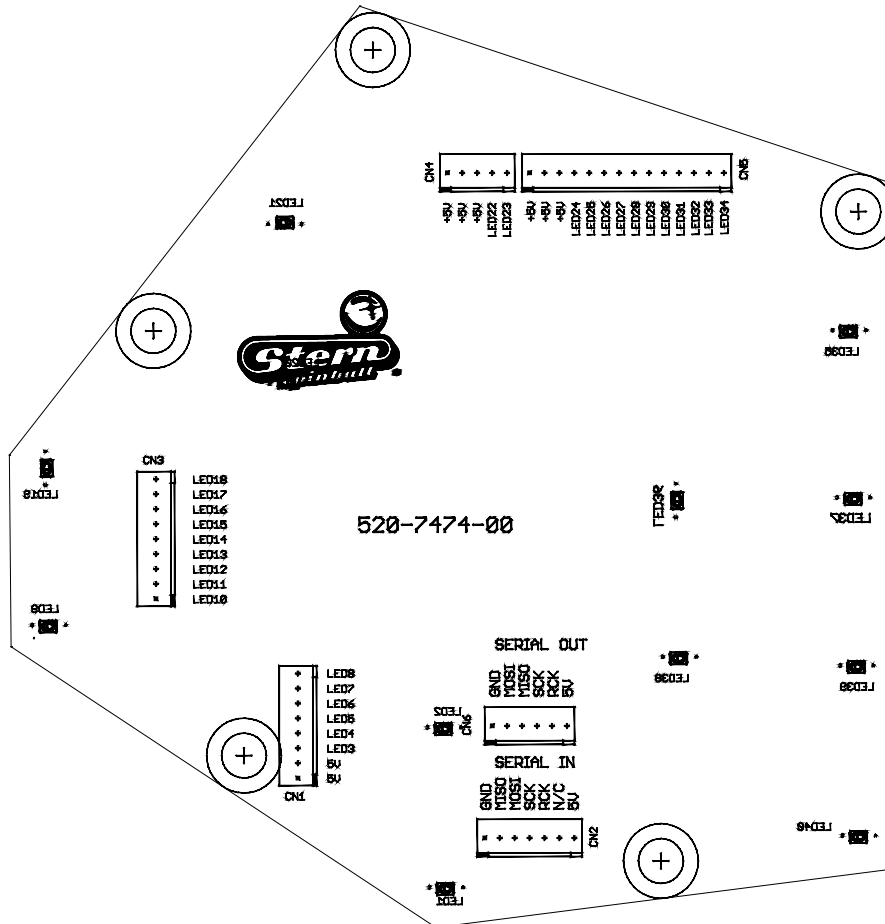

ID	Type	Pin	Description	Wire Color	
CN1	.100" 8-Pin Header	1	+5V	RED	TO 8b1
		2	+5V	RED	
		3	LED3	YEL GRN	
		4	LED4	YEL BLU	
		5	LED5	ORG BRN	TO 8b1
		6	LED6	ORG RED	TO 8b1
		7	LED7	ORG YEL	TO 8b1
		8	LED8	ORG GRN	TO 8b1
CN2	.100" 7-Pin Header	1	Ground	BLK	
		2	MISO Output Data	VIO BLK	
		3	MOSI Input Data	VIO BRN	
		4	SCK Serial Clock	VIO RED	
		5	RCK Register Clock	VIO ORG	
		6	NC	-	
		7	+5 VDC IN	RED	
CN3	.100" 9-Pin Header	1	LED10	-	
		2	LED11	-	
		3	LED12	-	
		4	LED13	-	
		5	LED14	-	
		6	LED15	-	
		7	LED16	-	
		8	LED17	-	
		9	LED18	-	

ID	Type	Pin	Description	Wire Color	
CN4	.100" 5-Pin Header	1	+5V	RED	
		2	+5V	RED	
		3	+5V	-	
		4	LED22	YEL RED	
		5	LED23	YEL VIO	
CN5	.100" 14-Pin Header	1	+5V	RED	
		2	+5V	RED	
		3	+5V	RED	
		4	LED24	BLU RED	
		5	LED25	BLU ORG	
		6	LED26	-	
		7	LED27	-	
		8	LED28	-	
		9	LED29	RED WHT	
		10	LED30	GRN WHT	
CN6	.100" 6-Pin Header	11	LED31	BLU WHT	
		12	LED32	BRN ORG	
		13	LED33	BRN VIO	
		14	LED34	BRN GRY	
		1	Ground	BLK	
		2	MISO Output Data	VIO BLK	
3	MOSI Input Data	VIO BRN			
4	SCK Serial Clock	VIO RED			
5	RCK Register Clock	VIO ORG			
6	+5V	RED			



### 4.6 4W MC LED BOARD 8B1 520-5801-00

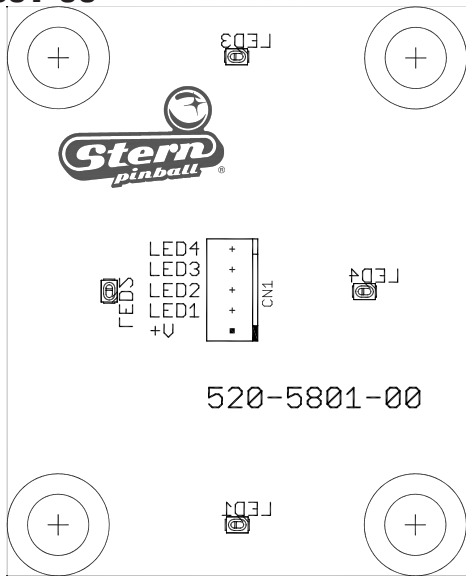

ID	Type	Pin	Description	Wire Color
CN1	.100" 5-Pin Header	1	+5V	RED
		2	LED 1	ORG BRN
		3	LED 2	ORG RED
		4	LED 3	ORG GRN
		5	LED 4	ORG YEL

### 4.7 1R 4W ML LED BOARD 8C1 520-9886-00

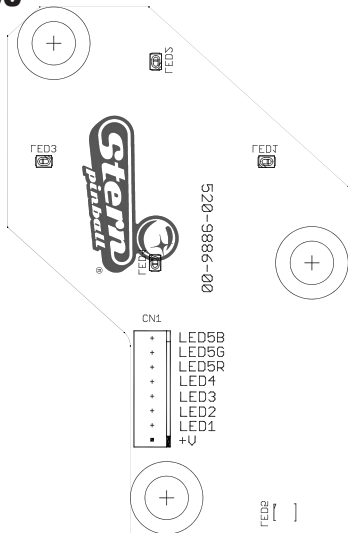

ID	Type	Pin	Description	Wire Color
CN1	.100" 8-Pin Header	1	+5V	RED
		2	LED1	GRN BRN
		3	LED2	GRN YEL
		4	LED3	GRN ORG
		5	LED4	GRN RED
		6	LED5R	RED WHT
		7	LED5G	GRN WHT
		8	LED5B	BLU WHT

### 4.8 6R 4W ML LED BOARD 8C 520-9875-00

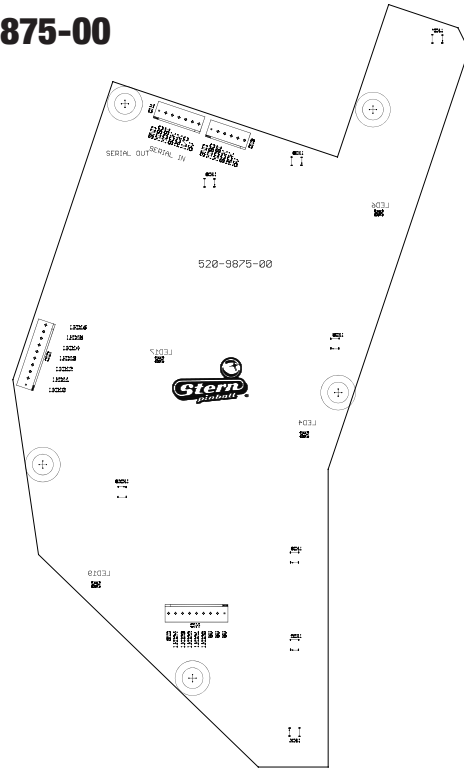

ID	Type	Pin	Description	Wire Color	
CN1	.100" 7-Pin Header	1	Ground	BLK	
		2	MISO Output Data	VIO BLK	
		3	MOSI Input Data	VIO BRN	
		4	SCK Serial Clock	VIO RED	
		5	RCK Register Clock	VIO ORG	
		6	NC	-	
		7	+5 VDC IN	RED	
CN2	.100" 10-Pin Header	1	+5V	RED	TO 8c1
		2	+5V	-	
		3	LED10	GRN BRN	TO 8c1
		4	LED11	GRN RED	TO 8c1
		5	LED12	GRN ORG	TO 8c1
		6	LED13	GRN YEL	TO 8c1
		7	LED14	RED WHT	TO 8c1
		8	LED15	GRN WHT	TO 8c1
		9	LED16	BLU WHT	TO 8c1
		10	GND	-	
CN3	.100" 5-Pin Header	1	Ground	-	
		2	MISO Output Data	-	
		3	MOSI Input Data	-	
		4	SCK Serial Clock	-	
		5	RCK Register Clock	-	
		6	+5V	-	
CN4	.100" 9-Pin Header	1	+5V	RED	
		2	+5V	RED	
		3	+5V	RED	
		4	LED20	BRN RED	
		5	LED21	BRN ORG	
		6	LED22	BRN YEL	
		7	LED23	BRN GRN	
		8	LED24	BRN BLU	
		9	GND	-	



### 4.9 5R TC LED BOARD 9A 520-9880-00

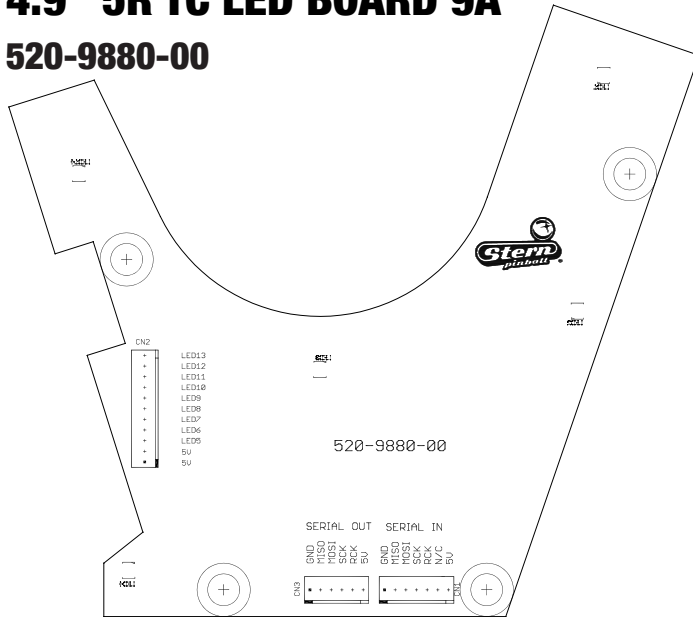

ID	Type	Pin	Description	Wire Color
CN1	.100" 7-Pin Header	1	Ground	BLK
		2	MISO Output Data	VIO-BLK
		3	MOSI Input Data	VIO-BRN
		4	SCK Serial Clock	VIO-RED
		5	RCK Register Clock	VIO-ORG
		6	NC	-
		7	+5 VDC IN	RED
CN2	.100" 10-Pin Header	1	+5V	RED
		2	+5V	RED
		3	LED5	RED BLK
		4	LED6	GRN BLK
		5	LED7	BLU BLK
		6	LED8	RED WHT
		7	LED9	GRN WHT
		8	LED10	BLU WHT
		9	LED11	RED BLU
		10	LED12	GRN BLU
		11	LED13	BLU
CN3	.100" 5-Pin Header	1	Ground	BLK
		2	MISO Output Data	VIO BLK
		3	MOSI Input Data	VIO BRN
		4	SCK Serial Clock	VIO RED
		5	RCK Register Clock	VIO ORG
		6	+5V	RED

### 4.10 TROUGH SERIAL OPTO TRANSMITTER 520-5344-00

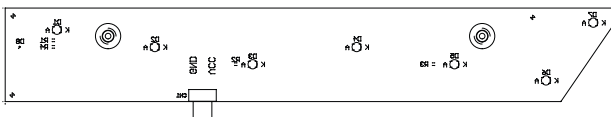

ID	Type	Pin	Description	Wire Color
CN1	.100" 3-Pin Header	1	Ground	BLK
		2	N/C	-
		3	+5 VDC IN	RED

### 4.11 3R TC LED BOARD 9B1 520-9885-00

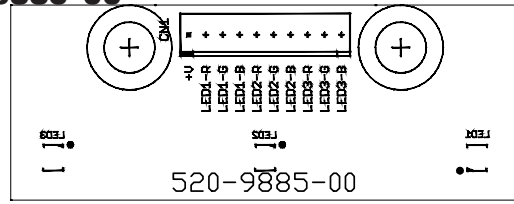

ID	Type	Pin	Description	Wire Color
CN1	.100" 10-Pin Header	1	+5V	RED
		2	LED1-R	RED VIO
		3	LED1-G	GRN VIO
		4	LED1-B	BLU VIO
		5	LED2-R	RED YEL
		6	LED2-G	GRN YEL
		7	LED2-B	BLU YEL
		8	LED3-R	RED BRN
		9	LED3-G	GRN BRN
		10	LED3-B	BLU BRN

### 4.12 3R TC LED BOARD 9B2 520-9885-00

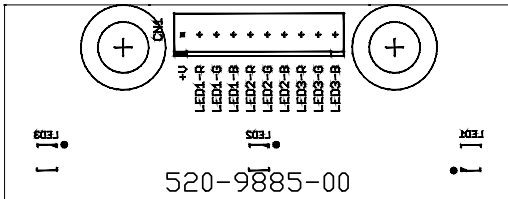

ID	Type	Pin	Description	Wire Color
CN1	.100" 10-Pin Header	1	+5V	RED
		2	LED1-R	RED GRY
		3	LED1-G	GRN GRY
		4	LED1-B	BLU GRY
		5	LED2-R	RED VIO
		6	LED2-G	GRN VIO
		7	LED2-B	BLU VIO
		8	LED3-R	RED ORG
		9	LED3-G	GRN ORG
		10	LED3-B	BLU ORG

### 4.13 BILLBOARD 4-LED BOARD 520-1076-00

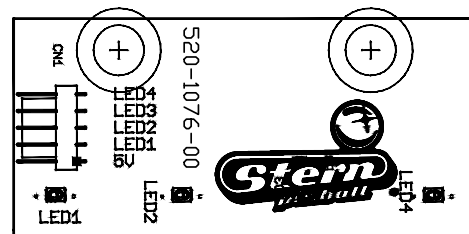

ID	Type	Pin	Description	Wire Color
CN1	.100" 5-Pin Header	1	5V	RED
		2	LED 1	YEL BRN
		3	LED 2	YEL RED
		4	LED 3	YEL ORG
		5	LED 4	YEL GRN



# 4.14 6R 4W MR LED BOARD 9B

520-9874-00

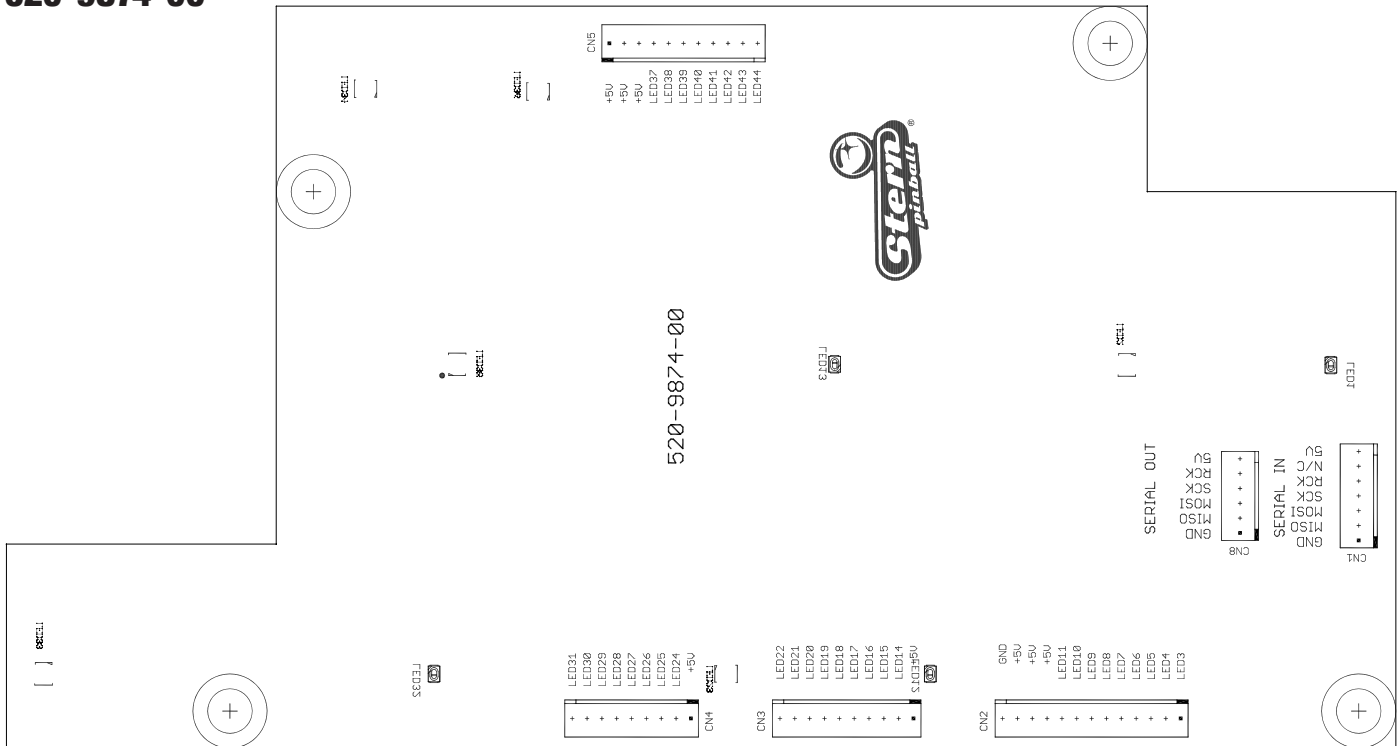

ID	Type	Pin	Description	Wire Color	
CN1	.100" 7-Pin Header	1	Ground	BLK	
		2	MISO Output Data	VIO-BLK	
		3	MOSI Input Data	VIO-BRN	
		4	SCK Serial Clock	VIO-RED	
		5	RCK Register Clock	VIO-ORG	
		6	NC	-	
		7	+5 VDC IN	RED	
CN2	.100" 13-Pin Header	1	+5V	RED	TO 9b1
		2	+5V	-	
		3	+5V	-	
		4	LED 3	RED-BRN	TO 9b1
		5	LED 4	GRN-BRN	TO 9b1
		6	LED 5	BLU-BRN	TO 9b1
		7	LED 6	RED-YEL	TO 9b1
		8	LED 7	GRN-YEL	TO 9b1
		9	LED 8	BLU-YEL	TO 9b1
		10	LED 9	RED-VIO	TO 9b1
		11	LED 10	GRN-VIO	TO 9b1
		12	LED 11	BLU-VIO	TO 9b1
		13	GND	BLK	
CN3	.100" 10-Pin Header	1	+5V	RED	TO 9b2
		2	LED 14	RED-ORG	TO 9b2
		3	LED 15	GRN-ORG	TO 9b2
		4	LED 16	BLU-ORG	TO 9b2
		5	LED 17	RED-VIO	TO 9b2
		6	LED 18	GRN-VIO	TO 9b2
		7	LED 19	BLU-VIO	TO 9b2
		8	LED 20	RED-GRY	TO 9b2
		9	LED 21	GRN-GRY	TO 9b2
		10	LED 22	BLU-GRY	TO 9b2

ID	Type	Pin	Description	Wire Color	
CN4	.100" 9-Pin Header	1	+5V	RED	
		2	LED 24	YEL-BRN	
		3	LED 25	YEL-RED	
		4	LED 26	YEL-ORG	
		5	LED 27	YEL-GRN	
		6	LED 28	YEL-BLU	
		7	LED 29	YEL-VIO	
		8	LED 30	YEL-GRY	
		9	LED 31	YEL-WHT	
CN5	.100" 11-Pin Header	1	+5V	RED	
		2	+5V	RED	
		3	+5V	RED	
		4	LED 37	ORG-RED	
		5	LED 38	BRN-YEL	
		6	LED 39	BRN-GRN	
		7	LED 40	BRN-BLU	
		8	LED 41	ORG-BRN	
		9	LED 42	BRN-RED	
		10	LED 43	BRN-BLK	
		11	LED 44	-	
CN8	.100" 6-Pin Header	1	Ground	-	
		2	MISO Output Data	-	
		3	MOSI Input Data	-	
		4	SCK Serial Clock	-	
		5	RCK Register Clock	-	
		6	+5 VDC IN	-	



# 4.15 ISOLATED SMART LED PSU

520-8656-01

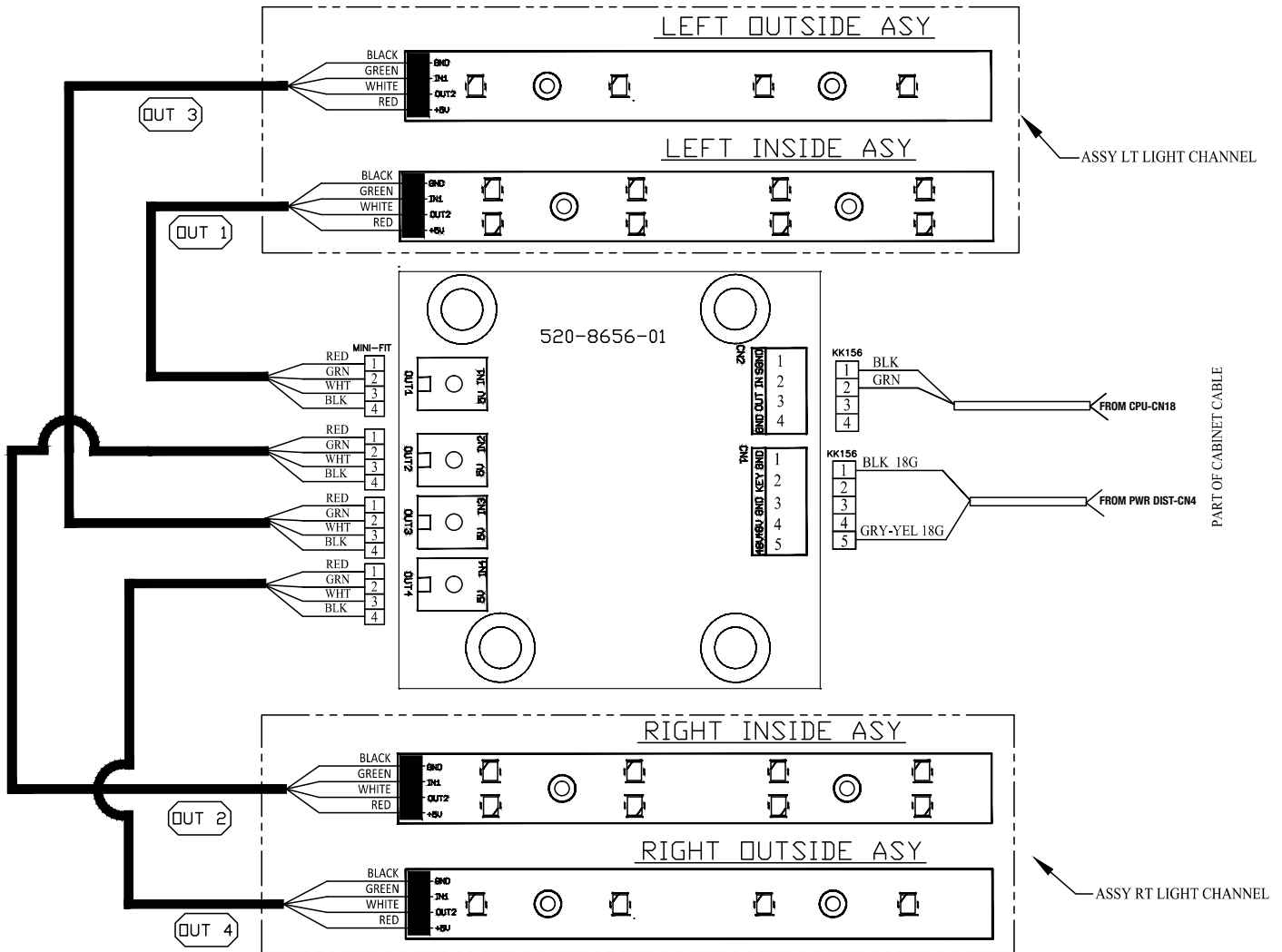

ID	Type	Pin	Description	Wire Color
CN1	.156 5-Pin Connector	1	GND	BLK
		2	KEY	Key
		3	GND	-
		4	+48 VDC IN	-
		5	+48 VDC IN	GRY
CN2	.156 4-Pin Connector	1	S-Ground	BLK
		2	SIGNAL-IN	GRN
		3	OUT	-
		4	GND	-
CN3	Mini-Fit Jr.4-Pin Connector	1	+5V	RED
		2	IN1	GRN
		3	OUT-1	WHT
		4	GND	BLK

ID	Type	Pin	Description	Wire Color
CN4	Mini-Fit Jr.4-Pin Connector	1	+5V	RED
		2	IN2	GRN
		3	OUT-2	WHT
		4	GND	BLK
CN5	Mini-Fit Jr.4-Pin Connector	1	+5V	RED
		2	IN3	GRN
		3	OUT-3	WHT
		4	GND	BLK
CN6	Mini-Fit Jr.4-Pin Connector	1	+5V	RED
		2	IN4	GRN
		3	OUT-4	WHT
		4	GND	BLK



### 4.16 SPI NODE 10 520-5370-72

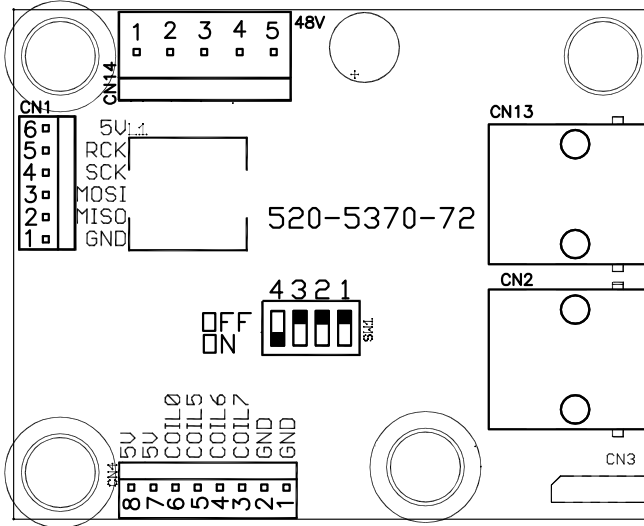

ID	Type	Pin	Description	Wire Color
SW1	Address DIP	-	Node 10 - OFF-ON-OFF-OFF	-
CN2	RJ45	-	SPIKE Node Bus	Multi
CN13	RJ45	-	SPIKE Node Bus	Multi
CN14	.156" 5-Pin Header Node Power	1	Ground	BLK
		2	Key	Key
		3	N/C	-
		4	N/C	-
		5	48VDC In	GRY
CN1	.100" 6-Pin Header, Node Extension Bus	1	Ground	-
		2	DIN	-
		3	DOUT	-
		4	SCK	-
		5	RCK	-
		6	V+	-
CN4	.100" 8-Pin Header	1	GND	520-8685-00 (J1)
		2	GND	520-8685-00 (J1)
		3	COIL 7	520-8685-00 (J1)
		4	COIL 6	520-8685-00 (J1)
		5	COIL 5	520-8685-00 (J1)
		6	COIL 0	520-8685-00 (J1)
		7	5V	520-8685-00 (J1)
		8	5V	520-8685-00 (J1)

### 4.17 MULTI-SERVO INTERFACE SPI BOARD 10A 520-8685-00

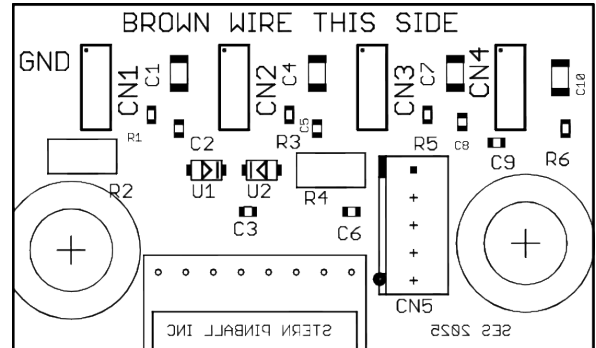

ID	Type	Pin	Description	Wire Color
CN1	2.54mm 3-Pin Header	1	GND	-
		2	5V	-
		3	SERVO-0	-
CN2	2.54mm 3-Pin Header	1	GND	-
		2	5V	-
		3	SERVO-5	-
CN3	2.54mm 3-Pin Header	1	GND	BRN
		2	5V	RED
		3	SERVO-6	YEL
CN4	2.54mm 3-Pin Header	1	GND	BRN
		2	5V	RED
		3	SERVO-7	YEL
CN5	.100" 5-Pin Header	1	AUX-5V	-
		2	AUX-5V	-
		3	N/C	-
		4	GND	-
		5	GND	-

### 4.18 TROUGH SERIAL OPTO RECEIVER 8A 520-8516-00

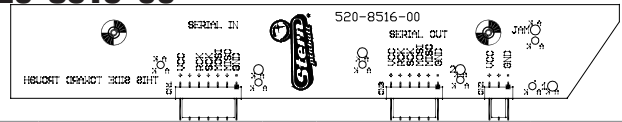

# 4.19 POWER DISTRIBUTION BOARD

520-1092-00

ID	Type	Pin	Description	Wire Color
CN1	.156 in 7-Pin Housing Plug: 045-5259-07 Pin: 055-5331-00 Key: 060-5013-00	1	+48 VDC IN	GRY
		2	+48 VDC IN	GRY
		3	+48 VDC IN	GRY
		4	NC	KEY
		5	Ground	BLK
		6	Ground	BLK
		7	Ground	BLK
CN2	.093 in 3-Pos Plug Plug: 045-5003-03 Pin: 055-5013-09	1	Line In (100-240 VAC)	BLK
		2	Neutral	WHT
		3	Earth Ground	GRN
CN3	0.084 in 4-Pos Plug Plug: 045-5200-04 Pin: 055-5033-08	1	+48 VDC to CPU Node	GRY
		2	Door Interlock Switch Status	GRY RED
		3	Line Voltage Status	VIO
		4	Ground	BLK
CN4	0.084 in 6-Pos Plug Plug: 045-5200-06 Pin: 055-5033-08	1	Door Interlock Switch +48V	WHT GRY
		2	Door Interlock Switch +48V	-
		3	Switched 48V Out (to Node 1)	GRY YEL
		4	Door Interlock Return Ground	BLK WHT
		5	Smart LED Ground	BLK
		6	Ground (to Node 1)	BLK
CN5	0.084 in 12-Pos Plug Plug: 045-5200-12 Pin: 055-5033-08	1	Switched 48V Node Power	GRY
		2	Switched 48V Node Power	GRY
		3	Switched 48V Node Power	GRY
		4	Switched 48V Node Power	-
		5	Switched 48V Node Power	-
		6	Switched 48V Node Power	-
		7	Node Ground	-
		8	Node Ground	-
		9	Node Ground	-
		10	Node Ground	BLK
		11	Node Ground	BLK
		12	Node Ground	BLK
CN6	.156 in 3-Pos Plug: 045-5259-03 Pin: 055-5331-00 (18awg)	1	Ground	-
		2	Ground	-
		3	+12VDC	-
CN7	.084 2-Pos Plug: 045-5200-02 Pin: 055-5033-08	1	+48 VDC to Topper Node	-
		2	Ground	-
CN9	.100 in 4-Pos	1	Start	GRY
		2	Action	TAN-WHT
		3	Ground	BLK-BRN
		4	Ground	BLK-BRN

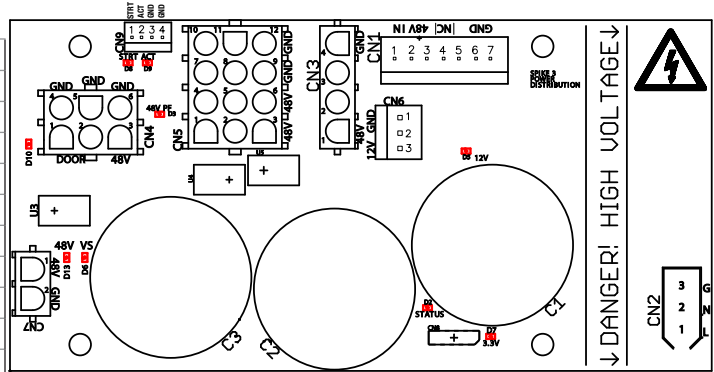

## STATUS LEDS

LED ID	Name	Color	Description
D13	48V	Red	48V from the main power supply
D6	VS	Red	Power to the bulk caps, indicates if the caps are charged
D3	48V PF	Red	Power to playfield/cabinet node
D5	12V	Red	12V power supply (for topper), shuts off when DOOR is open
D7	3.3V	Red	3.3V logic supply
D10	DOOR	Red	Cabinet door switch is closed
D8	STRT	Red	Start switch is closed
D9	ACT	Red	Action switch is closed
D2	STATUS	Red	MCU status
			Boot Mode - fast blink (4Hz), 75% duty cycle
			Runtime Mode - slow blink (1Hz), 75% duty cycle
			Blink several times, long pause - error code(s)

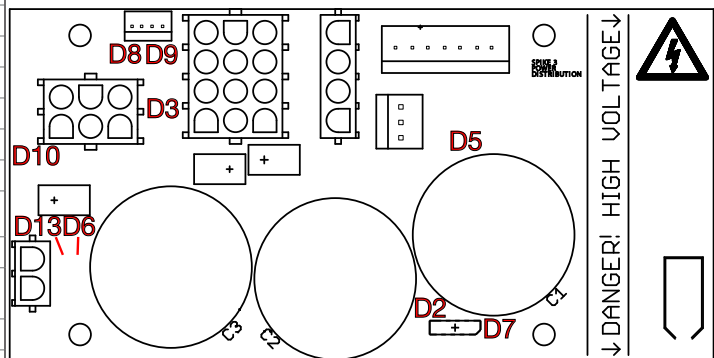

## 4.20 POWER SUPPLY 48V/600W 011-5011-00 (DELTA)

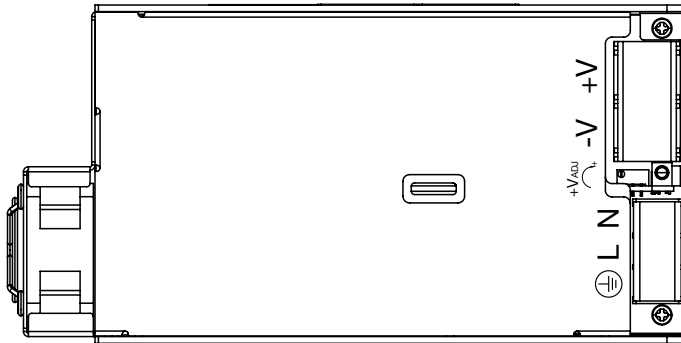

ID	Type	Pin	Description	Wire Color
CN1	Screw Terminal	+V	+48 V System Power	GRY
		-V	DC Ground	BLK
CN2	Potentiometer	+V ADJ	V Adjustment	N/A
CN3	Screw Terminal	N	AC Neutral In	WHT
		L	AC Line In	BLK
		⊕	Earth Ground In	GRN

## 4.21 POWER SUPPLY 48V/600W 011-5004-00 (MEANWELL)

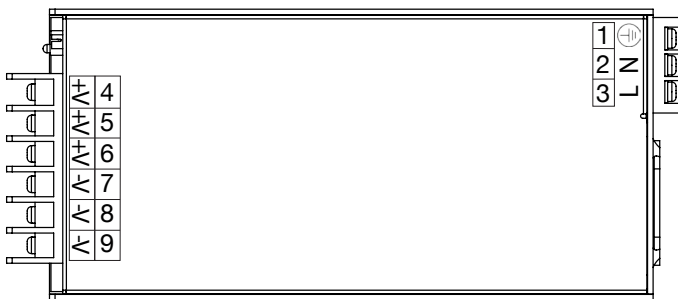

ID	Type	Pin	Description	Wire Color
CN1	Screw Terminal	1	Earth Ground In	GRN
		2	AC Neutral In	WHT
		3	AC Line In	BLK
CN2	Screw Terminal	4	+48 V System Power	GRY
		5	+48 V System Power	GRY
		6	+48 V System Power	GRY
		7	DC Ground	BLK
		8	DC Ground	BLK
		9	DC Ground	BLK

## 4.22 POWER PLUG WIRING

### CAUTION

**TO MAINTAIN SAFETY, GROUND WIRE FROM LINE FILTER IS TO BE MOUNTED FIRST ON GROUNDING STUD AND SECURED WITH NUT. ALL OTHER GROUNDS MAY THEN BE ATTACHED TO GROUNDING STUD.**

**REPLACE ALL FUSES WITH CORRECT CURRENT RATINGS!**

### NORTH AMERICA / INTERNATIONAL

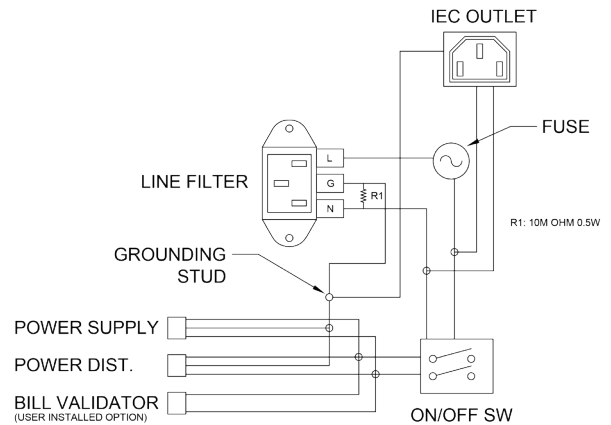

### LINE CORDS

Part Number	Description
034-6012-00	Line Cord, 3m, 5-15P USA
034-6012-01	Line Cord, 3m, CEE77P EUROPE
034-6012-02	Line Cord, 3m, BS1363P United Kingdom
034-6012-03	Line Cord, 3m, AS-NZS4417P Australia
034-6012-04	Line Cord, 3m, CEI23-16P Italy
034-6012-05	Line Cord, 3m, SEV1011P Switzerland
034-6012-06	Line Cord, 3m, JIS8303P Japan
034-6012-07	Line Cord, 3m, SI32P Israel
034-6012-08	Line Cord, 3m, BS546P S Africa, India
034-6012-09	Line Cord, 3m, IS6538P S. India

### LINE FUSES

Line Voltage (Region)	Fuse Current	Type	Part Number
120/250V (North America / International)	8 A	Slow Blow 5 x 20mm	200-5003-08



# 5. PARTS REFERENCE

## 5.1 PLAYFIELD RUBBER PARTS

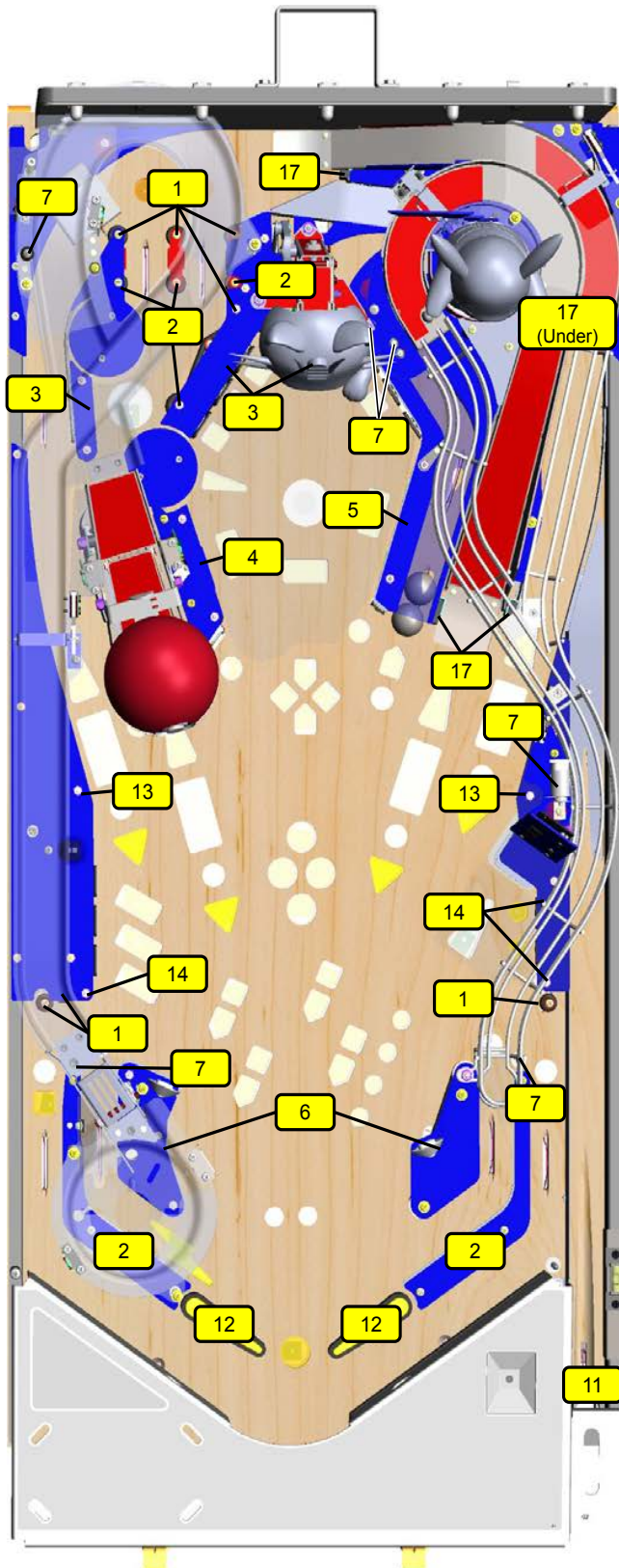

Figure 5.1.1. Rubber o-ring part locations

### RUBBER O-RINGS

ID	Qty	Size (ID)	Size (OD)	Durometer	Color	Part Number
1	7	3/16"		50	Black	545-5348-01
2	6	5/16"		50	Black	545-5348-02
3	4	1 - 1/4"		50	Black	545-5348-06
4	1	1 - 1/2"		50	Black	545-5348-07
5	1	1 - 3/4"		50	Black	545-5348-21
6	2	2 - 1/2"		50	Black	545-5348-09
7	6		7/16"	50	Black	545-5348-17

Figure 5.1.2. Rubber o-ring part numbers and usage. ID: Inner Diameter, OD: Outer Diameter, Durometer: Higher number is firmer, less bounce, and more durable.

ID	Qty	Description	Color	Part Number
11	1	Plunger Tip	Black	545-5276-00
12	2	Flipper Rubber	Black	545-5277-00
13	2	Post Sleeve	Red	545-9994-02
14	3	Post Sleeve	Black	545-5308-00
15	4	Bumper Pad (Sub assemblies)	Black	545-5105-00
16	2	Bumper Pad (Flippers)	Black	545-5428-00
17	4	Bumper Pad (Ball Guide)	Black	626-5057-01

Figure 5.1.3. Other rubber part numbers and usage

### 5.2 RUBBER SIZE CHART

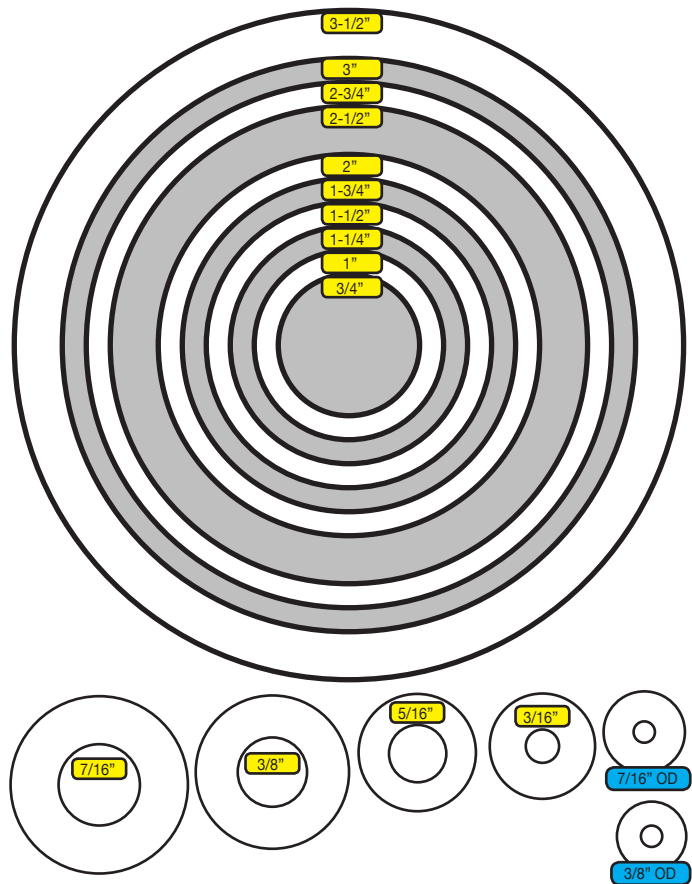
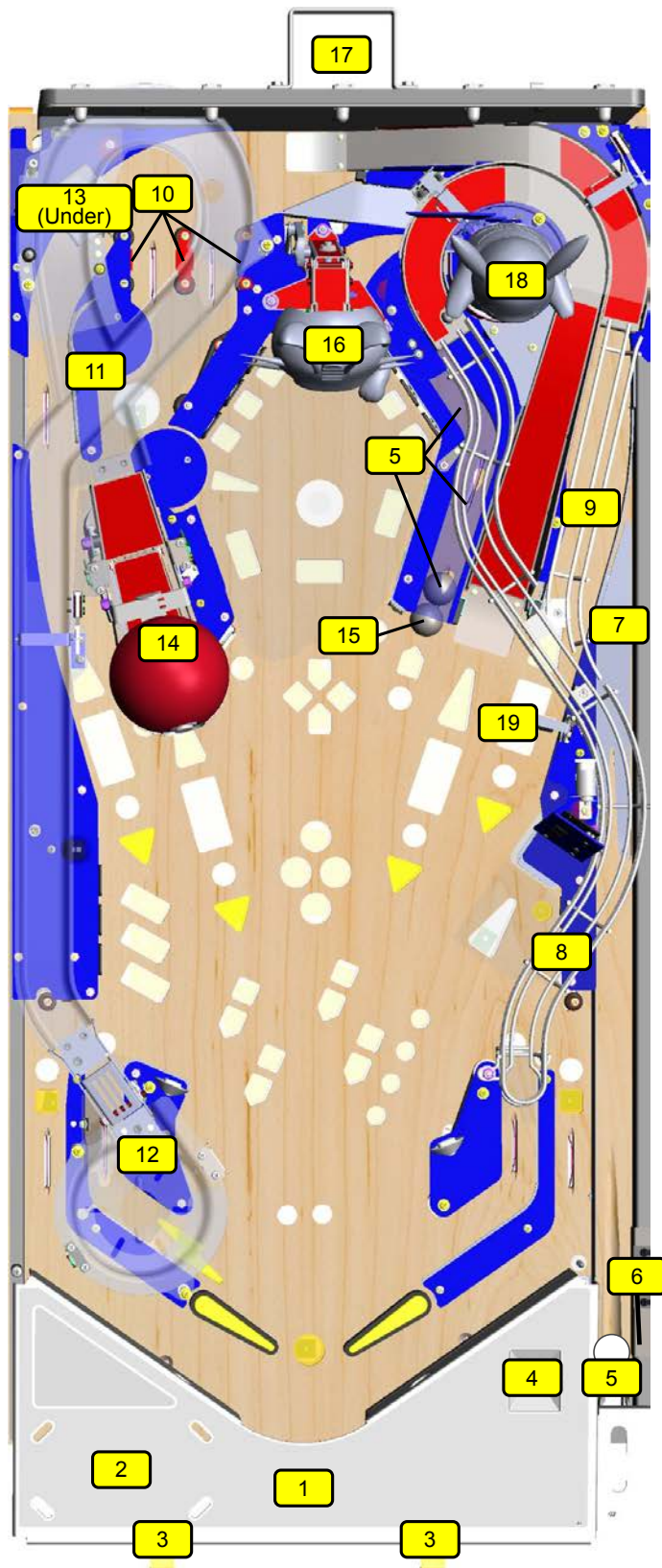

Figure 5.2.1. Rubber ring inner diameter sizing tool. Hold ring up to chart and read largest size on inside of ring. Dimensions are Inner Diameter (ID) unless otherwise noted as Outer Diameter (OD).

## 5.3 PLAYFIELD ASSEMBLIES, TOP



ID	Part Number	Description	Qty
1	500-2505-XX	Bottom Arch Assembly	1
2	755-51AJ-XX	Instructions Card	1
3	535-8385-00	Welded Hanger Bracket	2
4	524-1001-00	QR Reader	1
5	260-5000-00	Pinballs	9
6	500-6815-00	Bubble Level Assembly	1
7	535-4187-13	Shooter Lane Ramp (Ball Guide -13)	1
8	515-1094-00	Right Wire Ramp, Main	1
9	515-1094-01	Right Wire Ramp, Side	1
-	237-5853-00P	Screw, 6-32 x 1/4" (attaches right wire ramps together)	1
10	550-5061-02	Top Lane Mini Hood - Red	3
11	500-1217-00	Jump Ramp Assembly	1
-	237-5871-00P	Screw, 6-32 x 3/8" (for Jump Ramp and Bowl)	6
12	500-1219-00	Bonus Bowl Assembly	1
-	270-5001-00	Retaining E-Ring, 3/16" Shaft OD (to attach to Bowl Diverter Link)	1
13	511-5033-00	Elec Gate, Left Side Mounting	1
14	511-7965-00	Poké Ball Ramp Assembly	1
15	515-1935-00	Newton Ball	1
16	500-9962-00	Meowth Top Side Assembly	1
17	535-2288-00	Backpanel Handle	1
18	500-1216-00	Pikachu Ramp Assembly	1
19	511-5715-00	Reflective Opto Spinner, Ball Guide Mount	1

Figure 5.3.1. Major playfield assemblies, Top locations.

## 5.4 PLAYFIELD ASSEMBLIES, BOTTOM

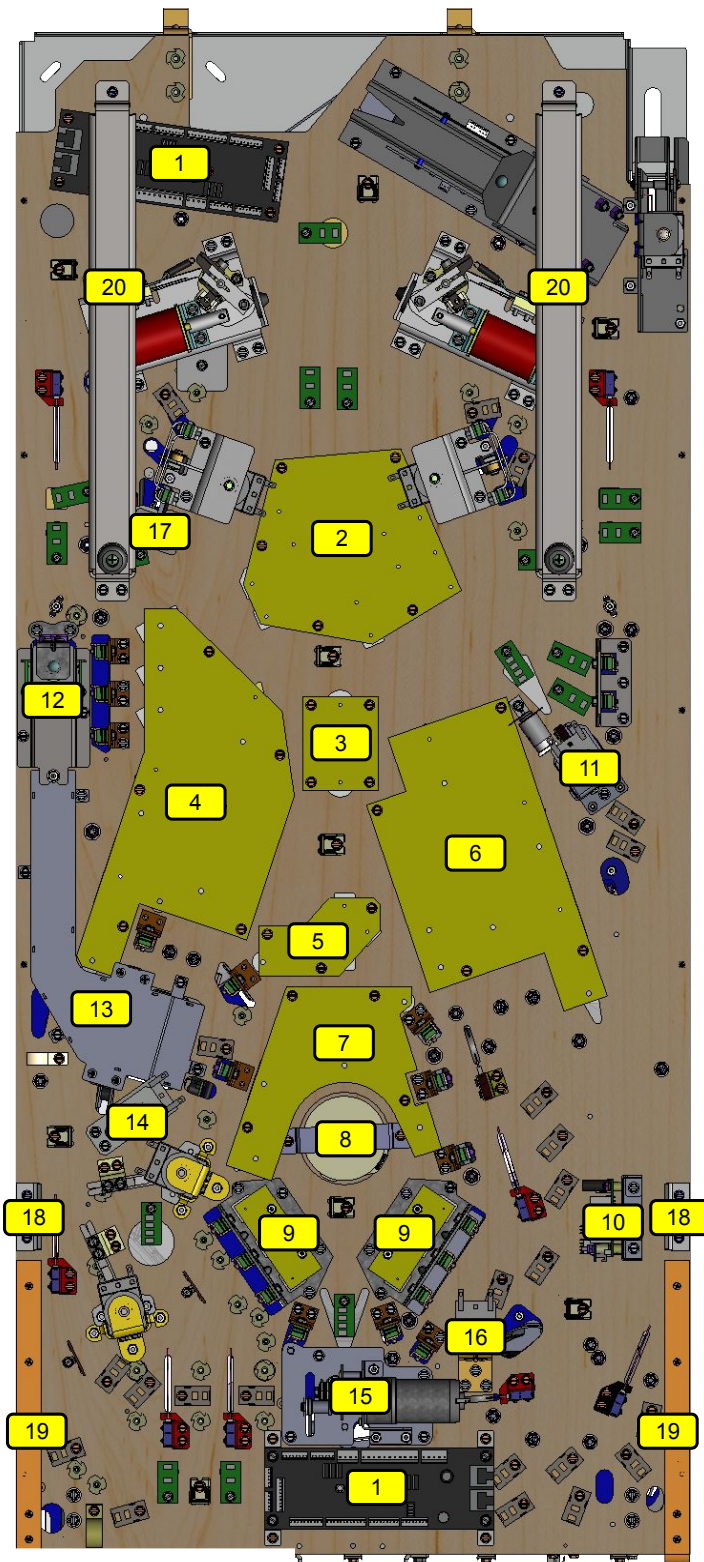

ID	Part Number	Description	Qty
1	520-1070-00 520-1057-00	Core Node Driver Board (8, 9)	2
2	520-7474-00	LED Serial Board - 12W BC (8b)	1
3	520-5801-00	LED Serial Board - 4W MC (8b1)	1
4	520-9875-00	LED Serial Board - 6R 4W ML (8c)	1
5	520-9886-00	LED Serial Board - 1R 4W ML (8c1)	1
6	520-9874-00	LED Serial Board - 6R 4W MR (9b)	1
7	520-9880-00	LED Serial Board - 5R TC (9a)	1
8	500-7425-00	Magnet Assembly	1
9	520-9885-00	LED Serial Board - 3R TC (9b1, 9b2)	2
10	520-5370-72	SPI Node Board (Node 10)	1
-	520-8685-00	Multi-Servo Interface SPI Board 10A (attached to Node 10)	1
11	500-1050-01	Eject VUK (under Town Billboard)	1
12	500-3655-00	Subway VUK Assembly (attaches to Poké Ball Ramp Subway with nut & washer)	1
-	242-5001-00	#6 Washer	1
-	240-5005-00	6-32 Nylon Stop Nut	1
13	511-4904-00	Poké Ball Ramp Subway	1
14	500-9962-01	Poké Ball Ramp Coil Assembly (connects to ramp plunger: spring>washer>e-ring)	1
-	266-5020-00	Conical Compression Spring	1
-	242-50081-00	Washer - Nylon .75 OD x .44 ID	1
-	270-5005-00	Retaining E-Ring, 7/16" Shaft OD	1
15	500-9962-02	Meowth Motor Assembly (attaches to Meowth Top Assembly with washer and e-ring)	1
-	242-5072-01	Nylon Washer, .252 ID x .472 OD	1
-	270-5002-00	Retaining E-Ring, 1/4" Shaft OD	1
16	500-3661-00	Up Post Assembly, Long (Pikachu Ramp)	1
17	500-3656-00	Bowl Diverter Coil Assembly	1
18	500-5329-03	Pivot Bracket Assembly	2
19	535-5988-01	Edge Slide Bracket	2
20	511-7621-00	Support Rail Assembly	2

Figure 5.4.1. Major playfield assemblies, Bottom locations.

## 5.5 BACKBOX PARTS

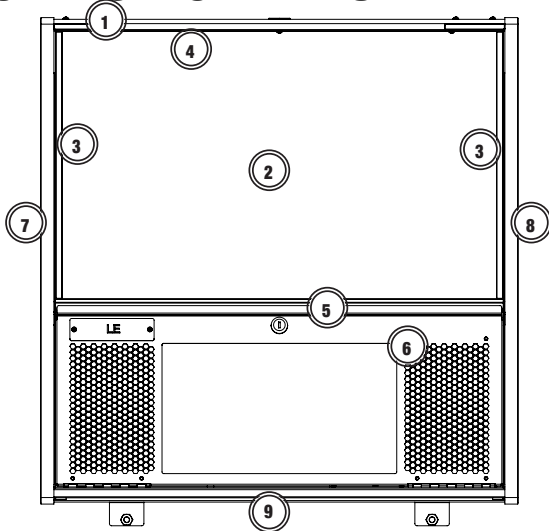

Figure 5.4.2. Backbox external assemblies and components

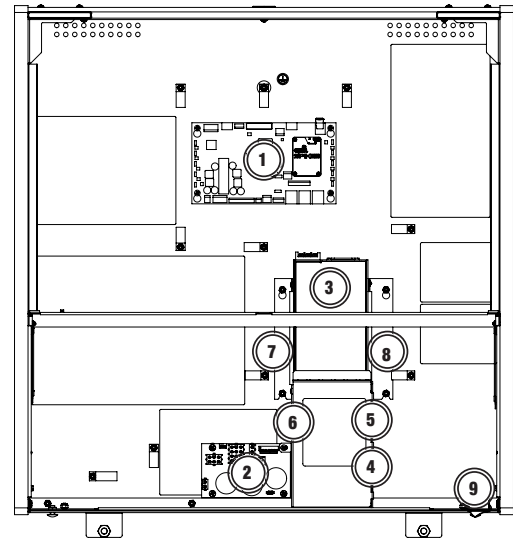

Figure 5.4.3. Backbox internal assemblies and components

### EXTERNAL

ID	Part Number	Description	Qty
1	545-9910-03	Backbox Bumper	2
2	830-8426-AJ	Mirror Backglass [LE]	1
	660-5052-00	Backglass	1
	830-8427-AH	Translite Art [Premium]	1
3	545-5018-17	Plastic Extrusion 15-.450"	2
4	545-5018-15	Glass Channel 26"	1
5	545-6313-01	Glass Lift Channel 26"	1
6	500-9404-AJ	LCD Speaker Panel Assembly [LE]	1
	500-9404-01	LCD Speaker Panel Assembly [Premium]	1
7	820-81AJ-01	Left Backbox Decal [LE]	1
	820-81AH-01	Left Backbox Decal [Premium]	1
8	820-81AJ-02	Right Backbox Decal [LE]	1
	820-81AH-02	Right Backbox Decal [Premium]	1
9	515-8868-00	Backbox Bottom Bracket	1

### INTERNAL

ID	Part Number	Description	Qty
1	524-1002-00	CPU Node Board	1
2	520-1092-00	Power Distribution Board	1
3	011-5004-00	Power Supply 48V/600W (Meanwell)	1
	011-5011-00	Power Supply 48V/600W (Delta)	1
4	205-5004-00	Fuse Holder - Screw In	1
	200-5003-08	8A SB Fuse	1
5	515-9769-00	Utility Outlet (USA)	1
6	535-1130-00	Cover AC, 600W (Meanwell)	1
	535-3050-00	Cover AC, 600W (Delta)	1
7	535-0879-00	P. S. Bracket, 600W Left (Meanwell)	1
*	535-0094-00	P. S. Bracket, 600W (Delta only uses 1)	1
8	535-1161-00	P. S. Bracket, 600W Right (Meanwell)	1
9	180-5001-03	Power Switch	1

## 5.6 LOCKDOWN BAR ASSEMBLY W/ CENTER BUTTON

500-2440-79 [LE] & 500-2440-99 [PREMIUM]

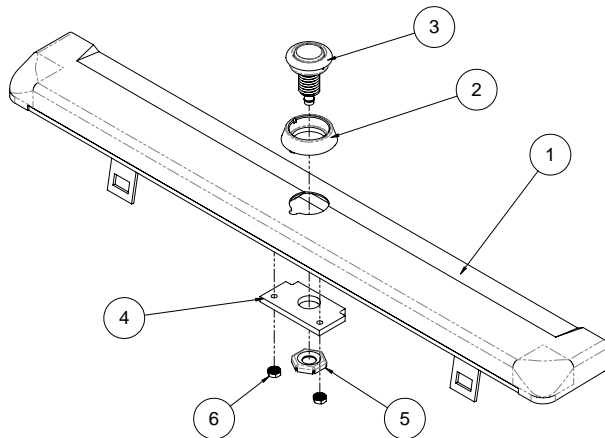

ID	Part Number	Description	Qty
1	500-2441-79	FRONT MOLD ASSEMBLY - CENTER BUTTON - PLAYGROUND PURPLE [LE]	1
	500-2441-99	FRONT MOLD ASSEMBLY - CENTER BUTTON [PREMIUM]	1
2	545-7292-10	SPACER, CENTER BUTTON	1
3	515-7791-00	CENTER BUTTON ASSEMBLY	1
4	545-7291-00	TOP BUTTON BAR	1
5	240-5003-01	PAL NUT	1
6	240-5104-00	8-32 KEPS NUT	2

## 5.7 SPEAKER PANEL ASSEMBLY

500-9404-01

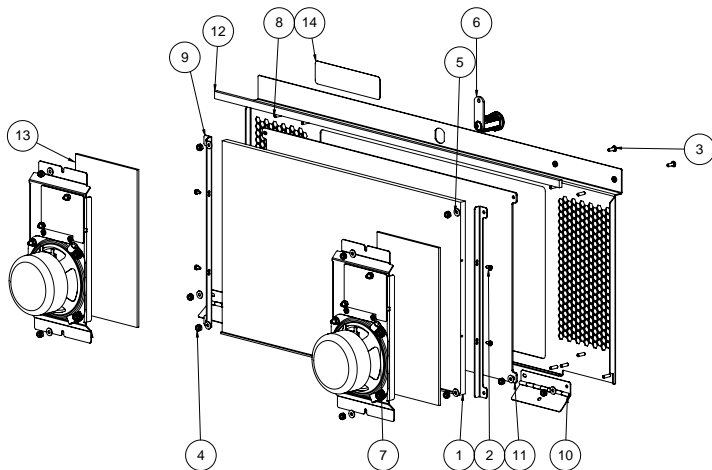

ID	Part Number	Description	Qty
1	116-0036-40	18.5IN LCD	1
-	037-6034-10	LITEMAX LCD BACK LIGHT CABLE	1
-	037-8062-30	LVDS CABLE 18.5 FHD	1
2	237-6188-01P	SCREW, M3x0.5 X 6MM PPH SEMS ZINC, PATCH	4
3	237-6307-06	SCREW, 6-32 X 3/8" PAN TORX SS	2
4	240-5005-00	6-32 NYLON STOP NUT	12
5	242-5001-00	#6 WASHER	12
6	355-5175-00	CAM LOCK 1-3/16" BODY	1
7	511-3645-01	ASM SPEAKER BRKT MOUNT, PREM/PRO SPIKE 3	2
-	036-5600-46	SPEAKER PANEL CABLE W/ CONNECTORS	1
8	515-8870-99	SPEAKER PANEL 18.5IN LCD	1
9	515-8871-00	MOUNTING BRACKET 18.5IN LCD	2
10	515-8872-00	HINGE SPEAKER PANEL 18.5IN LCD	2
11	545-9995-00	LCD LENSE, 18.5IN SCREEN	1
12	626-5001-00	FOAM TAPE - 3/8 X 3/16 THK (BLACK)	1
13	626-5139-00	SPEAKER FOAM - LCD PANEL	2
14	820-6961-01	DECAL SPEAKER PANEL CONNECTED - SPIKE 3	1

## 5.8 SPEAKER BRACKET MOUNT ASSEMBLY

511-3645-00

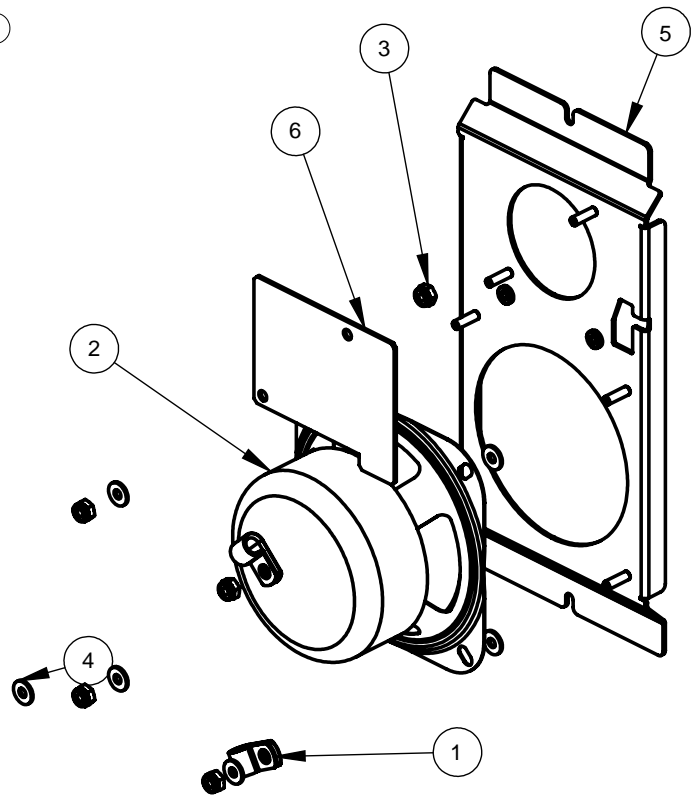

ID	Part Number	Description	Qty
1	040-5000-23	WIRE CLAMP, 1/4" CLOSED TAB	2
2	031-5026-00	SPKR 4 X 4 in 8 OHM MID RANGE	1
3	240-5005-00	6-32 NYLON STOP NUT	8
4	242-5001-00	#6 WASHER	8
5	515-8873-00	BRKT SPEAKER MOUNT SPIKE 3	1
6	535-3367-00	BLANKING PLATE	1

## 5.9 SPEAKER PANEL ASSEMBLY [LE] 500-9404-AJ

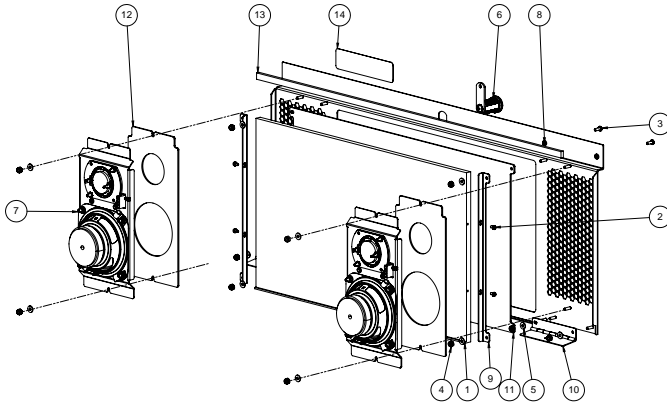

ID	Part Number	Description	Qty
1	116-0036-40	LITEMAX 18.5IN LCD	1
-	037-6034-10	LITEMAX LCD BACK LIGHT CABLE	1
-	037-8062-30	LVDS CABLE 18.5 FHD	1
2	237-6188-01P	SCREW, M3x0.5 X 6MM PPH SEMS ZINC, PATCH	4
3	237-6307-06	SCREW, 6-32 X 3/8" PAN TORX SS	2
4	240-5005-00	6-32 NYLON STOP NUT	12
5	242-5001-00	#6 WASHER	12
6	355-5175-00	CAM LOCK 1-3/16" BODY	1
7	511-3645-02	ASM SPEAKER BRKT MOUNT, LE SPIKE 3	2
-	036-5600-46	SPEAKER PANEL CABLE W/ CONNECTORS	1
-	036-5600-82	RGB SPEAKER CABLE	1
8	515-8870-99	SPEAKER PANEL 18.5IN LCD	1
9	515-8871-00	MOUNTING BRACKET 18.5IN LCD	2
10	515-8872-00	HINGE SPEAKER PANEL 18.5IN LCD	2
11	545-9995-00	LCD LENSE, 18.5IN SCREEN	1
12	546-5040-01	LIT SPEAKER LENS - POKÉ BALL	2
13	626-5001-00	FOAM TAPE - 3/8 X 3/16 THK (BLACK)	1
14	820-6961-01	DECAL SPEAKER PANEL CONNECTED - SPIKE 3	1

## 5.10 SPEAKER BRACKET MOUNT ASSEMBLY [LE] 511-3645-02

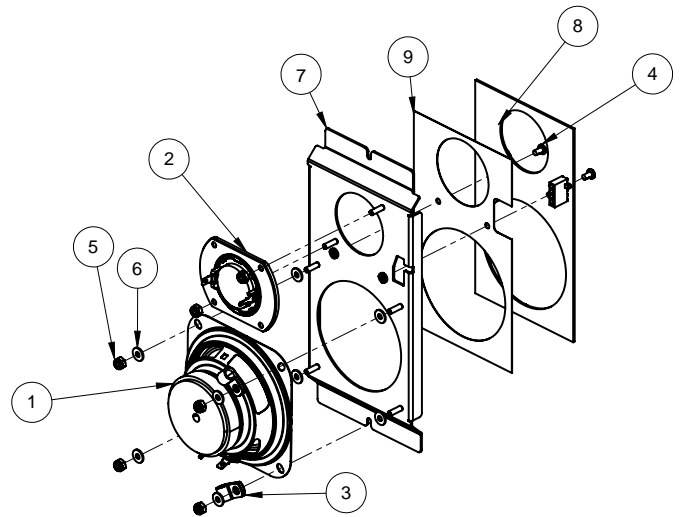

ID	Part Number	Description	Qty
1	031-5026-00	SPK 4" MID RANGE 8 OHM GEN 3 CAB	1
2	031-5028-00	SPK TWEETER 8 OHM GEN 3 CAB	1
3	040-5000-23	WIRE CLAMP, 1/4" CLOSED TAB	2
4	237-5500-01P	SCREW, 6-32 X 1/4" PPH MS BLACK, PATCH	2
5	240-5005-00	6-32 NYLON STOP NUT	6
6	242-5001-00	#6 WASHER	8
7	515-8873-00	BRKT SPEAKER MOUNT SPIKE 3	1
8	520-9865-00	PCA SPKR LIGHTING SPIKE 3	1
9	523-0051-00	FISH PAPER SPIKE 3 EXPRESSION LIGHTS	1

## 5.11 CABINET PARTS

Coming Soon.....



## 5.12 BALL SHOOTER ASSEMBLY

500-2604-07

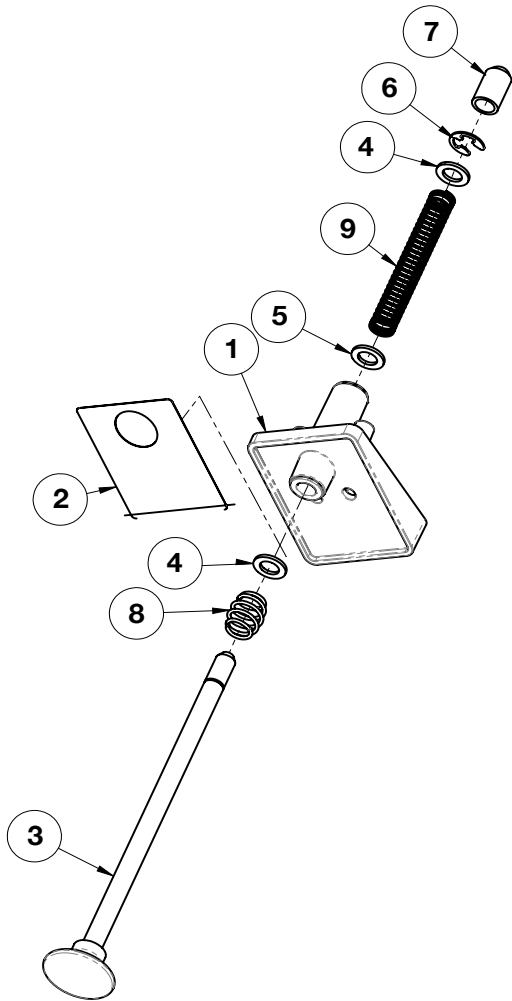

ID	Part Number	Description	Qty
1	515-2436-01	HOUSING ASSEMBLY	1
2	820-1408-00	DECAL - SHOOTER HOUSING SPI	1
3	515-6557-00	ROD ASSEMBLY	1
4	242-5014-00	WASHER 3/8 ID X 5/8 OD X 1/16"	2
5	242-5637-00	NYLON WASHER 3/8 ID X 5/8 OD X 1/16"	1
6	270-5012-00	RETAINING RING, 3/8"	1
7	545-5276-00	RUBBER TIP	1
8	266-5010-00	COMPRESSED SPRING (SHORT)	1
9	266-5001-04	COMPRESSED SPRING (LONG) - GREEN	1

## 5.13 AUTO LAUNCH ASSEMBLY

500-9818-02

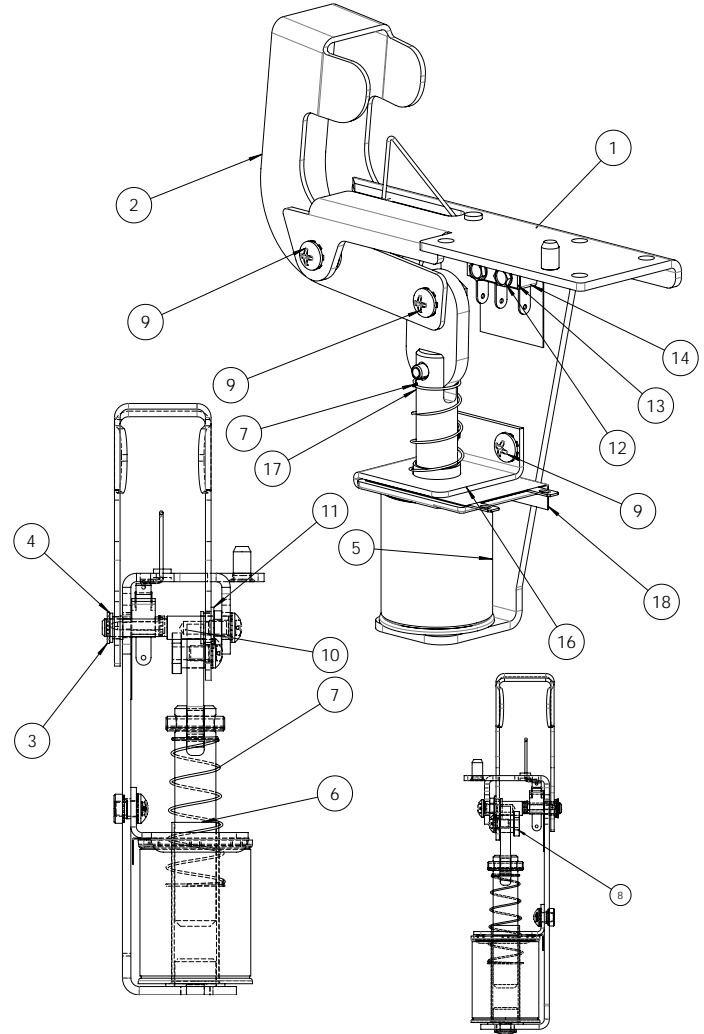

ID	Part Number	Description	Qty
1	515-9689-01	MAIN BRKT: AUTO-PLUNGER	1
2	535-0728-00	KICKER ARM, AUTO-PLUNGER	1
3	270-5001-00	RETAINING E-RING, 3/16" SHAFT OD	1
4	545-5352-00	NYLINER, 3/16" SHAFT	1
5	090-5001-ND	COIL - 23-800, NO DIODE	1
6	545-5411-00	COIL SLEEVE	1
7	266-5020-00	COMPRESSION SPRING-CONICAL	1
8	530-7834-00	PIN: KICKER ARM, AUTO-PLUNGER	1
9	232-5300-00	SCREW, 8-32 X 1/4" PPH SEMS	4
10	530-7835-00	PIVOT, AUTO-PLUNGER	1
11	545-5423-00	NYLINER, 1/4" SHAFT, 4L1-FF	1
12	237-5937-02	SCREW, 2-56 X 1/2" HWH MS	2
13	535-6539-00	SWITCH BODY PROTECT PLATE	1
14	180-5157-01	SHOOTER SWITCH - SHORT ARM	1
15	545-6268-00	FISCHE PAPER	1
16	535-0762-00	COIL BRACKET-AUTOPLUNGER	1
17	515-6304-03	PLUNGER / LINK ASSEMBLY	1
18	545-0762-00	FISCHE PAPER: AUTO-LAUNCHER	1

## 5.14 BALL TROUGH ASSEMBLY

500-9820-01

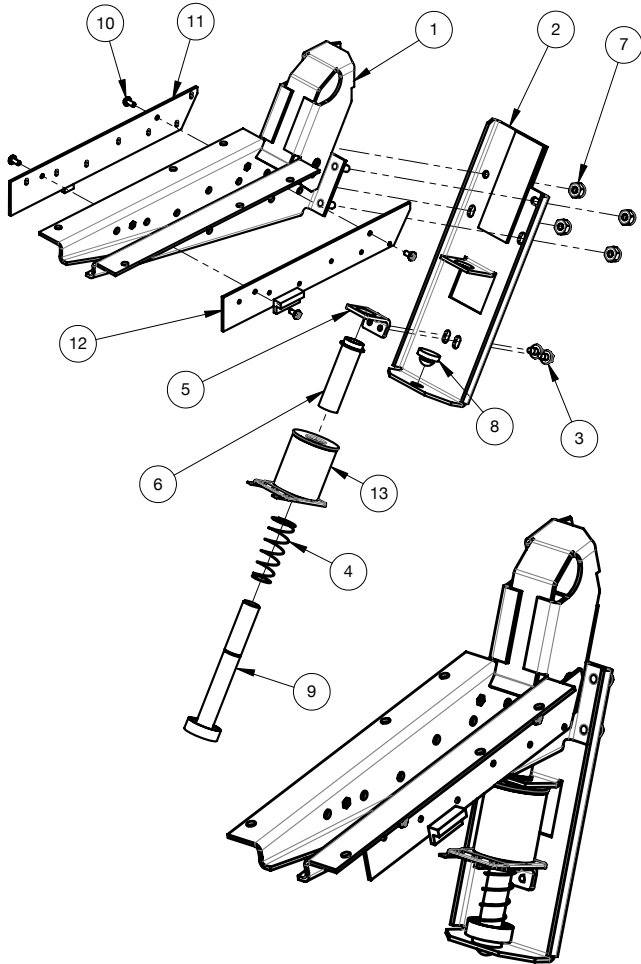

ID	Part Number	Description	Qty
1	515-7811-00	MAIN BRKT. BALL TROUGH	1
2	515-7812-00	COIL BRACKET, BALL TROUGH	1
3	237-5975-04	SCREW, 8-32 X 1/4" HWH SWAGE SERR	2
4	266-5020-00	COMPRESSION SPRING-CONICAL	1
5	535-5203-03	COIL RETAINING BRACKET	1
6	545-5076-01	COIL SLEEVE	1
7	240-5102-00	8-32 NYLON LOCK NUT	4
8	545-5105-00	RUBBER BUMPER	1
9	515-7309-01	PLUNGER ASSEMBLY	1
10	237-5909-00	SCREW, 4-40 X 1/4" PPH SEMS	4
11	520-5344-00	TROUGH BOARD #1 - ILED TRANSMITTER	1
12	520-8516-00	TROUGH BOARD #2 - RECEIVER	1
13	090-5004-ND	COIL 27-1500 - NO DIODE	1
98*	605-5006-00	SHRINK TUBING 1/8"	.42 FT.
99*	036-5611-11-F5	CABLE TROUGH OPTOS	1

## 5.15 SLINGSHOT ASSEMBLY

500-9920-01

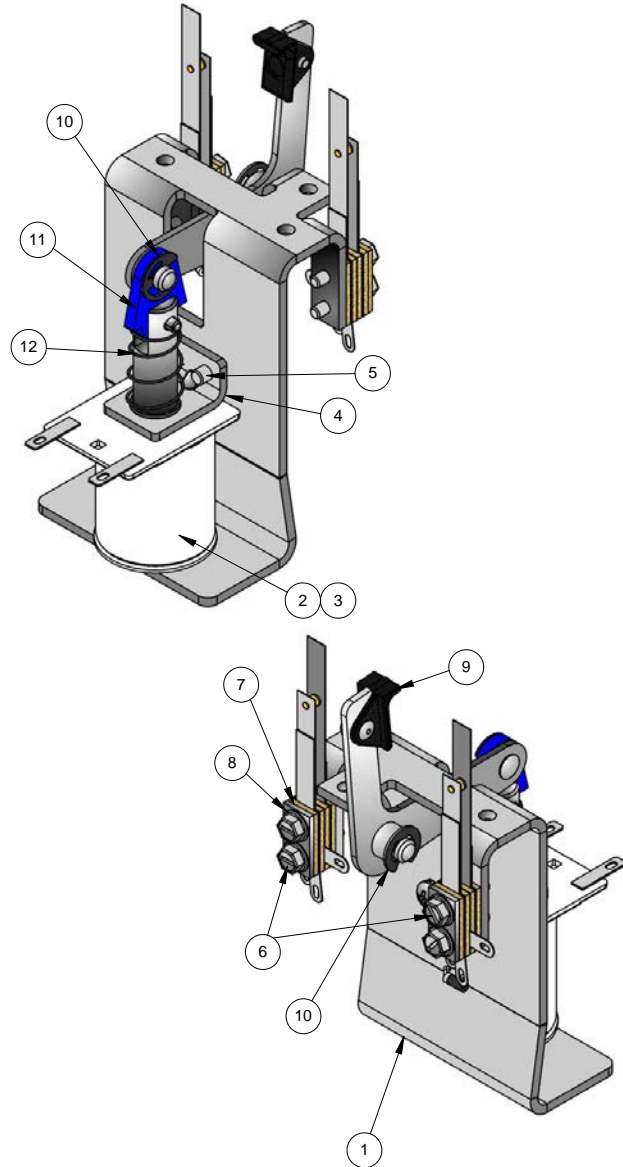

ID	Part Number	Description	Qty
1	515-5339-01	SLINGSHOT BRACKET ASSEMBLY	1
2	090-5044-ND	COIL 26-1200 - NO DIODE	1
3	545-5031-00	COIL SLEEVE	1
4	535-5203-03	COIL RETAINER BRACKET	1
5	232-5301-00	8-32 X 3/8 PPH MS EXT SEMS ZC	2
6	180-5231-00	SWITCH SLING SHOT 2 LUG CENTER	2
7	535-5045-00	SWITCH PLATE	2
8	237-5976-04	6-32 X 5/8 SLOT SER HWH SW	4
9	515-5340-01	ARM & TIP ASSEMBLY	1
10	270-5002-00	RETAINING RING - 1/4 DIA	2
11	515-5338-00	PLUNGER & LINK ASSEMBLY	1
12	266-5020-00	COMP SPRING CONICAL	1
13	036-5604-00	4" GENERIC JUMPER	2

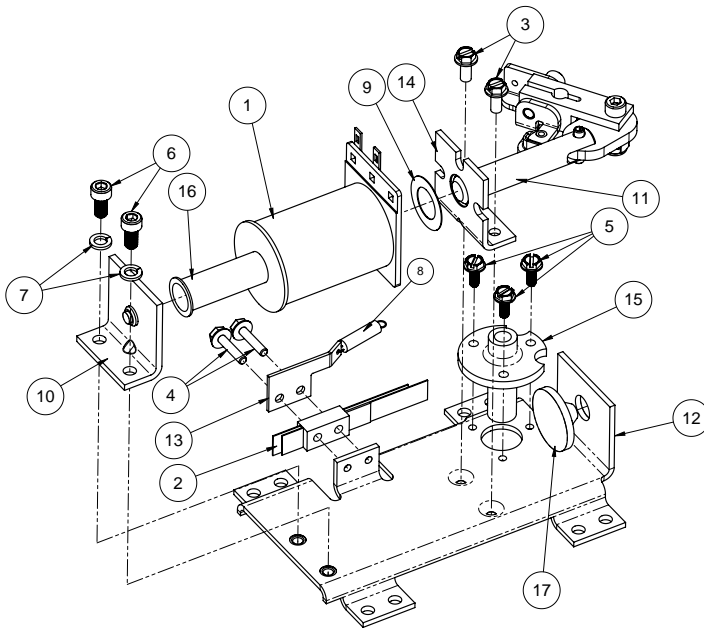
**5.16 FLIPPER ASSEMBLY, LEFT****500-6543-13-ND**

ID	Part Number	Description	Qty
1	090-5020-30-ND	FLIPPER COIL (23-900)	1
2	180-5149-00	SWITCH, END-OF-STROKE	1
3	237-5975-00	SCREW, 8-32 X 3/8" HWH SWAGE ZN	2
4	237-5976-04	SCREW, 6-32 X 5/8" HWH SWAGE	2
5	237-6388-00	SCREW, 6-32 X 3/8", SLOTTED HWH, TYPE F	3
6	237-6389-00	SCREW, 10-32 X 3/8", SHC	2
7	244-5003-00	#10 LOCK WASHER, SPLIT	2
8	265-5035-00	EXTENSION SPRING	1
9	269-5002-00	SPRING WASHER	1
10	515-6308-01	COIL STOP ASSEMBLY	1
11	515-7203-01	PLUNGER / CRANK ASSEMBLY	1
12	535-7275-01	FLIPPER BASE PLATE, LEFT	1
13	535-7354-01	SWITCH PLATE / SPRING RTN BRKT	1
14	535-7356-00	COIL BRACKET	1
15	545-5070-00	FLIPPER BUSHING	1
16	545-5388-00	COIL SLEEVE	1
17	545-5428-00	RUBBER BUMPER	1
18	515-5133-06-06	FLIPPER BAT AND SHAFT (YELLOW)	1
19	545-5277-00	FLIPPER RUBBER	1

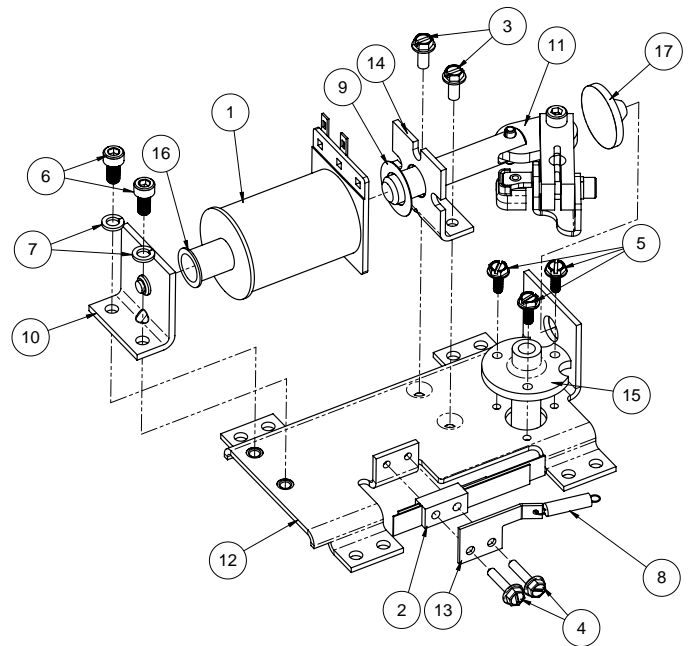
**5.17 FLIPPER ASSEMBLY, RIGHT****500-6543-03-ND**

ID	Part Number	Description	Qty
1	090-5020-30-ND	FLIPPER COIL (23-900)	1
2	180-5149-00	SWITCH, END-OF-STROKE	1
3	237-5975-00	SCREW, 8-32 X 3/8" HWH SWAGE ZN	2
4	237-5976-04	SCREW, 6-32 X 5/8" HWH SWAGE	2
5	237-6388-00	SCREW, 6-32 X 3/8", SLOTTED HWH, TYPE F	3
6	237-6389-00	SCREW, 10-32 X 3/8", SHC	2
7	244-5003-00	#10 LOCK WASHER, SPLIT	2
8	265-5035-00	EXTENSION SPRING	1
9	269-5002-00	SPRING WASHER	1
10	515-6308-01	COIL STOP ASSEMBLY	1
11	515-7203-00	PLUNGER / CRANK ASSEMBLY	1
12	535-7275-00	FLIPPER BASE PLATE, RIGHT	1
13	535-7354-00	SWITCH PLATE / SPRING RTN BRKT	1
14	535-7356-00	COIL BRACKET	1
15	545-5070-00	FLIPPER BUSHING	1
16	545-5388-00	COIL SLEEVE	1
17	545-5428-00	RUBBER BUMPER	1
18	515-5133-06-06	FLIPPER BAT AND SHAFT (YELLOW)	1
19	545-5277-00	FLIPPER RUBBER	1

# 5.18 POP BUMPER ASSEMBLY

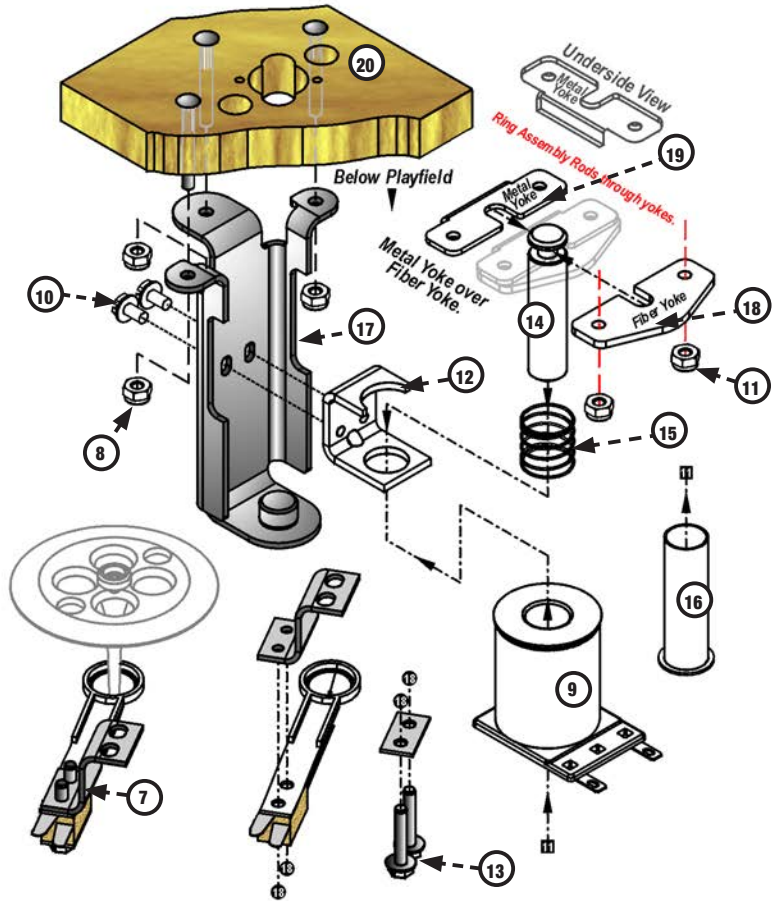
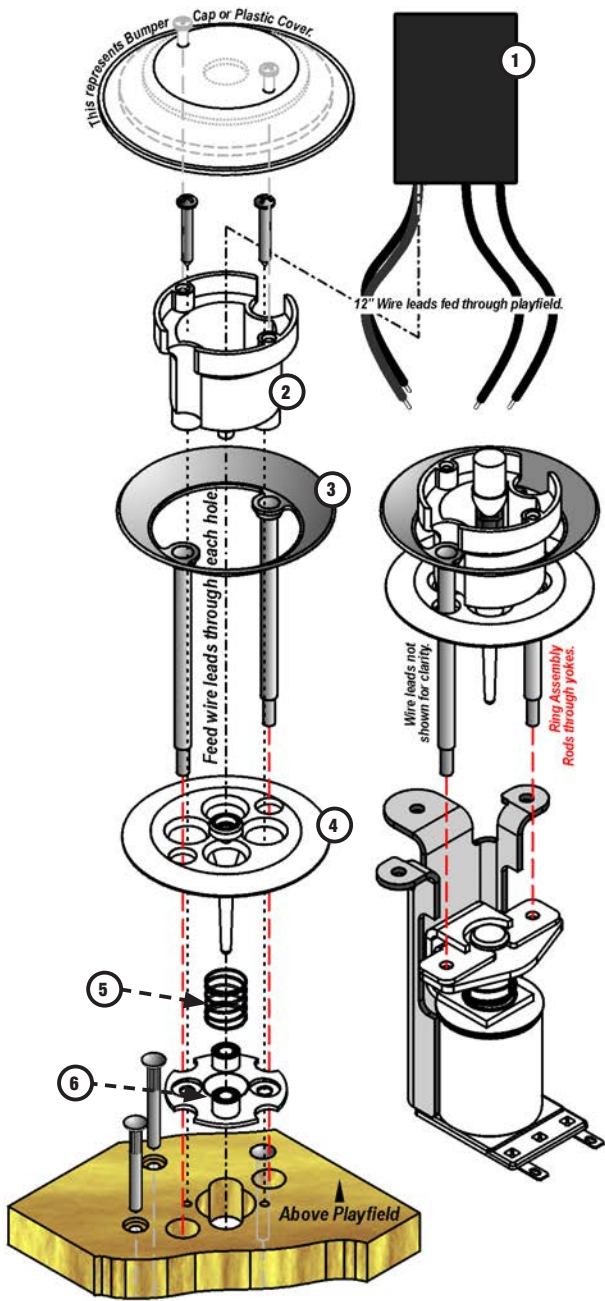

Part Number	Description	Qty
511-1981-01	BUMPER/RING TOP ASSY, W/ LED	2
515-6459-04-ND	BUMPER BOTTOM ASSY, NO DIODE	3

ID	Part Number	Description	Qty
7	500-9934-01	POP BUMPER SWITCH ASSY-2 - LUG-LEFT	1
8	240-5005-00	6-32 NYLON STOP NUT	3
9	090-5044-ND	COIL - 26-1200	1
10	237-5976-01	#6-32 X 1/4" SHWH SWAGE ZN	2
11	240-5005-00	#6-32 NYLON STOP NUT	2
12	535-7347-00	METAL YOKE STOP	1
13	234-5101-00	SCREW, 8 X 1/2 SLT	6
14	530-5348-00	PLUNGER, POP BUMPER	1
15	266-5047-00	COMPRESSION SPRING, POP BUMPER	1
16	545-5031-00	COIL SLEEVE	1
17	515-5939-00	COIL BRACKET POP BUMPER ASSY	1
18	545-5609-00	FIBER YOKE	1
19	535-7346-00	METAL YOKE	1
20	237-5957-00	#6-32 x 1-3/16" SPIRAL FIN SHANK SCREW	3

ID	Part Number	Description	Qty
1	511-7670-00	POP BUMPER RGB LED MODULE	1
2	545-5197-00	BUMPER BODY	1
3	515-5085-00	RING AND ROD ASSY	1
-	515-5085-04	RING AND ROD ASSY - TRIMMED	
4	545-5607-00	BUMPER SKIRT	1
5	266-5048-00	BUMPER SKIRT COMP SPRING	1
6	545-5195-00	BUMPER BASE	1

Left Pop Bumper has a trimmed ring, with the flat side facing to the left.

### 5.19 BOTTOM ARCH ASSEMBLY

500-2505-AJ [LE] & 500-2548-AH [PREMIUM]

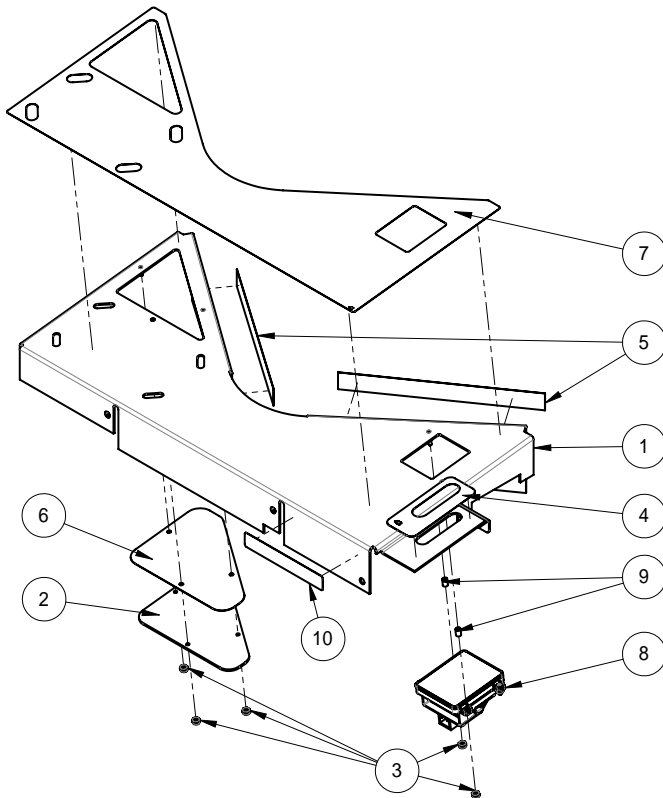

ID	Part Number	Description	Qty
1	510-7805-00	BOTTOM ARCH, STEEL W/ SPADE BOLT, QR READY	1
2	830-8502-AJ	LEFT SIDE ARCH PLASTIC [LE]	1
-	830-8502-AH	LEFT SIDE ARCH PLASTIC [Premium]	1
3	240-5303-00	4-40 NYLON LOCK NUT	5
4	820-97AJ-02	METAL ARCH DECAL SET -02	1
5	545-5212-04	MYLAR PROTECT STRIP 7-5/8"	2
6	545-9923-00	COVER, SIGNATURE PROTECTOR, METAL ARCH	1
7	820-97AJ-01	METAL ARCH DECAL SET -01	1
8	524-1001-00	QR SCANNER ASSEMBLY	1
9	254-5090-04	PLASTIC SPACER #4 SCREW, 3/16" OD - 9/32" LENGTH	2
10	820-5422-00	WARNING DECAL, BOTTOM ARCH, QR READER	1

### 5.20 JUMP RAMP ASSEMBLY

500-1217-00

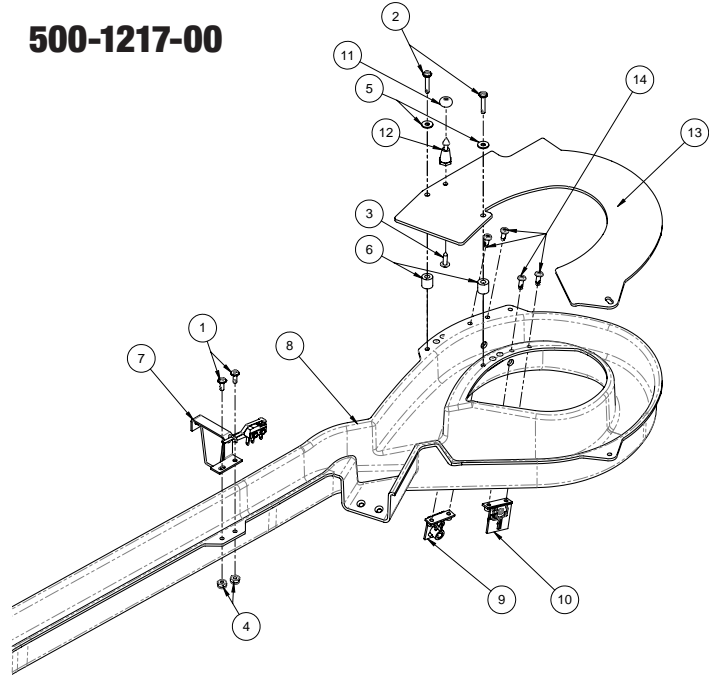

ID	Part Number	Description	Qty
1	232-5201-00P	SCREW, 6-32 X 3/8" PPH MS SEMS, PATCH	2
2	232-5204-00P	SCREW, 6-32 X 3/4" PPH SEMS, PATCH	2
3	237-5809-00	SCREW, #6 X 1/2" PTH A	1
4	240-5005-00	6-32 NYLON STOP NUT	2
5	242-5001-00	#6 WASHER	2
6	254-5000-12	NYLON SPACER - BLACK - 3/8 OD X .175 ID X 3/8"	2
7	500-9936-04	GATE ASSEMBLY	1
8	510-8024-00	RIVETED JUMP RAMP, PANTS	1
9	515-0215-00	LONG RANGE OPTO EMITTER ASSEMBLY	1
10	515-0215-01	LONG RANGE OPTO RECEIVER ASSEMBLY	1
11	545-5348-17	7/16 O.D. RUBBER RING - BLACK	1
12	550-5052-01	MINI POST - CLEAR	1
13	830-6982-01	PLASTIC 100, POKÉMON, -01	1
14	237-5880-00	SCREW, #6 X 3/8 PPH T-25	4

### 5.21 GATE ASSEMBLY (JUMP RAMP)

500-9936-04

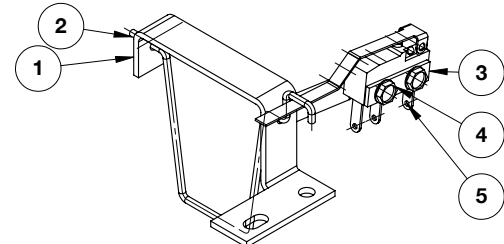

ID	Part Number	Description	Qty
1	535-7756-01	BRACKET - GATE	1
2	535-7755-02	WIRE FORM	1
3	535-6539-00	SWITCH BODY PROTECT PLATE	1
4	237-5937-02	SCREW, 2-56 X 1/2" HWH MS	2
5	180-5087-00	SWITCH - GATE	1



## 5.22 BONUS BOWL ASSEMBLY

500-1219-00

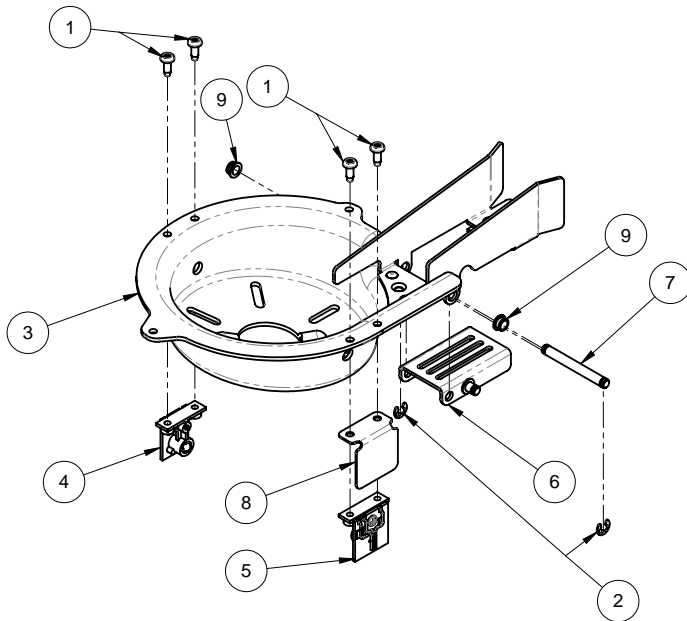

ID	Part Number	Description	Qty
1	237-5880-00	SCREW, #6 X 3/8 PPH T-25	4
2	270-5001-00	RETAINING E-RING, 3/16" SHAFT OD	2 (3)
3	510-8021-00	RIVETED BOWL DIVERTER, POKÉMON	1
4	515-0215-00	LONG RANGE OPTO EMITTER ASSEMBLY	1
5	515-0215-01	LONG RANGE OPTO RECEIVER ASSEMBLY	1
6	515-3040-00	TRAPDOOR, BOWL DIVERTER, POKÉMON	1
7	530-7812-18	PIVOT PIN-.188 DIA.	1
8	535-2431-00	PROTECTOR, OPTO	1
9	545-5352-00	NYLINER, 3/16" SHAFT	2

## 5.23 BOWL DIVERTER COIL ASSEMBLY

500-3656-00

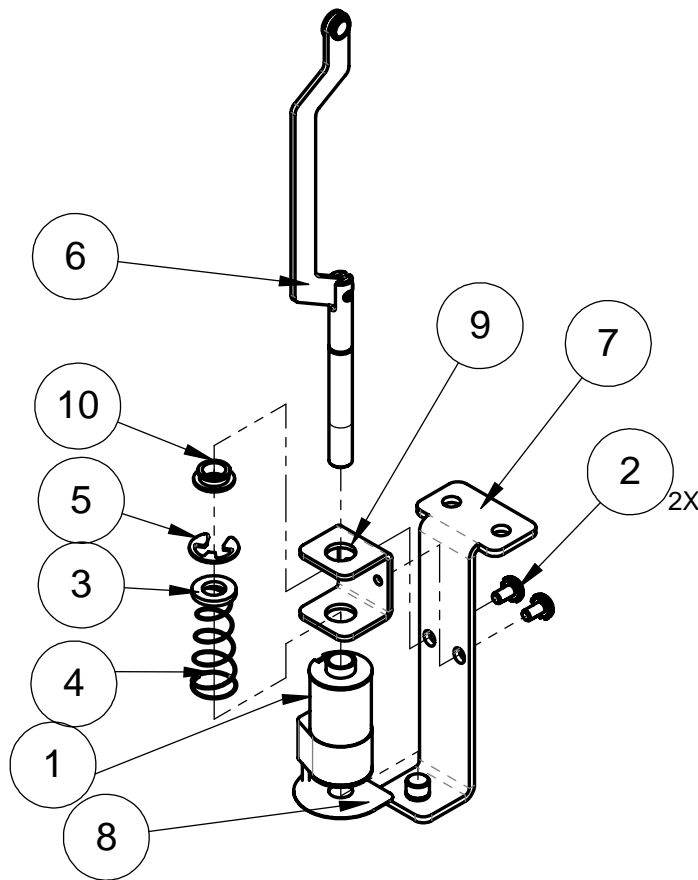

ID	Part Number	Description	Qty
1	090-5074-03	COIL, MINI, FLEX CABLE	1
2	232-5200-00P	SCREW, 6-32 X 1/4" PPH SEMS, PATCH	2
3	242-5072-01	NYLON WASHER .252 ID X .472 OD	1
4	266-5117-00	SPRING, JAW	1
5	270-5002-00	RETAINING RING - 1/4"	1
6	511-3673-00	PLUNGER ASSEMBLY, BOWL DIVERTER COIL	1
7	515-3266-00	ASSEMBLY, BACK STOP, BOWL DIVERTER COIL	1
8	523-0053-00	FISCHE PAPER, BOWL DIVERTER, POKÉMON	1
9	535-2922-00	PLUNGER SUPPORT, BOWL DIVERTER, POKÉMON	1
10	545-5423-00	NYLINER, 1/4" SHAFT, 4L1-FF	1

## 5.24 EJECT VUK ASSEMBLY

500-1050-01

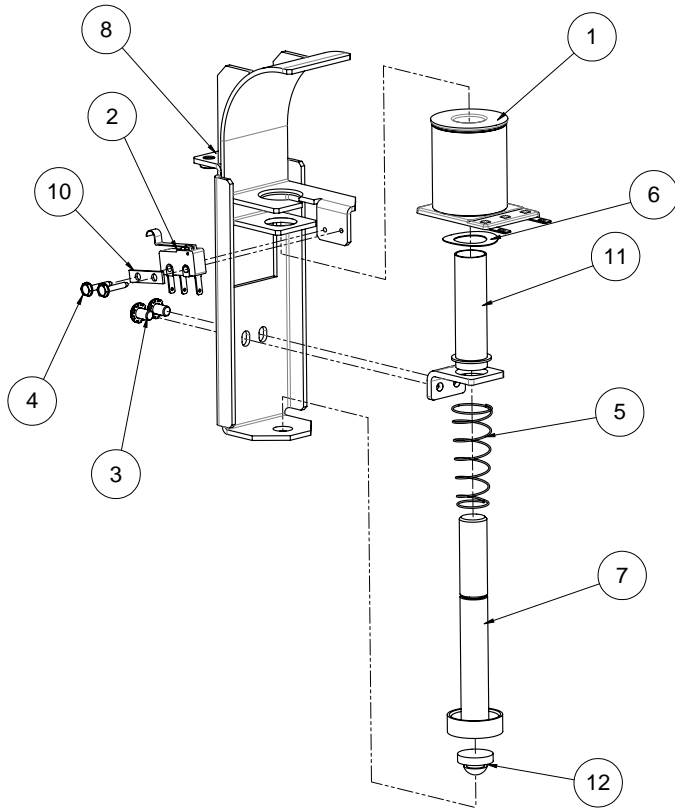

ID	Part Number	Description	Qty
1	090-5001-ND	COIL - 23-800, NO DIODE	1
2	180-5209-00	SUB MINIATURE SWITCH - SIM. ROLLER	1
3	232-5300-00	SCREW, 8-32 X 1/4" PPH SEMS	2
4	237-5937-02	SCREW, 2-56 X 1/2" HWH MS	2
5	266-5020-00	COMPRESSION SPRING-CONICAL	1
6	269-5002-00	SPRING WASHER	1
7	515-7309-00	PLUNGER ASSEMBLY	1
8	515-9984-00	BRACKET - EJECT - 2 FIN	1
9	535-5203-03	COIL RETAINING BRACKET	1
10	535-6539-00	SWITCH BODY PROTECT PLATE	1
11	545-5076-01	COIL SLEEVE	1
12	545-5105-00	RUBBER BUMPER	1

## 5.25 SUBWAY VUK ASSEMBLY

500-3655-00

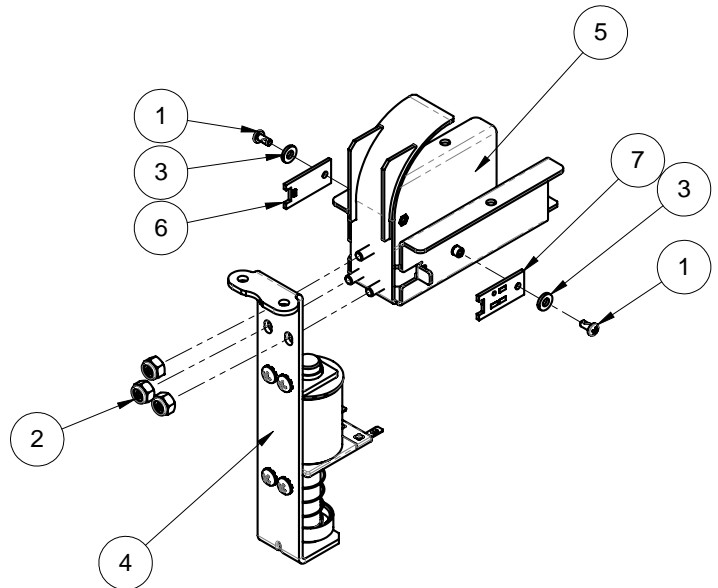

ID	Part Number	Description	Qty
1	237-6169-00P	SCREW, 4-40 X 1/4 PPH MS, PATCH	2
2	240-5102-00	8-32 NYLON LOCK NUT	3
3	242-5079-00	WASHER, .150 I.D. X .312 O.D. X .050 THICK	2
4	511-3672-00	SUBWAY VUK, POKÉMON	1
5	515-3026-00	TROUGH, VUK, POKÉMON	1
6	520-8115-00	PCA MINI SMT EMITTER	1
7	520-8116-00	PCA MINI SMT RECEIVER	1

## 5.26 MEOWTH TOPSIDE ASSEMBLY

500-9962-00

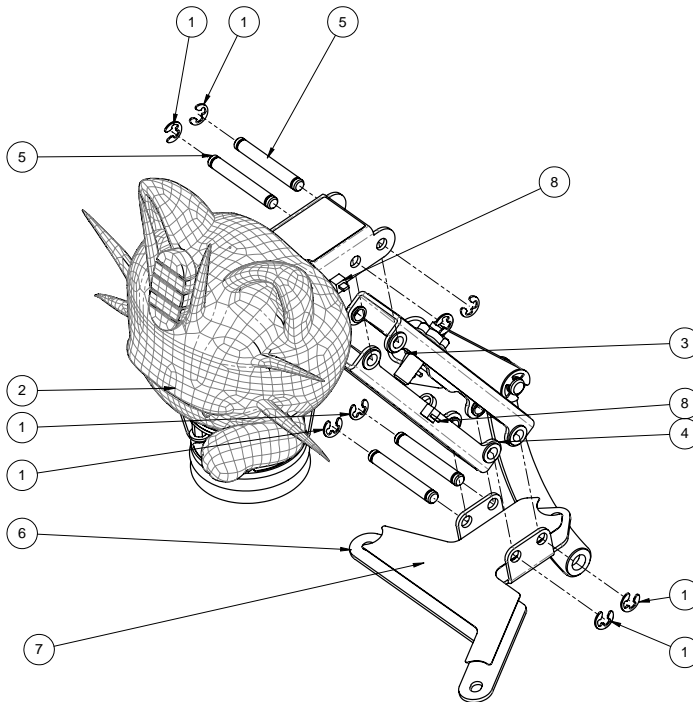

ID	Part Number	Description	Qty
1	270-5001-00	RETAINING E-RING, 3/16" SHAFT OD	8
2	511-8003-00	MEOWTH BALLOON MECH	1
3	511-8003-01	BACK LINK, POKÉMON	1
4	511-8003-07	FRONT MEOWTH LINK ASM	1
5	530-7812-14	PIVOT PIN-.188 DIA.	4
6	535-3381-10	MEOWTH MECH BRACKET	1
7	820-9313-06	DECAL, POKÉMON PREM/LE, -06	1
8	040-5001-02	5 1/2IN CABLE TIE (PLT1.5) BLACK	2

## 5.28 MEOWTH BALLOON MECH

511-8003-00

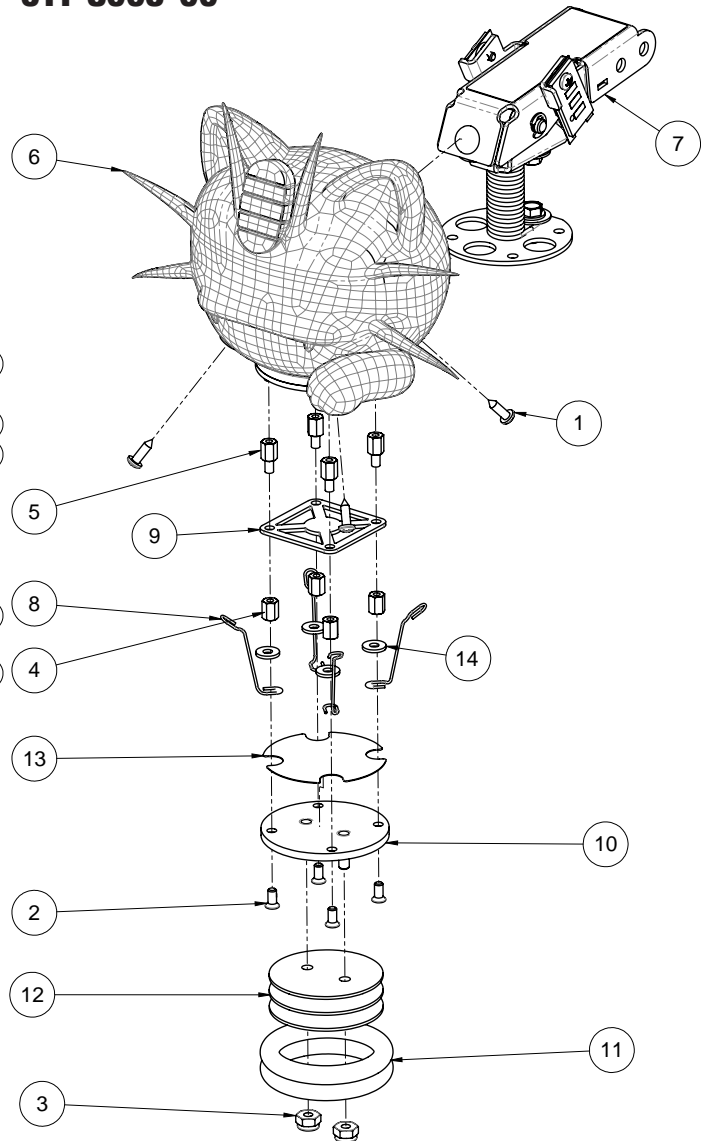

ID	Part Number	Description	Qty
1	237-5815-00	SCREW, #4 X 3/8" PPH AB	4
2	237-5983-02P	SCREW, 4-40 X 1/4" PFH MS, BLACK, PATCH	4
3	240-5005-00	6-32 NYLON STOP NUT	2
4	254-5428-06	HEX SPACER - 1/4 " 4-40 THREAD	4
5	254-5058-00	HEX SPACER MALE/FEMALE - 1/4"	4
6	510-2651-00	MEOWTH BALLOON RIVITED ASM	1
7	511-8003-06	MEOWTH PINNED ASM	1
8	535-3112-00	MEOWTH WIRE	4
9	535-3381-03	MEOWTH BALLOON CAGE	1
10	535-3381-14	MEOWTH BASKET TOP	1
11	545-5348-06	1-1/4" I.D. RUBBER RING - BLACK	2
12	544-1336-00	MEOWTH BASKET, MOLDED	1
13	820-9313-03	DECAL, POKÉMON PREM/LE, -03	1
14	242-5002-00	#4 FLAT WASHER - 5/16" O.D.	4
*	**	LOCTITE THREAD LOCK 243 "BLUE MED STR" P/N 24077	*

## 5.27 MEOWTH BUSHING CRADLE

511-8003-04

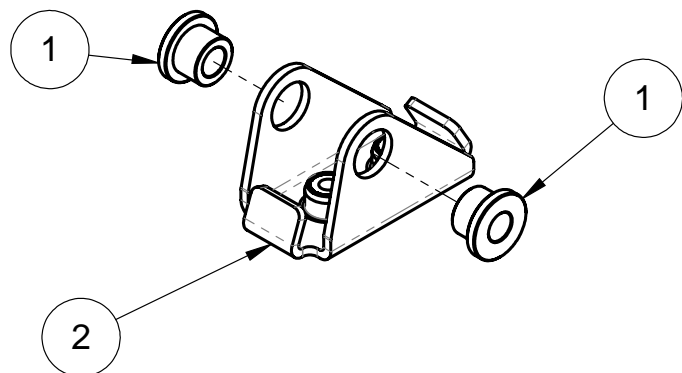

ID	Part Number	Description	Qty
1	283-5018-03	3/16 ID X 5/16 OD X 1/4 LG. BUNTING SAE 841 BRONZE FLANGED BEARING-PART #EF030504	2
2	535-3381-02	CRADLE, MEOWTH, POKÉMON	1

### 5.29 MEOWTH PINNED ASM

511-8003-06

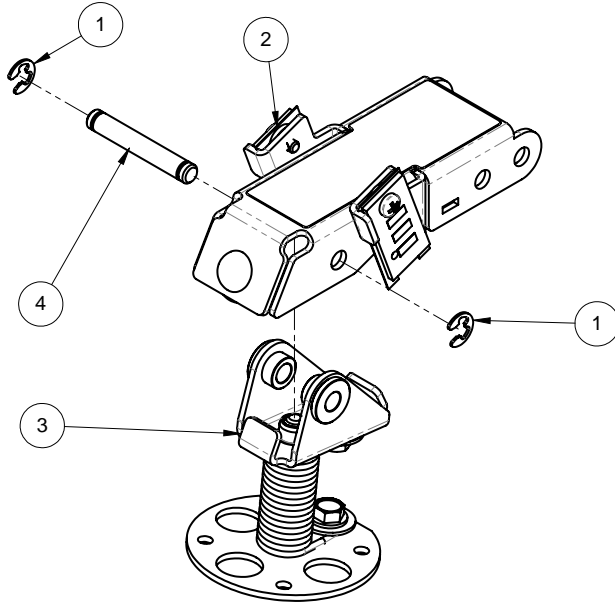

ID	Part Number	Description	Qty
1	270-5001-00	RETAINING E-RING, 3/16" SHAFT OD	2
2	511-8003-03	MEOWTH, TOP BRACKET	1
3	511-8003-05	MEOWTH, SPRING ASM	1
4	530-7812-01	PIVOT PIN-.188 DIA.	1

### 5.30 MEOWTH TOP BRACKET

511-8003-03

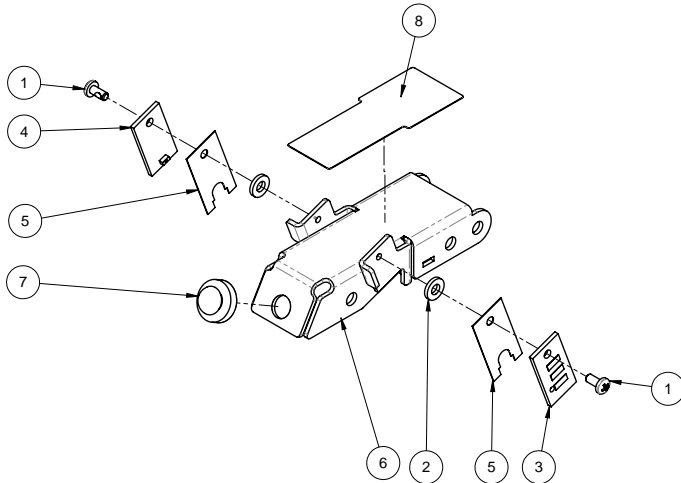

ID	Part Number	Description	Qty
1	237-6331-00P	SCREW, 4-40 X 1/4" PPH MS BLACK, PATCH	2
2	242-5079-00	WASHER, .150 I.D. X .312 O.D. X .050 THICK	2
3	520-8068-00	PCB, IR OPTO RECEIVER	1
4	520-8069-00	PCB, IR OPTO EMITTER	1
5	523-0033-00	FISCHE PAPER, MINI OPTOS	2
6	535-3381-01	MEOWTH BALOON, CRADLE, POKÉMON	1
7	545-5105-00	RUBBER BUMPER	1
8	820-9313-01	DECAL, POKÉMON PREM/LE, -01	1

### 5.31 BACK MEOWTH LINK ASM

511-8003-01

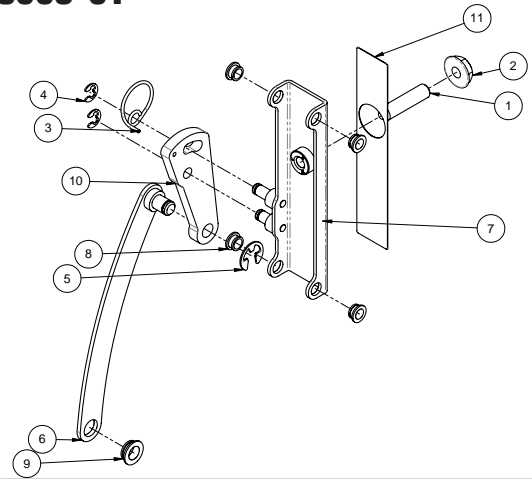

ID	Part Number	Description	Qty
1	237-6097-00	18-8 STAINLESS STEEL NYLON-TIP SET SCREW	1
2	240-5300-00	1/4-20 FLANGE NUT	1
3	266-5126-00	MEOWTH SPRING	1
4	270-5001-00	RETAINING E-RING, 3/16" SHAFT OD	2
5	270-5002-00	RETAINING RING - 1/4"	1
6	535-3381-06	MEOWTH LINK	1
7	535-3381-07	MEOWTH ARM	1
8	545-5352-00	NYLINER, 3/16" SHAFT	4
9	545-5423-00	NYLINER, 1/4" SHAFT, 4L1-FF	1
10	546-5039-00	MEOWTH LINK	1
11	820-9313-02	DECAL, POKÉMON PREM/LE, -02	1

### 5.32 FRONT MEOWTH LINK ASM

511-8003-07

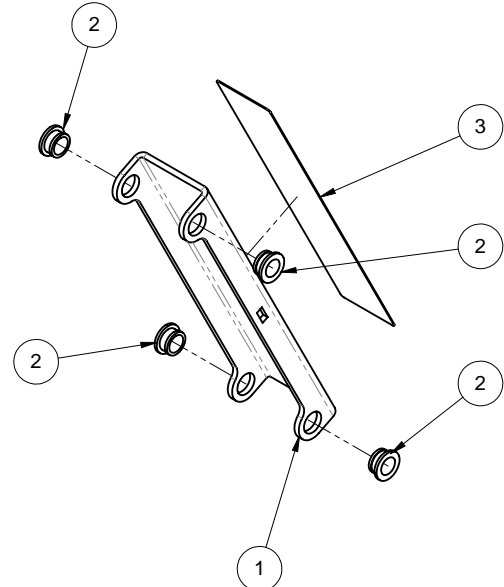

ID	Part Number	Description	Qty
1	535-3381-16	MEOWTH ARM	1
2	545-5352-00	NYLINER, 3/16" SHAFT	4
3	820-9313-04	DECAL, POKÉMON PREM/LE, -04	1



### 5.33 MEOWTH SPRING ASSEMBLY

511-8003-05

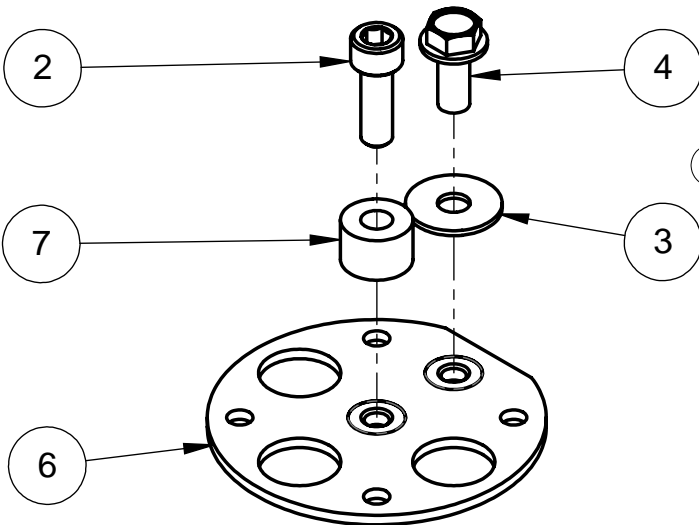
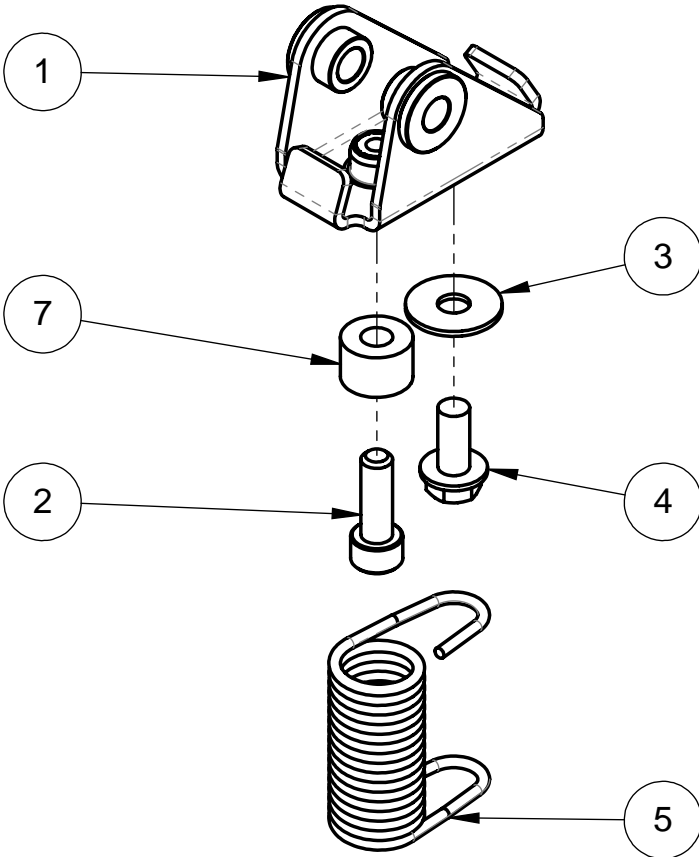

ID	Part Number	Description	Qty
1	511-8003-04	MEOWTH BUSHING CRADLE	1
2	237-6132-00	8-32 x 1/2 LG. SOC HD HEX, BLACK OXIDE	2
3	242-5015-00	#8 WASHER - .170 ID X 1/2 OD X .042	2
4	237-5879-00	#8-32 X 3/8 HWH ZINC	2
5	266-5107-02	ONE SIDED BUCKLING SPRING	1
6	535-3381-15	MEOWTH SPRING, BRACKET	1
7	530-7965-00	#8 SPACER, STAINLESS STEEL	2

### 5.34 MEOWTH MOTOR ASSEMBLY

500-9962-02

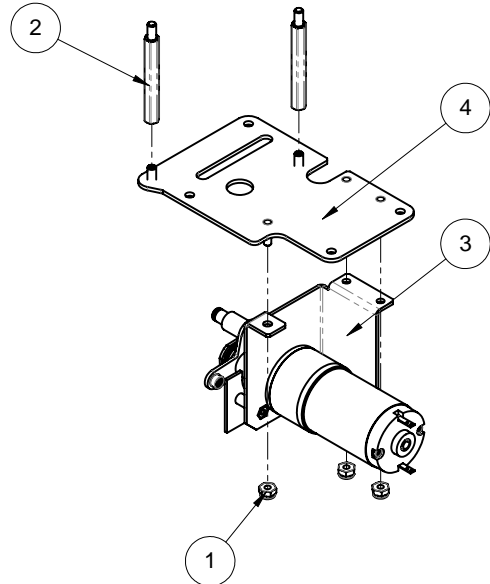

ID	Part Number	Description	Qty
1	240-5005-00	6-32 NYLON STOP NUT	3
2	254-5429-00	MALE-FEMALE THREADED HEX STANDOFF, 1-7/8" LONG	2
3	511-8003-02	MEOWTH MECH, MOTOR ASM	1
4	535-3381-13	MEOWTH BASE PLATE	1

### 5.35 MEOWTH MECH, MOTOR ASM

511-8003-02

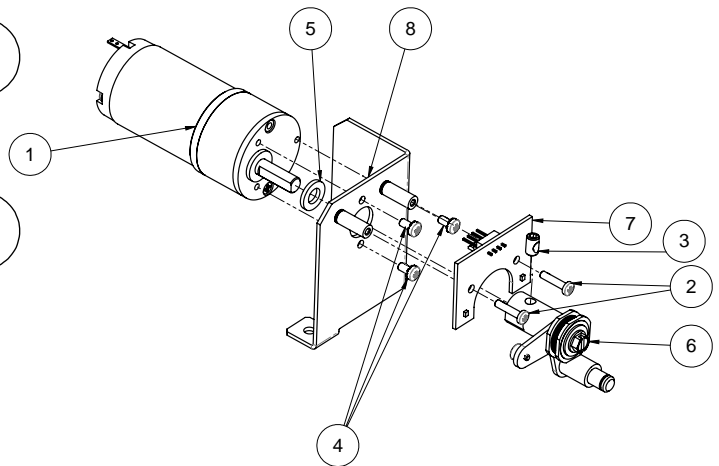

ID	Part Number	Description	Qty
1	041-5132-00	DC GEARHEAD MOTOR, 24 VDC 10 RPM	1
2	237-5816-00P	SCREW, 4-40 X 1/2" PPH, PATCH	2
3	237-6092-00P	SET SCREW, 10-32 X 5/16, SOCKET CUP PT, PATCH	1
4	237-6188-01P	SCREW, M3x0.5 X 6MM PPH SEMS ZINC, PATCH	3
5	242-5072-01	NYLON WASHER .252 ID X .472 OD	1
6	511-8003-08	CRANK ARM, POKÉMON	1
7	520-8470-00	PCA MAG SENSOR DUAL 180 OMNI	1
8	535-3381-12	MEOWTH MOTOR BRACKET	1

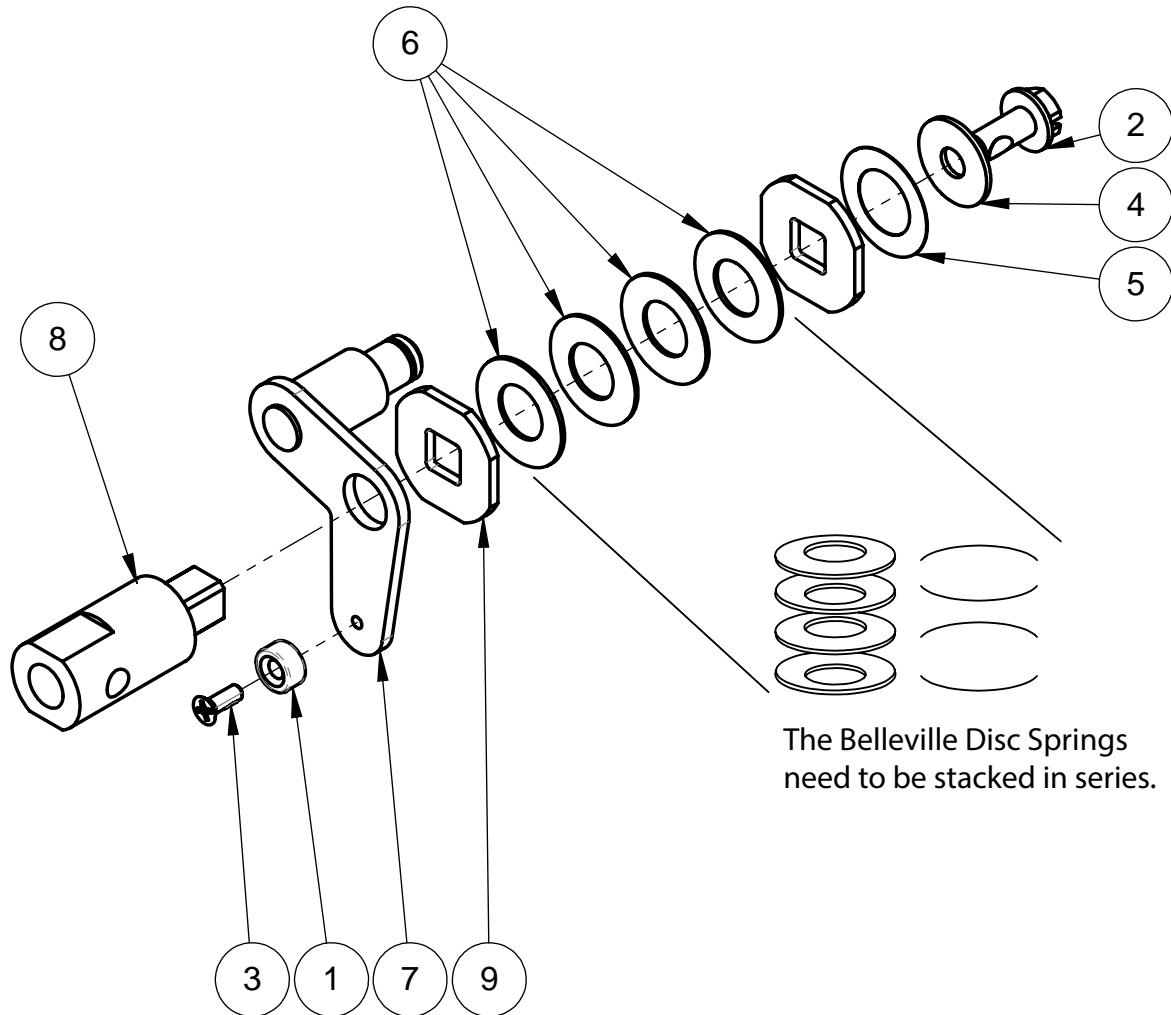
**5.36 CRANK ARM FOR MEOWTH MOTOR (HAS SPRING ORDER)****511-8003-08**

ID	Part Number	Description	Qty
1	090-5097-00	MAGNET, 1/4" X .125", #2 CSINK, AXIAL	1
2	237-5975-00P	SCREW, 8-32 X 3/8" HWH SWAGE ZN, PATCH	1
3	237-6366-00P	2-56 x 1/4" PFH MS, PATCH	1
4	242-5015-00	#8 WASHER - .170 ID X 1/2 OD X .042	1
5	242-5608-02	.005 SHIM WASHER	1
6	269-5007-00	BELLEVILLE DISC SPRING	4
7	515-3274-00	MEOWTH BALLOON CRANK ARM	1
8	530-7808-07	HUB - CLUTCH DRIVE	1
9	535-0612-00	DRIVE PLATE	2

### 5.37 MEOWTH BALLOON ASSEMBLY (REPLACEMENT VERSION)

511-4959-00

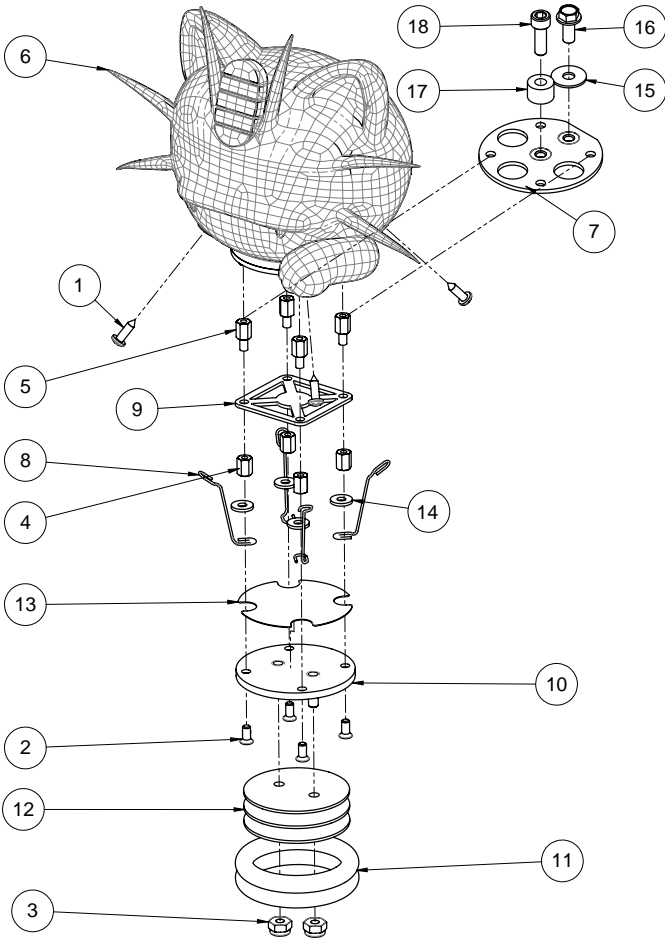

ID	Part Number	Description	Qty
1	237-5815-00	SCREW, #4 X 3/8" PPH AB	4
2	237-5983-02P	SCREW, 4-40 x 1/4" PFH MS, BLACK, PATCH	4
3	240-5005-00	6-32 NYLON STOP NUT	2
4	254-5428-06	HEX SPACER - 1/4 " 4-40 THREAD	4
5	254-5058-00	HEX SPACER MALE/FEMALE - 1/4"	4
6	510-2651-00	MEOWTH BALLOON RIVITED ASM	1
7	535-3381-15	MEOWTH SPRING, BRACKET	1
8	535-3112-00	MEOWTH WIRE	4
9	535-3381-03	MEOWTH BALLOON CAGE	1
10	535-3381-14	MEOWTH BASKET TOP	1
11	545-5348-06	1-1/4" I.D. RUBBER RING - BLACK	2
12	544-1336-00	MEOWTH BASKET, MOLDED	1
13	820-9313-03	DECAL, POKÉMON PREM/LE, -03	1
14	242-5002-00	#4 FLAT WASHER - 5/16" O.D.	4
15	242-5015-00	#8 WASHER - .170 ID X 1/2 OD X .042	2
16	237-5879-00	#8-32 X 3/8 HWH ZINC	2
17	530-7965-00	#8 SPACER, STAINLESS STEEL	2
18	237-6132-00	8-32 x 1/2 LG. SOC HD HEX, BLACK OXIDE	2
*	**	LOCTITE THREAD LOCK 243 "BLUE MED STR" P/N 24077	*

### 5.38 BALL GUIDE -02 ASSEMBLY WITH SPINNER

511-3237-02

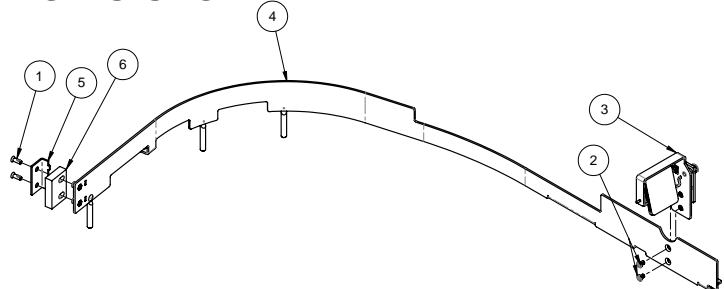

ID	Part Number	Description	Qty
1	237-6151-00P	SCREW, 4-40 X 5/16" PFH U/C MS	2
2	237-6197-00P	SCREW, 4-40 X 3/16 PFH U/C 18-8 SS, PATCH	2
3	511-5715-00	ASSEMBLY, REFLECTIVE OPTO SPINNER, BALL GUIDE MOUNT	1
4	535-4187-02	BALL GUIDE, -02, POKÉMON	1
5	535-9366-01	BUMPER HOLDER	1
6	626-5057-01	GUIDE BUMPER	1

### 5.39 REFLECTIVE OPTO SPINNER, BALL GUIDE MOUNT

511-5715-00

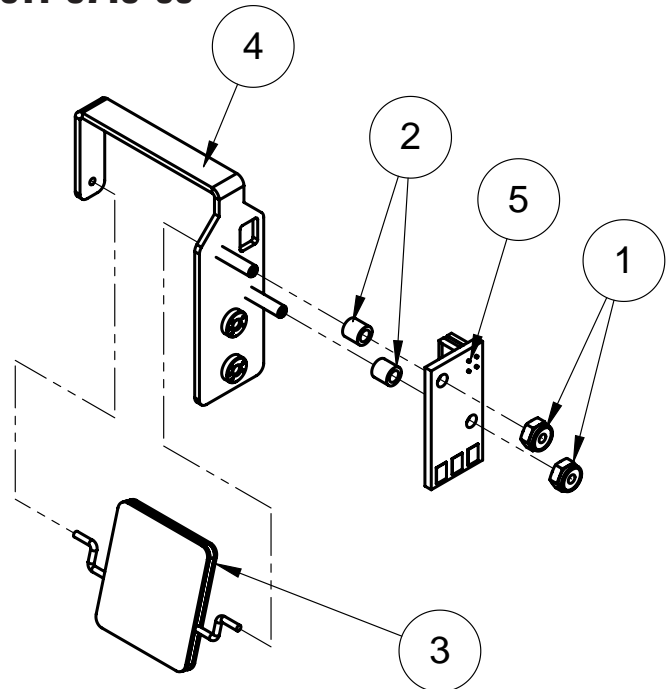

ID	Part Number	Description	Qty
1	240-5303-00	4-40 NYLON LOCK NUT	2
2	254-5090-01	PLASTIC SPACER #4 SCREW, 3/16" OD - 3/16" LENGTH	2
3	515-2326-00	SPINNER TARGET, REFLECTIVE OPTO	1
4	515-1241-00	BRACKET, SPINNER, REFLECTIVE OPTO, SIDE MOUNT	1
5	520-8541-00	PCA SPINNER REFLECTIVE OPTIC	1

### 5.40 BALL GUIDE -04 ASSEMBLY

511-3237-04

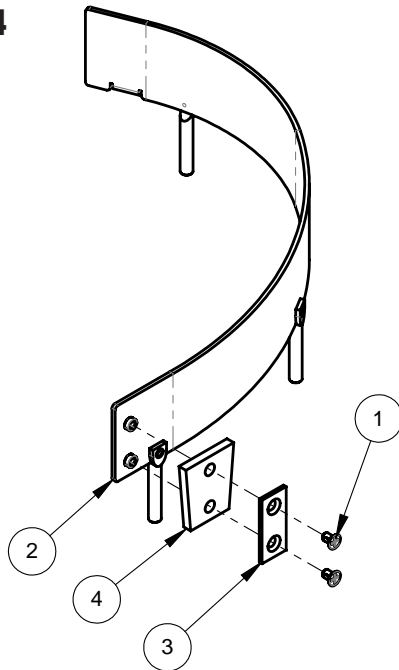

ID	Part Number	Description	Qty
1	237-6197-00P	SCREW, 4-40 X 3/16 PFH U/C 18-8 SS, PATCH	2
2	535-4187-04	BALL GUIDE, -04, POKÉMON	1
3	535-9648-00	BUMPER HOLDER - FASTENED	1
4	626-5067-01	RUBBER BUMPER - BLACK - FASTENED	1

### 5.41 BALL GUIDE -06 ASSEMBLY

511-3237-06

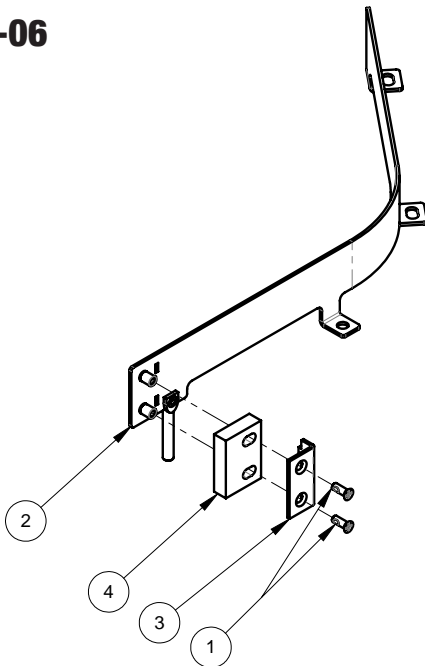

ID	Part Number	Description	Qty
1	237-6151-00P	SCREW, 4-40 X 5/16" PFH U/C MS	2
2	535-4187-06	BALL GUIDE, -06, POKÉMON	1
3	535-9366-01	BUMPER HOLDER	1
4	626-5057-01	GUIDE BUMPER	1

### 5.42 BALL GUIDE -12 ASSEMBLY

511-3237-12

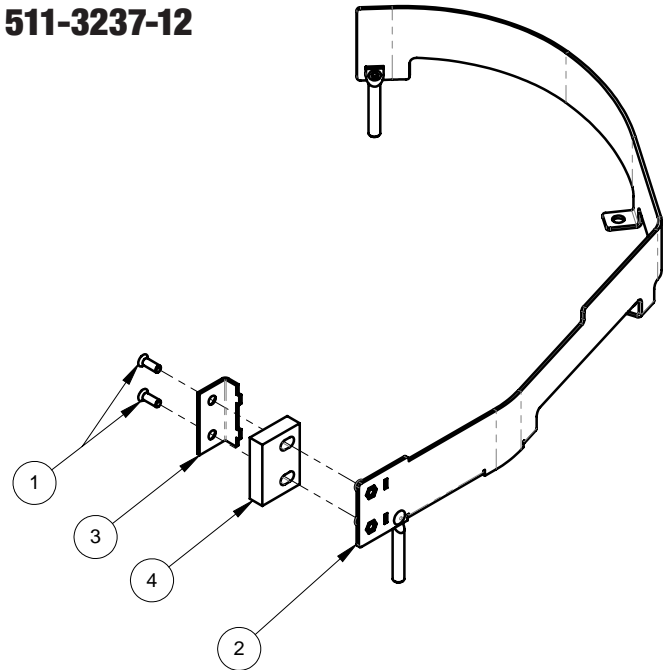

ID	Part Number	Description	Qty
1	237-6151-00P	SCREW, 4-40 X 5/16" PFH U/C MS	2
2	535-4187-12	BALL GUIDE, -12, POKÉMON	1
3	535-9366-01	BUMPER HOLDER	1
4	626-5057-01	GUIDE BUMPER	1

### 5.43 BALL GUIDE -15 ASSEMBLY

511-3237-15

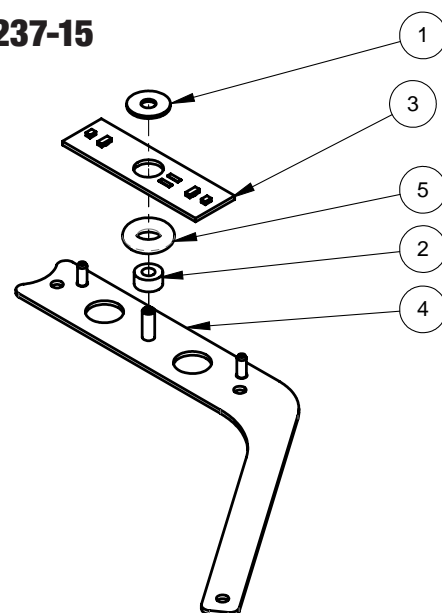

ID	Part Number	Description	Qty
1	242-5617-00	WASHER, #10 NYLON 6/6	1
2	254-5000-18	NYLON SPACER - BLACK - 3/8 OD X .175 ID X 3/16"	1
3	520-8652-00	LAMP BOARD, 4-LED WHITE, RETURN LANE	1
4	535-4187-15	BALL GUIDE, -15, POKÉMON	1
5	545-5348-02	5/16 ID RUBBER RING	1



### 5.44 BALL GUIDE -16 ASSEMBLY

511-3237-16

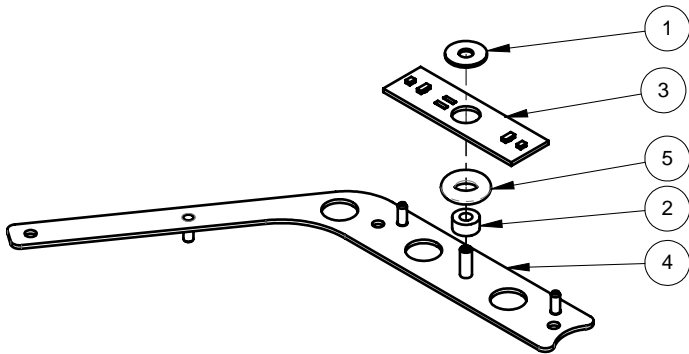

ID	Part Number	Description	Qty
1	242-5617-00	WASHER, #10 NYLON 6/6	1
2	254-5000-18	NYLON SPACER - BLACK - 3/8 OD X .175 ID X 3/16"	1
3	520-8652-00	LAMP BOARD, 4-LED WHITE, RETURN LANE	1
4	535-4187-16	BALL GUIDE, -16, POKÉMON	1
5	545-5348-02	5/16 ID RUBBER RING	1

### 5.45 NEWTON BALL SWITCH ASSEMBLY

511-6790-00

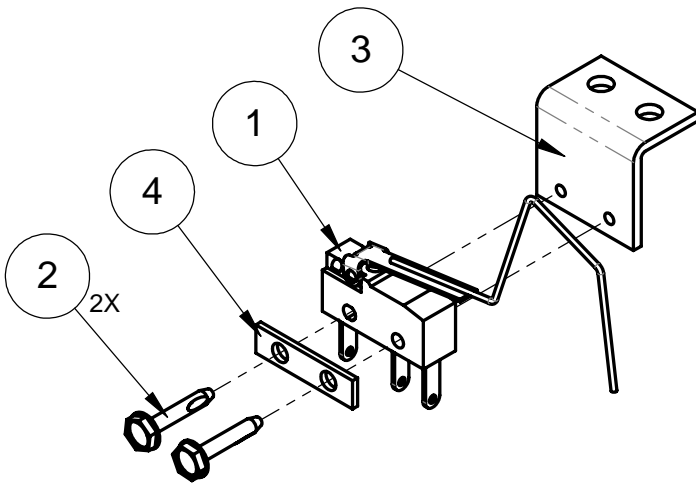

ID	Part Number	Description	Qty
1	180-5178-00	MICRO-SWITCH, INLINE WIRE	1
2	237-5937-02P	SCREW, 2-56 X 1/2" HWH MS, PATCH	2
3	535-6173-06	MICRO-SWITCH BRACKET	1
4	535-6539-00	SWITCH BODY PROTECT PLATE	1

### 5.46 3-TARGET STAND UP BANK WITH LED PCB (BATTLE)

511-3284-00

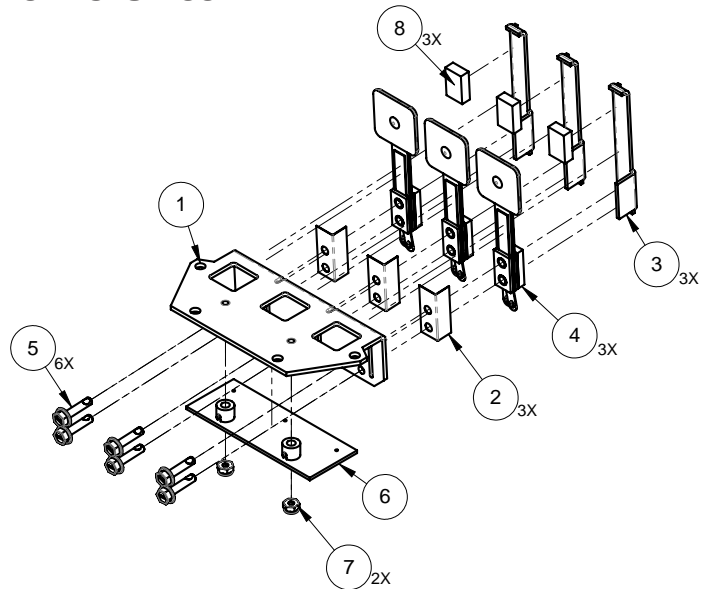

ID	Part Number	Description	Qty
1	535-3409-00	BRACKET, 3 STANDUP BANK	1
2	545-7874-00	FISCHE PAPER - S/U TARGET	3
3	535-9823-02	SWITCH BACK PLATE - LOCKING	3
4	515-9783-00-00	1" SQ. TARGET SWITCH - ANTILOFT- 2 LUG - BLACK	3
5	237-5976-04P	SCREW, 6-32 X 5/8" HWH SWAGE, SERRATED, PATCH	6
6	520-9885-00	LED BOARD - 3R TC	1
7	240-5303-00	4-40 NYLON LOCK NUT	2
8	626-5078-00	3/16" FOAM PAD	3

### 5.47 R/U SWITCH GATE ASSEMBLY

511-4903-02

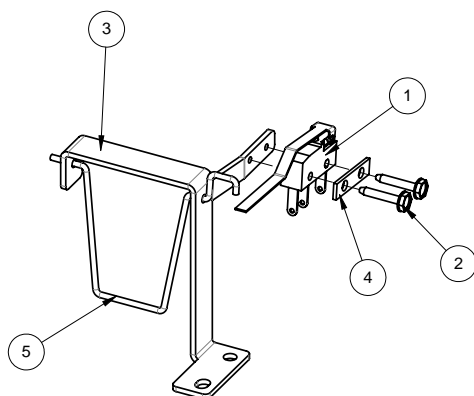

ID	Part Number	Description	Qty
1	180-5087-00	SWITCH - GATE	1
2	237-5937-02P	SCREW, 2-56 X 1/2" HWH MS, PATCH	2
3	535-3394-02	BRACKET, R/U SWITCH, FLOOR MTG., RIGHT	1
4	535-6539-00	SWITCH BODY PROTECT PLATE	1
5	535-7755-02	WIRE FORM	1

# 5.48 PIKACHU RAMP ASSEMBLY

500-1216-00

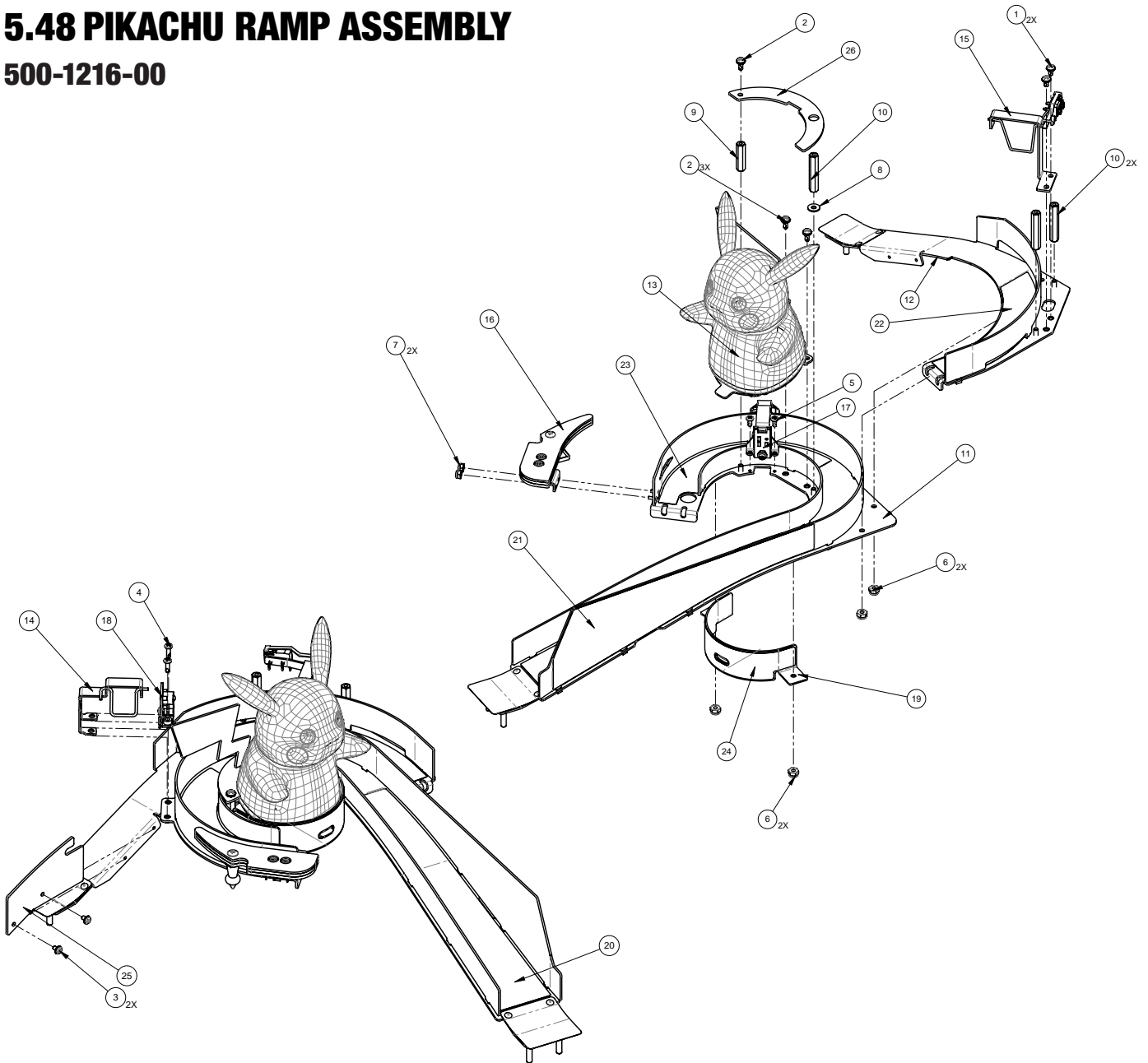

ID	PART NUMBER	DESCRIPTION	QTY
1	232-5200-00P	SCREW, 6-32 X 1/4" PPH SEMS, PATCH	2
2	232-5208-00P	SCREW, 6-32 X 5/16" PPH SEMS, PATCH	3
3	237-5884-00P	SCREW, 4-40 X 3/16" PPH SEMS, PATCHED	2
4	237-5997-00P	SCREW, 4-40 X 3/8" PPH MS BLACK, PATCH	2
5	237-6169-00P	SCREW, 4-40 X 1/4 PPH MS, PATCH	2
6	240-5005-00	6-32 NYLON STOP NUT	4
7	240-5321-00	2-56 NYLON LOCK NUT	2
8	242-5001-00	#6 WASHER	1
9	254-5008-06	HEX SPACER - 1"	1
10	254-5008-33	HEX SPACER - 1 3/8"	3
11	510-7996-00	RIVETED ASSEMBLY, METAL RAMP	1
12	510-7996-01	RIVETED ASSEMBLY, METAL RAMP	1
13	511-1192-00	PIKACHU MECH ASSEMBLY, POKÉMON PREM/LE	1

ID	PART NUMBER	DESCRIPTION	QTY
14	511-3692-00	ONE WAY GATE, POKÉMON	1
15	511-4903-02	ASSEMBLY, R/U SWITCH, FLOOR MTG., RIGHT, NARROW	1
16	511-7325-00	ASSEMBLY, SIDE MOUNT SWITCH, POKÉMON	1
17	511-7326-00	ASSEMBLY, OPTO RECEIVER, POKÉMON	1
18	515-0215-00	LONG RANGE OPTO EMITTER ASSEMBLY	1
19	535-2915-00	PIKA FRONT WALL	1
20	820-9313-05	DECAL, POKÉMON PREM/LE, -05	1
21	820-9313-07	DECAL, POKÉMON PREM/LE, -07	1
22	820-9313-12	DECAL, POKÉMON PREM/LE, -12	1
23	820-9313-13	DECAL, POKÉMON PREM/LE, -13	1
24	820-9313-15	DECAL, POKÉMON PREM/LE, -15	1
25	830-5024-31	PLASTIC, POKÉMON, -31	1
26	830-5024-34	PLASTIC, POKÉMON, -34	1



©2026 Pokémon. ©1995-2026 Nintendo / Creatures Inc. / GAME FREAK inc. TM, ®, and character names are trademarks of Nintendo.

**5.49 ONE WAY GATE (PIKACHU RAMP)**  
511-3692-00

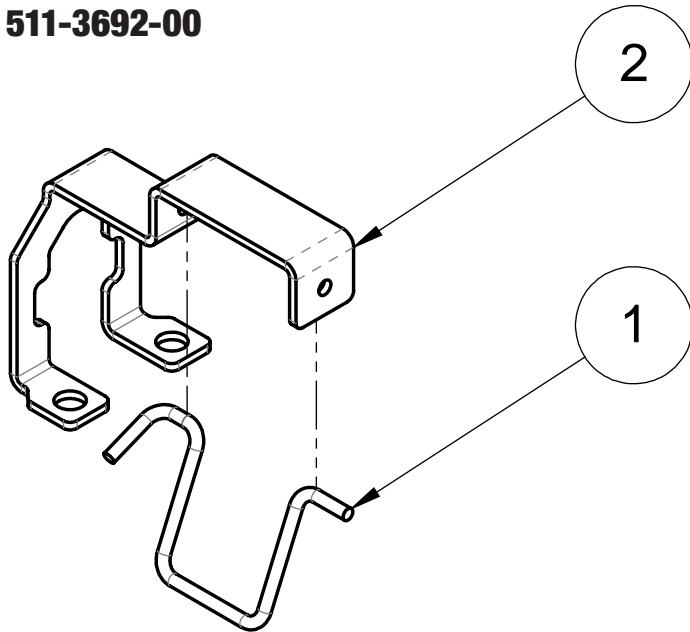

ID	Part Number	Description	Qty
1	535-0288-00	WIRE, ONE-WAY GATE, CSI	1
2	535-2933-00	ONE WAY GATE, POKÉMON	1

**5.50 OPTO RECEIVER ASSEMBLY (PIKACHU RAMP)**  
511-7326-00

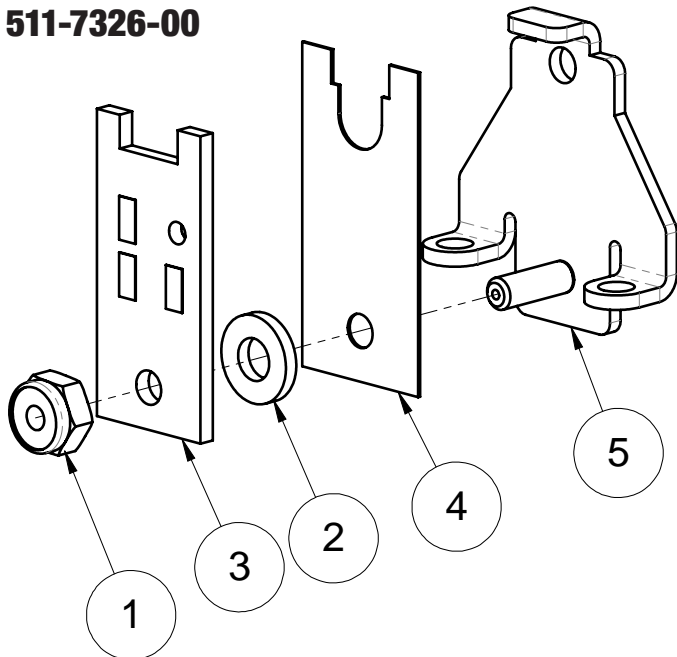

ID	Part Number	Description	Qty
1	240-5303-00	4-40 NYLON LOCK NUT	1
2	242-5079-00	WASHER, .150 I.D. X .312 O.D. X .050 THICK	1
3	520-8116-00	PCA MINI SMT RECEIVER	1
4	523-0033-00	FISCHE PAPER, MINI OPTOS	1
5	535-3272-00	BRACKET, MINI OPTO RECEIVER, POKÉMON	1

**5.51 UP POST ASSEMBLY, LONG (PIKACHU RAMP)**  
500-3661-00

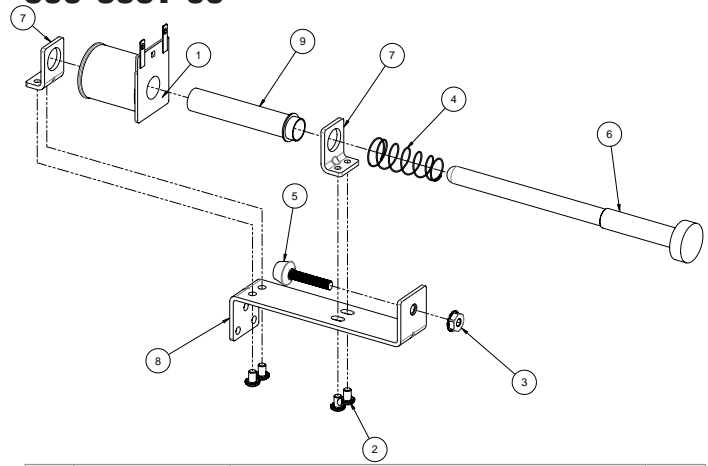

ID	Part Number	Description	Qty
1	090-5044-ND	COIL 26-1200 - NO DIODE	1
2	232-5300-00P	SCREW, 8-32 X 1/4" PPH SEMS, PATCH	4
3	240-5208-00	10-32 KEPS NUT	1
4	266-5020-00	COMPRESSION SPRING-CONICAL	1
5	280-5014-00	ADJUSTABLE BUMPER/STOP	1
6	515-3281-00	PLUNGER ASSEMBLY, PINNED, PLASTIC, 4" UP-POST	1
7	535-5203-03	COIL RETAINING BRACKET	2
8	535-9248-00	BRACKET	1
9	545-5847-00	COIL SLEEVE	1

**5.52 SERVO MOTOR BOARD ASM**  
500-5037-00

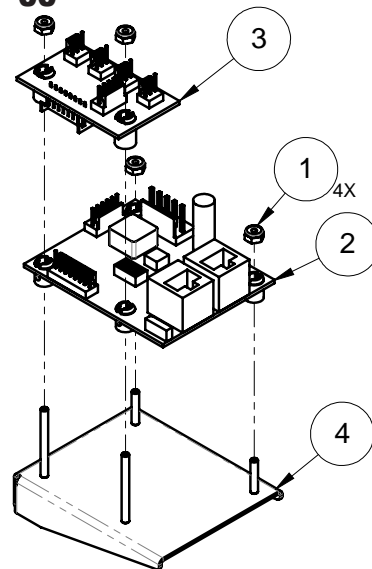

ID	Part Number	Description	Qty
1	240-5303-00	4-40 NYLON LOCK NUT	4
2	520-5370-72	SPI NODE BOARD W/ PWM	1
3	520-8685-00	MULTI-SERVO INTERFACE SPI BOARD	1
4	535-3105-00	SERVO BRACKET	1

### 5.53 PIKACHU MECH ASSEMBLY

511-1192-00

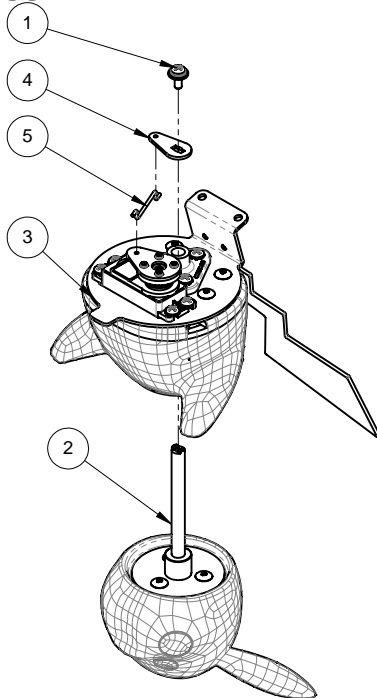

ID	Part Number	Description	Qty
1	237-6378-00P	#6-32 X 3/8 PAN PHILLIPS W/DOUBLE SEMS, PATCH	1
2	510-8022-02	RIVETED ASM PIKACHU HEAD, POKÉMON	1
3	511-1193-00	PIKACHU BODY ASSEMBLY, POKÉMON PREM/LE	1
4	535-2914-00	PIKA CRANK ARM	1
5	535-2920-00	PIKA SERVO WIRE	1

### 5.54 SERVO HORN ASSEMBLY

511-4605-51

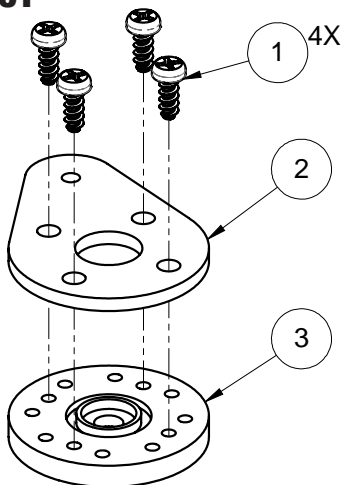

ID	Part Number	Description	Qty
1	237-6400-00	M2 X 5MM PH-RH SS TF SCR FOR PLASTIC	4
2	535-3093-21	SERVO ARM, WIRE, 15.18MM	1
3	545-1133-01	RC SERVO HORN ROUND	1

### 5.55 PIKACHU BODY ASSEMBLY

511-1193-00

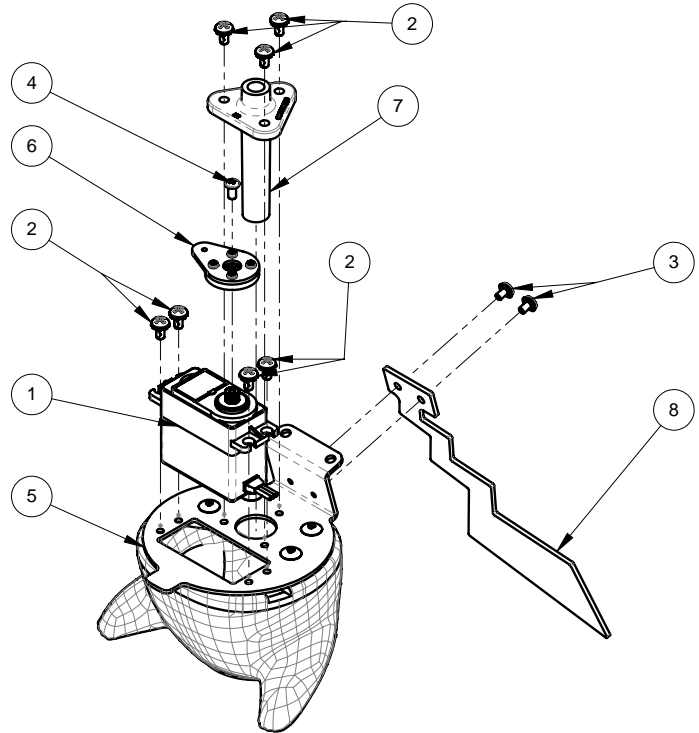

ID	Part Number	Description	Qty
1	041-5148-00	RC SERVO MOTOR	1
2	232-5200-00P	SCREW, 6-32 X 1/4" PPH SEMS, PATCH	7
3	237-5884-00P	SCREW, 4-40 X 3/16" PPH SEMS, PATCH	2
4	237-6367-00	SCREW, M3 X 6MM, PPH, SERVO	1
5	510-8022-01	RIVETED ASM PIKACHU BODY, POKÉMON	1
6	511-4605-51	ASM, SERVO HORN, KONG BODY	1
7	544-0133-00	BUSHING, HORIZONTAL SPINNER	1
8	830-5024-30	PLASTIC, POKÉMON, -30	1



### 5.56 SIDE MOUNT SWITCH ASSEMBLY

511-7325-00

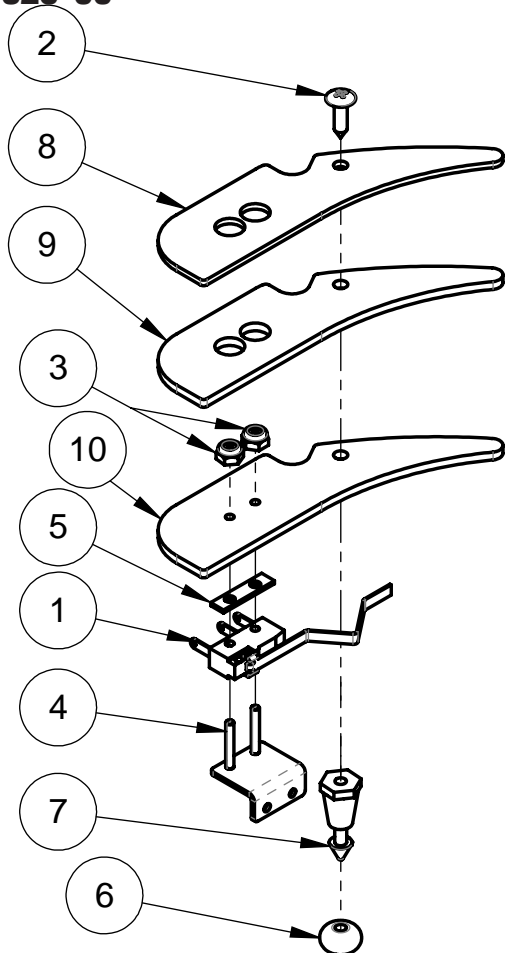

ID	Part Number	Description	Qty
1	180-5183-00	SWITCH - SCOOP	1
2	237-5809-00	SCREW, #6 X 1/2" PTH A	1
3	240-5321-00	2-56 NYLON LOCK NUT	2
4	535-2916-00	BRACKET, MICRO-SWITCH, SIDE MOUNT	1
5	535-6539-00	SWITCH BODY PROTECT PLATE	1
6	545-5348-17	7/16 O.D. RUBBER RING - BLACK	1
7	550-5052-01	MINI POST - CLEAR	1
8	830-5024-15	PLASTIC, POKÉMON, -15	1
9	830-6982-35	PLASTIC 100, POKÉMON, -35	1
10	830-6982-45	PLASTIC 100, POKÉMON, -45	1

### 5.57 POKÉ BALL RAMP COIL ASSEMBLY

500-9962-01

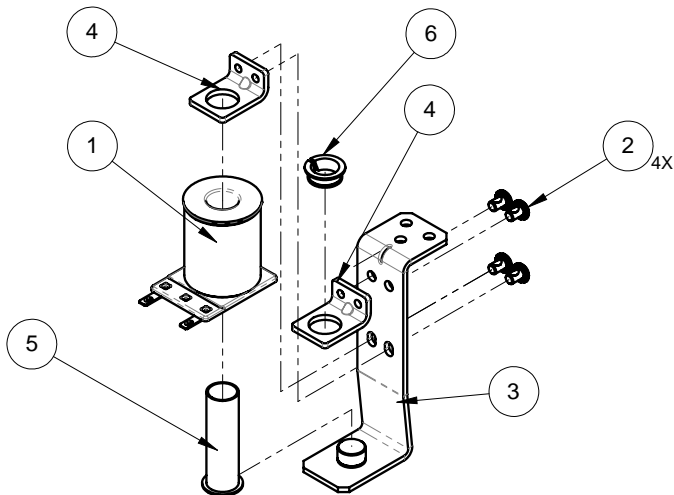

ID	Part Number	Description	Qty
1	090-5044-ND	COIL 26-1200 - NO DIODE	1
2	232-5300-00P	SCREW, 8-32 X 1/4" PPH SEMS, PATCH	4
3	515-2199-00	DOWN POST BRKT ASM	1
4	535-5203-03	COIL RETAINING BRACKET	2
5	545-5411-00	COIL SLEEVE	1
6	545-5418-01	NYLINER - PLASTIC, 7/16"	1

### 5.58 PLASTIC 01 ASSEMBLY

511-3238-01

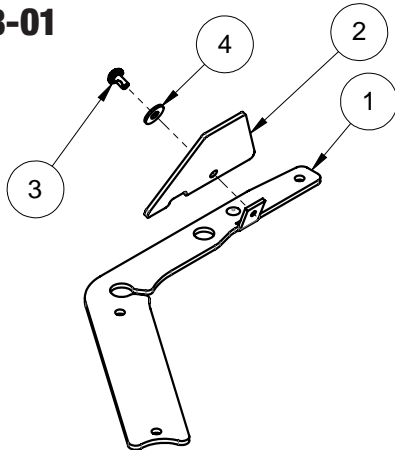

ID	Part Number	Description	Qty
1	510-2645-01	RIVETED PLASTIC ASSEMBLY -01, POKÉMON PREM/LE	1
2	830-5024-23	PLASTIC, POKÉMON, -23	1
3	232-5200-00P	SCREW, 6-32 X 1/4" PPH SEMS, PATCH	1
4	242-5001-00	#6 WASHER	1

### 5.59 PLASTIC 02 ASSEMBLY

511-3238-02

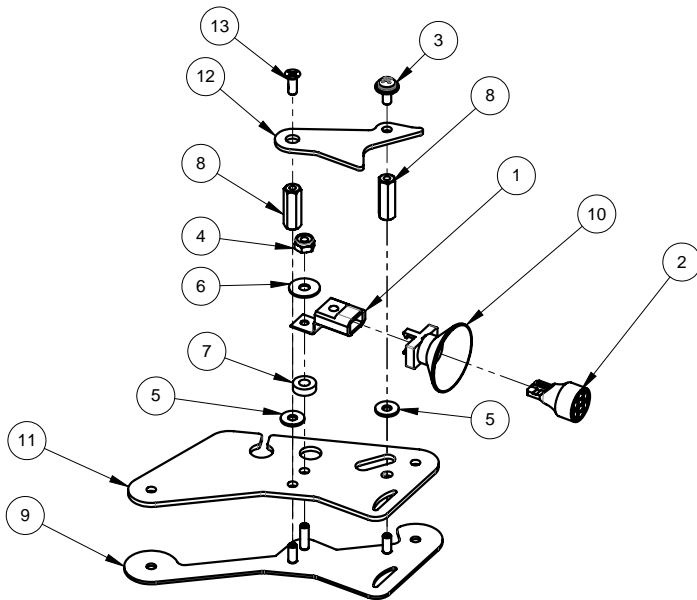

ID	Part Number	Description	Qty
1	077-5026-01	SOCKET, L/D WEDGE BASE BLACK	1
2	113-5032-08	8 ELEMENT FLAT W-BASE LED 5V AC - WHITE	1
3	237-6378-00P	#6-32 X 3/8 PAN PHILLIPS W/DOUBLE SEMS, PATCH	1
4	240-5005-00	6-32 NYLON STOP NUT	1
5	242-5001-00	#6 WASHER	2
6	242-5015-00	#8 WASHER - .170 ID X 1/2 OD X .042	1
7	254-5000-19	NYLON SPACER - BLACK - 3/8 OD X .175 ID X 1/8"	1
8	254-5008-04	HEX SPACER - 3/4 "	2
9	535-3110-00	PROTECTOR, LEFT SLING, POKÉMON	1
10	545-5409-01	REFLECTOR	1
11	830-5024-02	PLASTIC, POKÉMON, -02	1
12	830-5024-18	PLASTIC, POKÉMON, -18	1
13	237-5871-00P	SCREW, 6-32 X 3/8" PFH 82° U/C ZINC, PATCH	1

### 5.60 PLASTIC 04 ASSEMBLY

511-3238-04

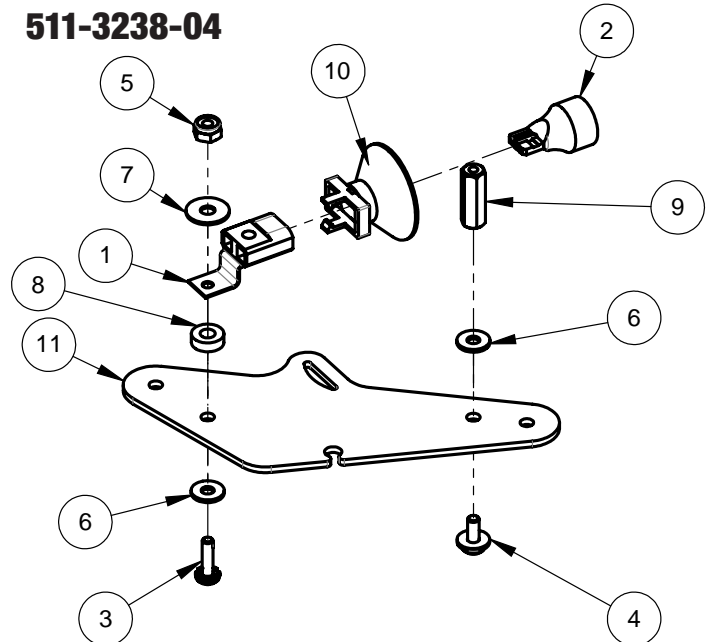

ID	Part Number	Description	Qty
1	077-5026-01	SOCKET, L/D WEDGE BASE BLACK	1
2	113-5032-08	8 ELEMENT FLAT W-BASE LED 5V AC - WHITE	1
3	232-5202-00P	SCREW, 6-32 X 1/2" PPH MS SEMS, PATCH	1
4	237-6378-00P	#6-32 X 3/8 PAN PHILLIPS W/DOUBLE SEMS, PATCH	1
5	240-5005-00	6-32 NYLON STOP NUT	1
6	242-5001-00	#6 WASHER	2
7	242-5015-00	#8 WASHER - .170 ID X 1/2 OD X .042	1
8	254-5000-19	NYLON SPACER - BLACK - 3/8 OD X .175 ID X 1/8"	1
9	254-5008-04	HEX SPACER - 3/4 "	1
10	545-5409-01	REFLECTOR	1
11	830-5024-04	PLASTIC, POKÉMON, -04	1

### 5.61 PLASTIC 09 ASSEMBLY

511-3238-09

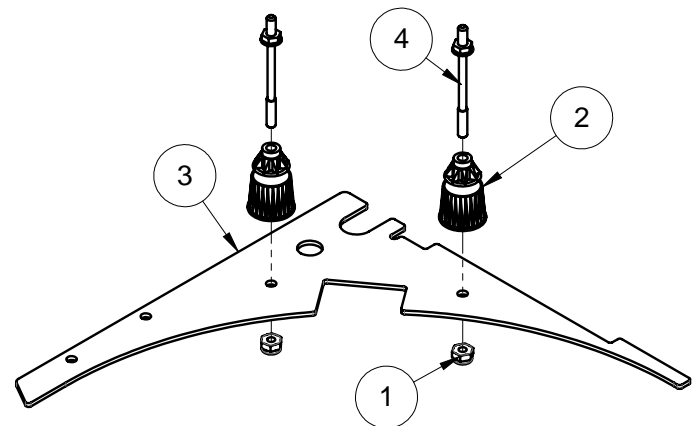

ID	Part Number	Description	Qty
1	240-5005-00	6-32 NYLON STOP NUT	2
2	550-5034-02	GROOVED JEWEL PLASTIC POST, RED	2
3	830-5024-09	PLASTIC, POKÉMON, -09	1
4	530-5012-02	6-32 POST SCREW	2



## 5.62 PLASTIC 05 ASSEMBLY

511-3238-05

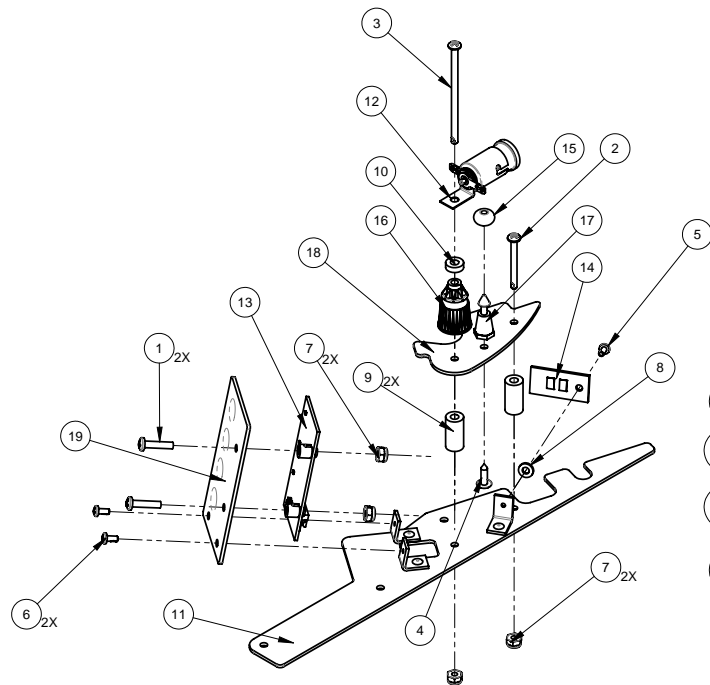

ID	Part Number	Description	Qty
1	237-5503-01P	SCREW, 6-32 X 5/8" PPH MS BLACK, PATCH	2
2	237-5508-00P	SCREW, 6-32 X 1-1/4 PPH MS, PATCH	1
3	237-5514-01P	SCREW, 6-32 X 2-1/2" PPH MS, PATCH	1
4	237-5809-00	SCREW, #6 X 1/2" PTH A	1
5	237-6169-00P	SCREW, 4-40 X 1/4 PPH MS, PATCH	1
6	237-6331-00P	SCREW, 4-40 X 1/4" PPH MS BLACK, PATCH	2
7	240-5005-00	6-32 NYLON STOP NUT	4
8	242-5079-00	WASHER, .150 I.D. X .312 O.D. X .050 THICK	1
9	254-5000-07	NYLON SPACER - BLACK - 3/8 OD X .175 ID X 3/4"	2
10	254-5000-19	NYLON SPACER - BLACK - 3/8 OD X .175 ID X 1/8"	1
11	510-2645-05	RIVETED PLASTIC ASSEMBLY -05, PREMIUM, POKÉMON	1
12	518-5045-08-LED	MULTI FLASHER 5V LED ASSEMBLY - WHITE	1
13	520-1076-00	PCA BILL-BRD MINI-PLYFLD 4-LED	1
14	520-7000-00	SINGLE FLASH LED BOARD	1
15	545-5348-17	7/16 O.D. RUBBER RING - BLACK	1
16	550-5034-02	GROOVED JEWEL PLASTIC POST, RED	1
17	550-5052-01	MINI POST - CLEAR	1
18	830-5024-24	PLASTIC, POKÉMON, -24	1
19	830-5024-98	PLASTIC, POKÉMON, -98	1

## 5.63 PLASTIC 06 ASSEMBLY

511-3238-06

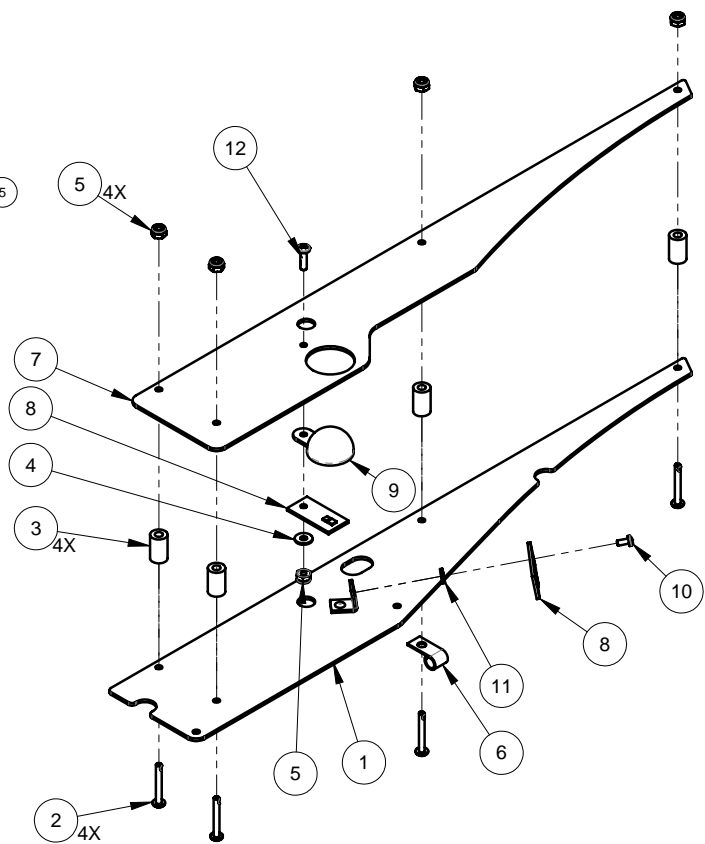

ID	Part Number	Description	Qty
1	510-2645-06	RIVETED PLASTIC ASSEMBLY -06, POKÉMON PREM/LE	1
2	237-5506-00P	SCREW, 6-32 X 1" PPH MS, PATCH	4
3	254-5000-14	NYLON SPACER - BLACK - 3/8 OD X .175 ID X 5/8"	4
4	242-5001-00	#6 WASHER	1
5	240-5005-00	6-32 NYLON STOP NUT	5
6	040-5000-03	1/4" CABLE CLAMP	1
7	830-5024-25	PLASTIC, POKÉMON, -25	1
8	520-7000-00	SINGLE FLASH LED BOARD	2
9	550-5510-05	HAT - TRIMMED - BLUE SB	1
10	237-6169-00P	SCREW, 4-40 X 1/4 PPH MS, PATCH	1
11	242-5079-00	WASHER, .150 I.D. X .312 O.D. X .050 THICK	1
12	237-5502-00P	SCREW, 6-32 X 1/2" PPH MS ZINC, PATCH	1

### 5.64 PLASTIC 10 ASSEMBLY

511-3238-10

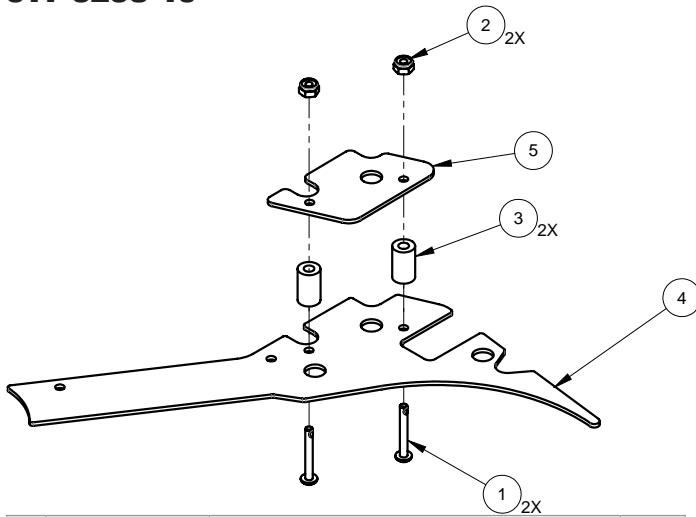

ID	Part Number	Description	Qty
1	237-5506-00P	SCREW, 6-32 X 1" PPH MS, PATCH	2
2	240-5005-00	6-32 NYLON STOP NUT	2
3	254-5000-14	NYLON SPACER - BLACK - 3/8 OD X .175 ID X 5/8"	2
4	830-5024-10	PLASTIC, POKÉMON, -10	1
5	830-5024-19	PLASTIC, POKÉMON, -19	1

### 5.65 PLASTIC 11 ASSEMBLY

511-3238-11

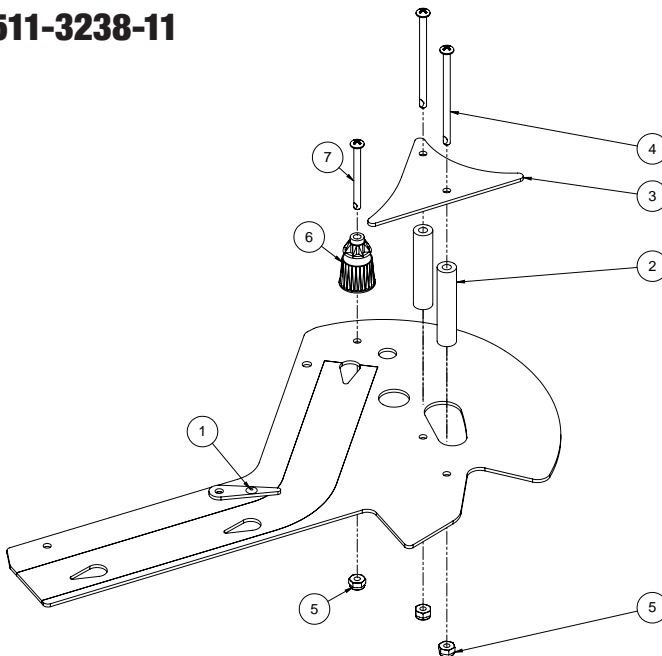

ID	Part Number	Description	Qty
1	510-2645-11	RIVETED PLASTIC ASSEMBLY -11, POKÉMON, PREM/LE	1
2	254-5000-17	NYLON SPACER - BLACK - 3/8 OD X .175 ID X 1-3/4"	2
3	830-5024-26	PLASTIC, POKÉMON, -26	1
4	237-5514-00P	SCREW, 6-32 X 2-1/4" PPH MS ZINC, PATCHED	2
5	240-5005-00	6-32 NYLON STOP NUT	3
6	550-5034-02	GROOVED JEWEL PLASTIC POST, RED	1
7	237-5510-00P	SCREW, 6-32 X 1-1/2" PPH MS, PATCH	1

### 5.66 PLASTIC 13 ASSEMBLY

511-3238-13

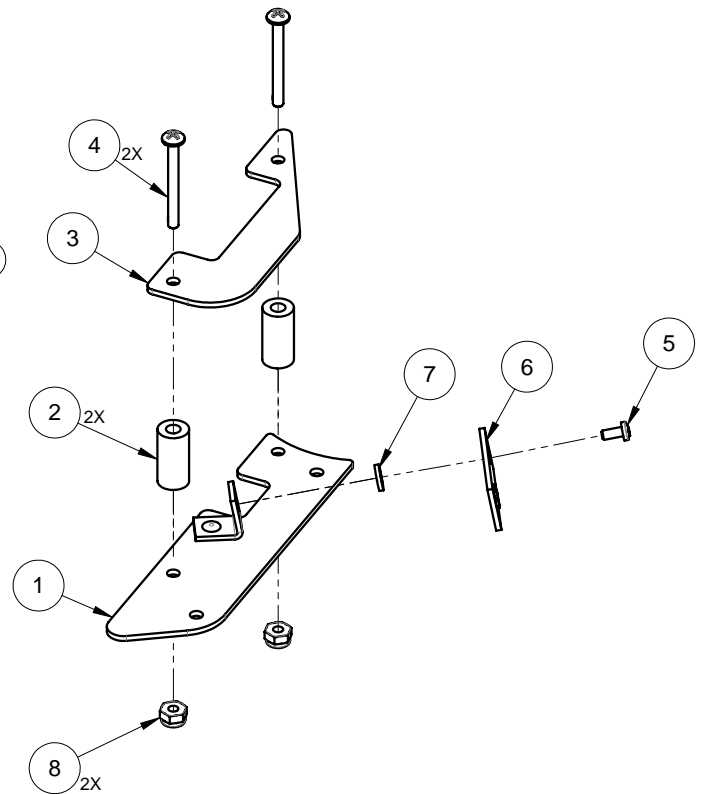

ID	Part Number	Description	Qty
1	510-2645-13	RIVETED PLASTIC ASSEMBLY -13, POKÉMON PREM/LE	1
2	254-5000-07	NYLON SPACER - BLACK - 3/8 OD X .175 ID X 3/4"	2
3	830-5024-21	PLASTIC, POKÉMON, -21	1
4	237-5508-00P	SCREW, 6-32 X 1-1/4 PPH MS, PATCH	2
5	237-6169-00P	SCREW, 4-40 X 1/4 PPH MS, PATCH	1
6	520-7000-00	SINGLE FLASH LED BOARD	1
7	242-5079-00	WASHER, .150 I.D. X .312 O.D. X .050 THICK	1
8	240-5005-00	6-32 NYLON STOP NUT	2



### 5.67 SUBWAY VUK ASSEMBLY

511-3672-00

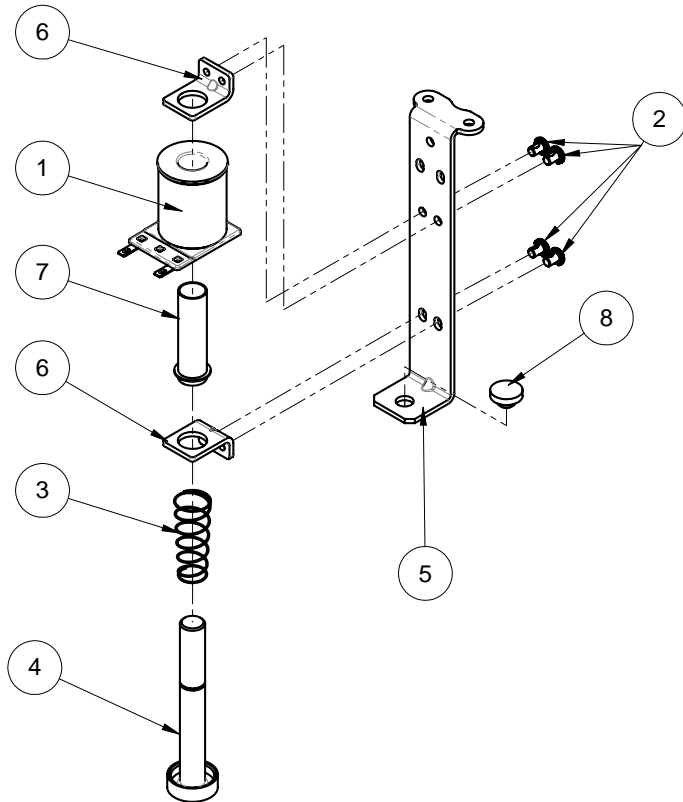

ID	Part Number	Description	Qty
1	090-5001-ND	COIL, 23-800, NO DIODE	1
2	232-5300-00P	SCREW, 8-32 X 1/4" PPH SEMS, PATCH	4
3	266-5020-00	COMPRESSION SPRING-CONICAL	1
4	515-7309-00	PLUNGER ASSEMBLY	1
5	535-4198-00	VUK BRACKET, POKÉMON	1
6	535-5203-03	COIL RETAINING BRACKET	2
7	545-5076-01	COIL SLEEVE	1
8	545-5105-00	RUBBER BUMPER	1

### 5.68 POKÉ BALL RAMP SUBWAY ASSEMBLY

511-4904-00

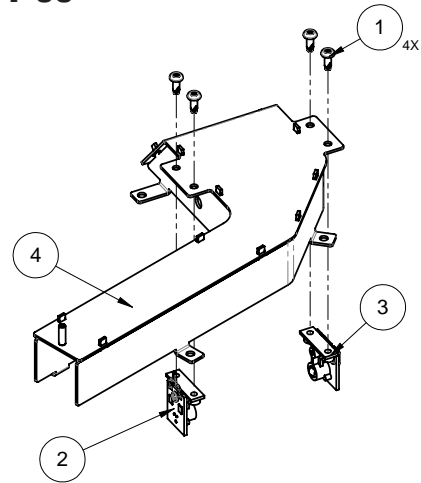

ID	Part Number	Description	Qty
1	237-5880-00	SCREW, #6 X 3/8 PPH T-25	4
2	515-0215-00	LONG RANGE OPTO EMITTER ASSEMBLY	1
3	515-0215-01	LONG RANGE OPTO RECEIVER ASSEMBLY	1
4	515-3038-00	SUBWAY, POKÉMON	1

## 5.69 POKÉ BALL RAMP ASSEMBLY 511-7965-00

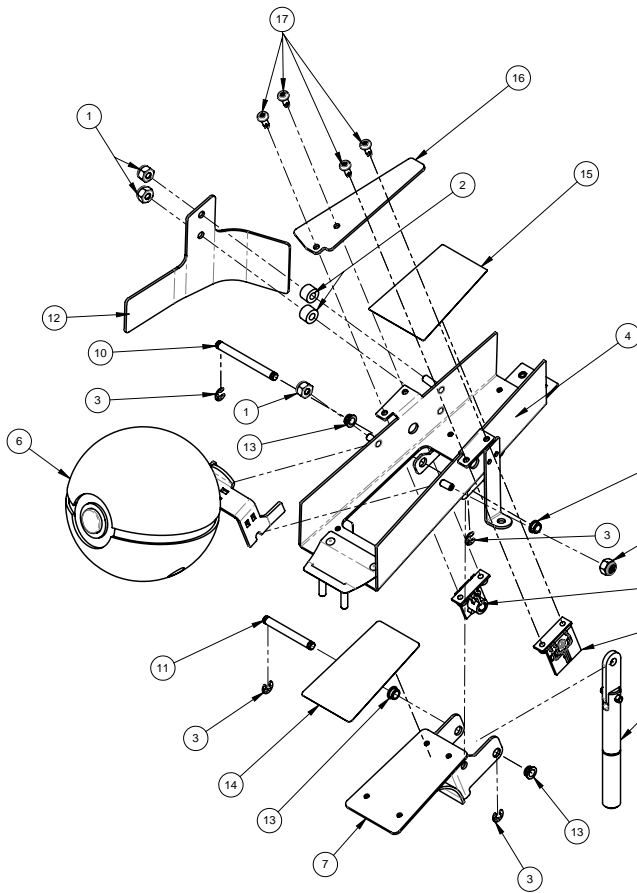

## 5.70 POKÉ BALL MECH ASSEMBLY 511-7965-01

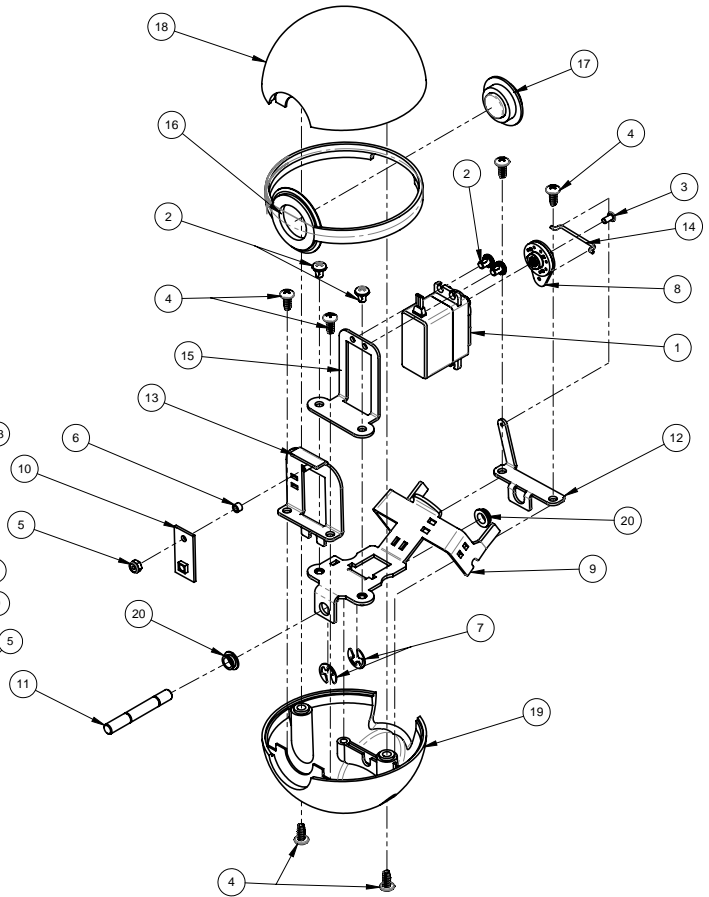

ID	Part Number	Description	Qty
1	240-5102-00	8-32 NYLON LOCK NUT	4
2	254-5000-09	NYLON SPACER - BLACK - 3/8 OD X .175 ID X 1/4"	2
3	270-5001-00	RETAINING E-RING, 3/16" SHAFT OD	4
4	510-8012-00	ASM RIVETED RAMP METAL LEFT, POKÉMON	1
5	511-1998-00	ASSEMBLY, PLUNGER, SPOT	1
6	511-7965-01	POKÉ BALL MECH ASSEMBLY, POKÉMON, PREM/LE	1
7	515-0017-02	TRAP DOOR, POKÉMON	1
8	515-0215-00	LONG RANGE OPTO EMITTER ASSEMBLY	1
9	515-0215-01	LONG RANGE OPTO RECEIVER ASSEMBLY	1
10	530-7812-00	PIVOT PIN-.188 DIA.	1
11	530-7812-02	PIVOT PIN-.188 DIA.	1
12	535-4187-21	BALL GUIDE, -21, POKÉMON	1
13	545-5352-00	NYLINER, 3/16" SHAFT	4
14	820-9313-10	DECAL, POKÉMON PREM/LE, -10	1
15	820-9313-11	DECAL, POKÉMON PREM/LE, -11	1
16	830-5024-20	PLASTIC, POKÉMON, -20	1
17	237-5880-00	SCREW, #6 X 3/8 PPH T-25	4

ID	Part Number	Description	Qty
1	041-5148-00	RC SERVO MOTOR	1
2	232-5300-00P	SCREW, 8-32 X 1/4" PPH SEMS, PATCH	4
3	237-6367-00	SCREW, M3 X 6MM, PPH, SERVO	1
4	237-6375-00	#8 X 1/2" PRH THREAD FORMING	6
5	240-5303-00	4-40 NYLON LOCK NUT	1
6	254-5090-03	PLASTIC SPACER #4 SCREW, 3/16" OD - 1/8" LENGTH	1
7	270-5002-00	RETAINING RING - 1/4"	2
8	511-4605-51	ASM, SERVO HORN, KONG BODY	1
9	515-0017-00	BALL MOUNT BRACKET, POKÉMON	1
10	520-5333-00	PCB - TRI-COLOR LED	1
11	530-9670-00	BALL PIVOT PIN, POKÉMON	1
12	535-0242-00	BALL LEVER ARM, POKÉMON	1
13	535-0242-01	BALL LIGHT MOUNT BKT, POKÉMON	1
14	535-0242-04	ROCKING WIRE	1
15	535-0242-05	BALL SERVO BRACKET, POKÉMON	1
16	544-0141-02	BALL RING POKÉ BALL	1
17	544-0141-03	BALL BUTTON POKÉ BALL	1
18	545-0141-00	PLAYFIELD POKÉ BALL, DECORATED	1
19	545-0141-01	BALL BOTTOM POKÉ BALL, DECORATED	1
20	545-5423-00	NYLINER, 1/4" SHAFT, 4L1-FF	2



## 5.71 ELECTRIC CONTROL GATE ASSEMBLY, LEFT MOUNT

511-5033-00

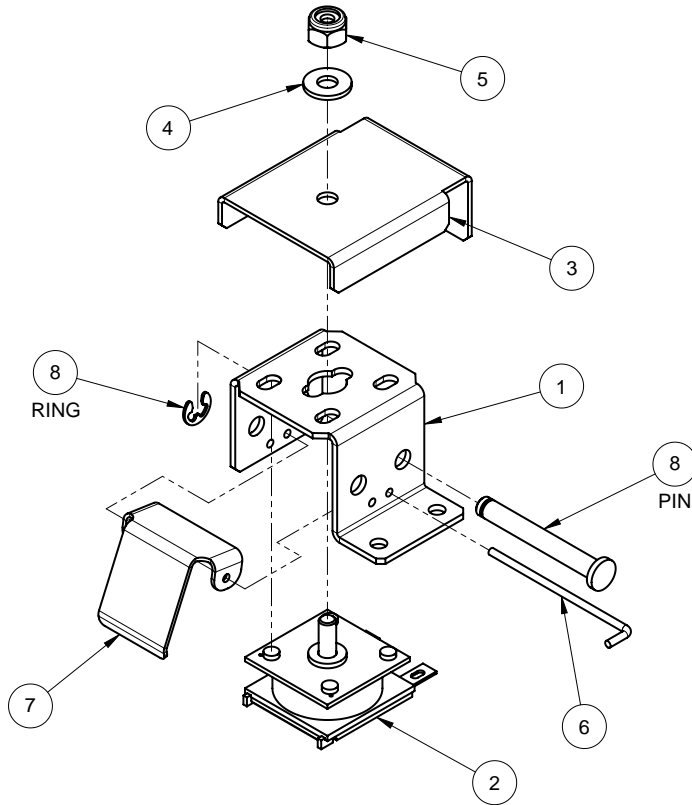

ID	Part Number	Description	Qty
1	535-9847-00	BRACKET, ELEC GATE, RAIL MOUNT	1
2	090-5060-01-ND	MINI COIL W/CORE - 32-1250, YELLOW	1
3	535-9577-00	COVER, ELECTRIC GATE	1
4	242-5005-00	#8 WASHER	1
5	240-5102-00	8-32 NYLON LOCK NUT	1
6	535-5372--00	REBOUND HINGE PIN	1
7	535-9682-00	GATE - ELECTRIC (MAGNET)	1
8	530-7201-01	CLEVIS PIN W/ RING, 3/16"D X 1-1/2"	1

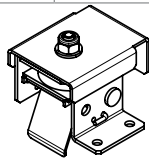

511-5033-00  
LEFT

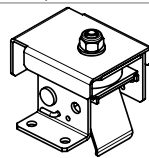

511-5033-01  
RIGHT

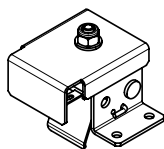

511-5033-02  
LEFT,  
REVERSED  
COVER

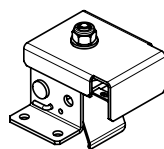

511-5033-03  
RIGHT,  
REVERSED  
COVER

## 5.72 MAGNET ASSEMBLY (ARENA)

500-7425-00

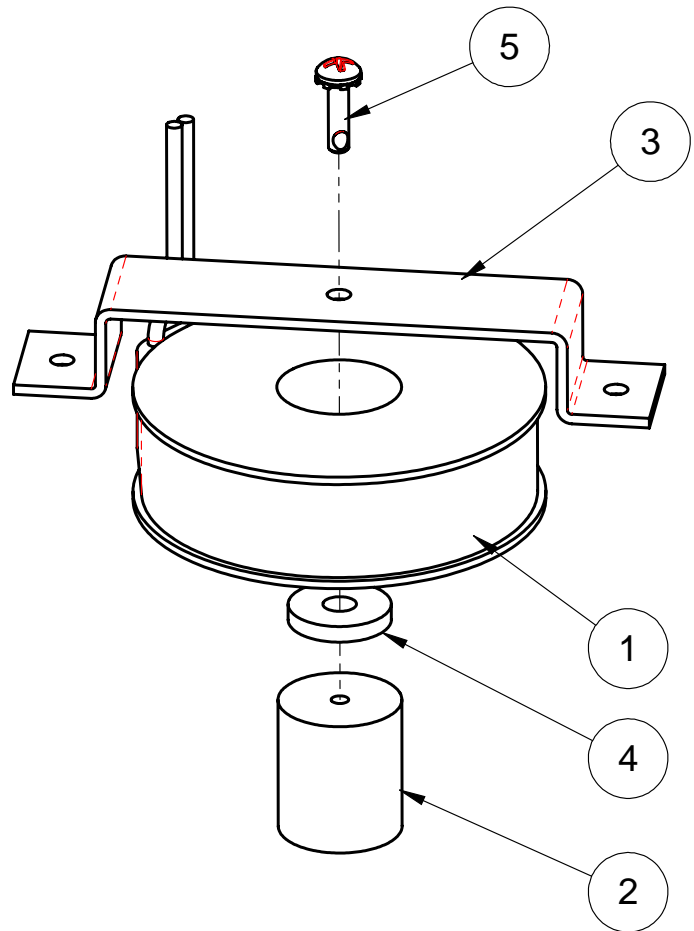

ID	Part Number	Description	Qty
1	511-5065-ND	MAGNET / CONNECTOR ASSY, 22-650	1
2	530-5266-01	MAGNET CORE	1
3	535-6637-01	MAGNET BRACKET	1
4	242-5039-00	WASHER - 13/64 ID X 5/8 OD X .105	1
5	232-5202-00P	SCREW, 6-32 X 1/2" PPH MS SEMS, PATCH	1

## 5.73 BACKPANEL ASSEMBLY

500-7930-00

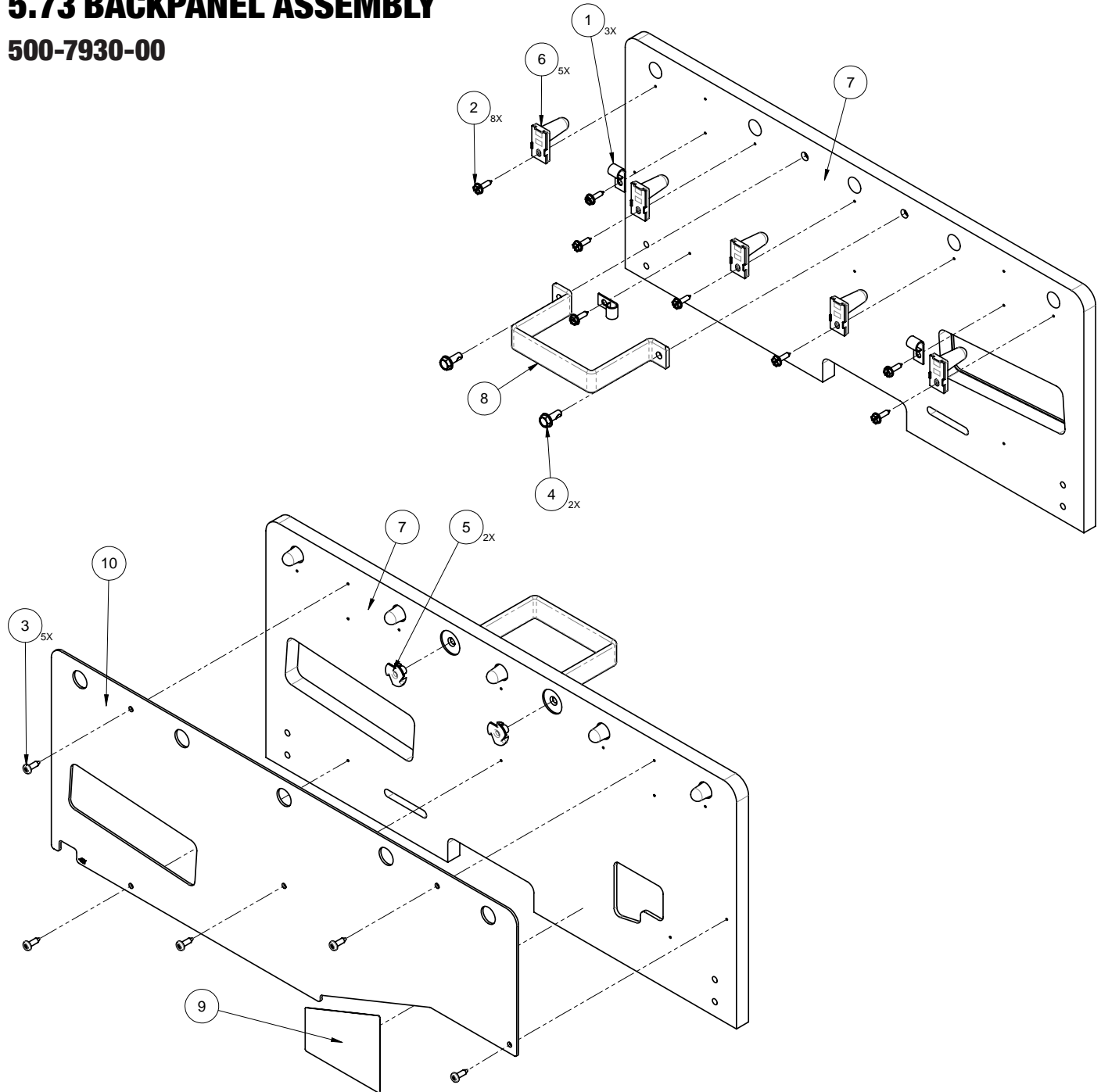

ID	Part Number	Description	Qty
1	040-5000-03	1/4" CABLE CLAMP	3
2	234-5001-02	SCREW, #6 X 1/2" HWH	8
3	237-5805-00	SCREW, #6 X 1/2" PPH AB BLACK	5
4	237-5995-00P	SCREW, 10-32 X 1/2" HWH SERR MS ZI, PATCH	2
5	240-5204-00	#10-32 T-NUT	2
6	511-3294-08	ASM, PCB GI, WHITE	5
7	525-9808-00	WOOD, BACK PANEL, POKÉMON	1
8	535-2288-00	HANDLE, BACKPANEL	1
9	820-9313-14	DECAL, POKÉMON PREM/LE, -14	1
10	830-5024-27	PLASTIC, POKÉMON, -27	1

# 6. SPECIFICATIONS

500-55AJ-01

## SPECIFICATIONS, MECHANICAL, GAME SETUP

Specification	Imperial	Metric
Weight	210 lbs	96 kg
Max dimensions, leg levers extended (h, w, d)	78 x 27.75 x 57 in	198 x 70.5 x 145 cm
Minimum game dimensions (h, w, d)	76 x 27.75 x 57 in	193 x 70.5 x 145 cm
Minimum room dimensions per game (h, w, d)	80 x 36 x 84 in	203 x 91 cm x 214 cm

- (h, w, d) = height, width, depth.

## SPECIFICATIONS, MECHANICAL, BOXED

Specification	Imperial	Metric
Weight, boxed (without pallet)	230 lbs	105 kg
Box dimensions (h, w, d)	56.5 x 31 x 31 in	144 x 79 x 79 cm
Minimum dimensions (h, w, d)	76 x 26 x 57 in	193 x 66 x 145 cm

- (h, w, d) = height, width, depth.

## SPECIFICATIONS, ELECTRICAL

Specification	North America - 120VAC	International - 240VAC
Line Voltage, Nominal	120 VAC	240 VAC
Line Voltage Range	90 VAC - 250 VAC	90 VAC - 250 VAC
Line Frequency *	60 Hz	50 Hz, 60 Hz
Line Power, Current - attract mode	70 W, 0.6 A @ 120 VAC	70 W, 0.3 A @ 240 VAC
Line Power, Current - nominal	360 W, 3 A @ 120 VAC	360 W, 1.5 A @ 240 VAC
Line Power, Current - peak, <100 ms	540 W, 4.5 A @ 120 VAC	540 W, 2.25 A @ 240 VAC

\* NOTE: Games designed for 60hz operation (e.g. North America games) will not function correctly on 50hz power and vice versa.

**WARNING:** Overloading electrical supply circuits is dangerous. Do not overload circuits. To calculate the maximum number of games for a circuit, check circuit amperage rating and divide by the game Nominal Line Power Current rating for your line voltage. For example, a 15A 120V household circuit, 15/3 A (nominal current) = 5 games maximum.

## SPECIFICATIONS, ENVIRONMENT

	Minimum	Maximum
Temperature, Operating	32 °F / 0 °C	104 °F / 40 °C
Temperature, Storage	32 °F / 0 °C	104 °F / 40 °C
Relative Humidity, Operating	5%	95% non-condensing
Relative Humidity, Storage	5%	95% non-condensing

- (a) "The appliance has to be placed in a horizontal position."
- (b) If the supply cord is damaged, it must be replaced by the manufacturer, its service agent or similarly qualified person in order to avoid hazard.

### 6.1 GAME DIMENSIONS

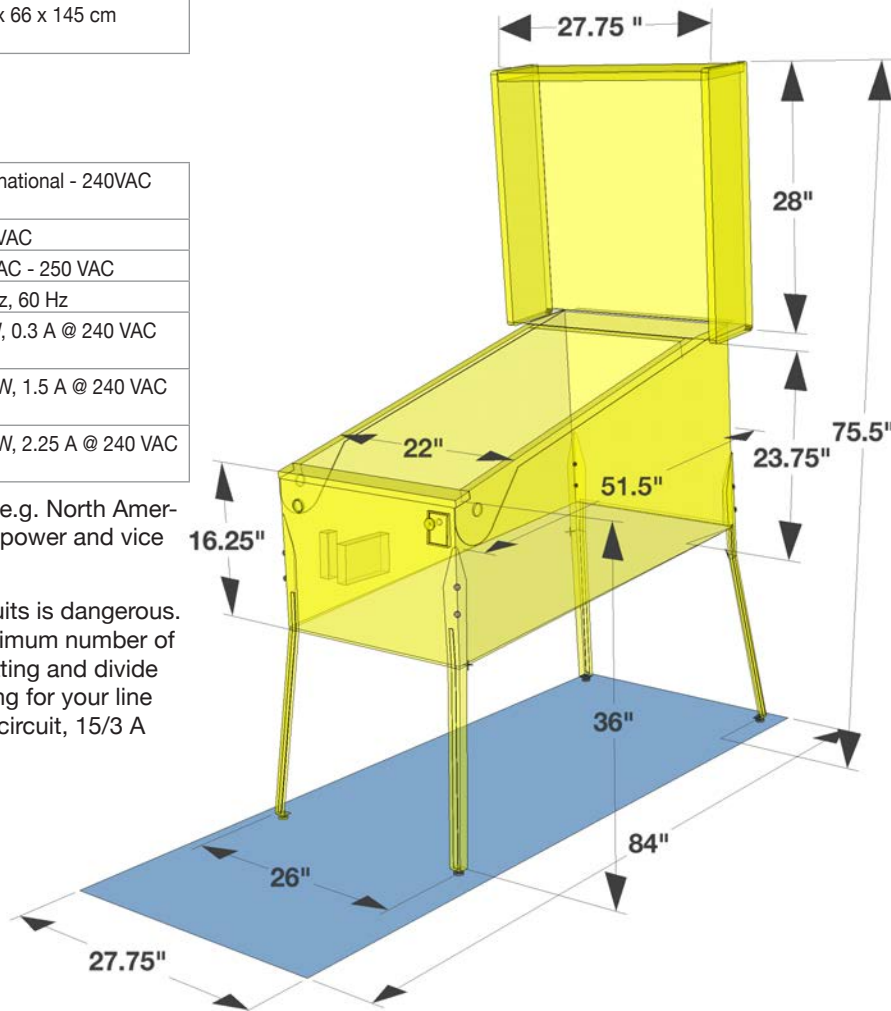

## 6.2 WARRANTY

Stern Pinball machines are assembled in Elk Grove Village, Illinois, USA; each pinball machine has unique characteristics that make it a one-of-a-kind American-made product. Each machine will have variations in appearance resulting from differences in the machine's particular wood parts, individual silk screened art and mechanical assemblies. Stern Pinball has inspected each game element to ensure it meets stringent quality and playability standards.

### STERN PINBALL INC LIMITED WARRANTY

For warranty information, please visit:

[sternpinball.com/support/warranty](http://sternpinball.com/support/warranty)

### ATTENTION! IMPORTANT WARRANTY INFORMATION

**The electronics system, node network architecture, mechanical devices and associated software control systems in this pinball machine are designed to work with genuine Stern Pinball accessories and devices.**

**Installation of non-authorized accessories, lamps, LED's, motors or other devices or modification of electro-mechanical devices may damage the system and may void your warranty.**

820-6617-00

## 6.3 WARNINGS, COMPLIANCE, AND LEGAL NOTICES

### PHOTOSENSITIVE SEIZURES HEALTH WARNING



A very small percentage of people may experience a seizure when exposed to certain visual images, including flashing lights or patterns. Even people with no history of seizures of epilepsy may have an undiagnosed condition that can cause "photosensitive epileptic seizures" due to certain visual images, flashing lights or patterns. Symptoms can include lightheadedness, altered vision, eye or face twitching, jerking or shaking of arms or legs, disorientation, confusion, momentary loss of awareness, and loss of consciousness or convulsions that can lead to injury from falling down or striking nearby objects.

IMMEDIATELY STOP PLAYING AND CONSULT A DOCTOR IF YOU EXPERIENCE ANY OF THESE SYMPTOMS.

### PARTS SUBSTITUTIONS



For safety and reliability, substitute parts and equipment modifications are not recommended and may void any and all warranties. Use of Non-Stern Pinball Inc Parts or Modifications of game circuitry may adversely affect game play or game safety. Transport pinball machines with hinged backbox in the down position only! Always take great care when servicing any game. Always read the service manual before replacing or servicing components. Substitutions of parts or equipment modifications may void FCC type acceptance.

Always disconnect the line voltage before servicing. Some parts may remain energized when unplugged. Take great caution when servicing any electrical components.

### FCC CLASS A SUBPART J COMPLIANCE



This equipment has been tested and found to comply with the limits for a Class A digital device, pursuant to part 15 of the FCC Rules. These limits are designed to provide reasonable protection against harmful interference when the equipment is operated in a commercial environment. This equipment generates, uses, and can radiate radio frequency energy and, if not installed and used in accordance with the instruction manual, may cause harmful interference to radio communications. Operation of this equipment in a residential area is likely to cause harmful interference in which case the user will be required to correct the interference at his own expense.

### RF INTERFERENCE NOTICE

The cable harness placements, ground strap routing, and other shielding have been designed to keep RF radiation and conduction within levels accepted by FCC rules. To maintain these levels, factory harness position, shielding, and ground straps must be installed in their factory locations should they become disconnected during maintenance.

### COPYRIGHT AND INTELLECTUAL PROPERTY NOTICE

This document and the data disclosed herein or herewith is not to be reproduced (Except where noted), used, or otherwise disclosed in whole or in part to anyone without written consent of Stern Pinball Inc.

Products in this manual, the company name and devices and the design of the manual itself are protected by federal patents (and patents pending), design registrations, trademarks, and copyrights. Action will be taken in the event of infringement or imitation. The right is reserved to change specifications without prior notice.



### 6.4 STERN PINBALL END USER LICENSE AGREEMENT

This limited software license Agreement (“Agreement”) applies to your use of Stern Pinball Software pre-installed on a Stern Pinball Machine and any Authorized Updates made available to you.

**BY USING YOUR STERN PINBALL MACHINE, YOU AGREE TO THE TERMS OF THIS AGREEMENT.** If you do not agree to the terms of this Agreement, do not use your Stern Pinball Machine or any Authorized Updates. Please read this entire Agreement, which governs your use of the Stern Pinball Machine, Stern Pinball Software and all Authorized Updates.

#### ADULT CONSENT

TO ENTER INTO THIS AGREEMENT, YOU MUST BE AN ADULT OF THE LEGAL AGE OF MAJORITY IN YOUR COUNTRY OF RESIDENCE. YOU ARE LEGALLY AND FINANCIALLY RESPONSIBLE FOR ALL ACTIONS USING YOUR STERN PINBALL MACHINE AND SOFTWARE AND ACCESSING OR USING ANY ONLINE GAMING PLATFORM, INCLUDING THE ACTIONS OF ANYONE YOU ALLOW TO USE AND ACCESS TO YOUR MACHINE AND ANY ASSOCIATED ACCOUNT. YOU AFFIRM THAT YOU HAVE REACHED THE LEGAL AGE OF MAJORITY, UNDERSTAND AND ACCEPT THIS AGREEMENT. IF YOU ARE UNDER THE LEGAL AGE OF MAJORITY, YOUR PARENT OR LEGAL GUARDIAN MUST CONSENT TO THIS AGREEMENT.

#### DEFINITIONS

- a. “Stern Pinball Machine” means a Stern Pinball arcade game machine.
- b. “Stern Pinball Software” means software (including but not limited to firmware) pre-installed in the Stern Pinball Machine, including all Authorized Content and any Authorized Updates that Stern Pinball may make available to You from time to time.
- c. “Authorized Content” means all Stern Pinball and third-party owned software and content incorporated into or used with the Stern Pinball Software or otherwise embedded in or utilized by a Stern Pinball Machine, including but not limited to graphics, images, music, vocals and voices.
- d. “Authorized Update” means an update to the Stern Pinball Software distributed by Stern Pinball or otherwise made available by Stern Pinball, including for download on its website.
- e. “Unauthorized Content” means all content, including but not limited to graphics, images, music, vocals and voices, that does not comprise Authorized Content or an Authorized Update.
- f. “Unauthorized Software” means any software (including but not limited to firmware) not pre-installed by Stern Pinball on a Stern Pinball Machine or that does not comprise Authorized Content or Authorized Update.
- g. “You” means the purchaser or current owner of a Stern Pinball Machine.

#### LICENSE

Stern Pinball hereby grants You a nonexclusive, non-transferable, limited, and revocable right and license to use one copy of the Stern Pinball Software and Authorized Content and any Authorized Update solely for your personal use, or that of your patrons and customers if you are a commercial entity, for playing a single Stern Pinball Machine. The Stern Pinball Software, Authorized Content and Authorized Updates are licensed, not sold, to You, and no ownership rights are transferred by this Agreement. The Stern Pinball Software Authorized Content and Authorized Updates are protected by U.S. and international copyright. All rights not explicitly granted to you in this Agreement are reserved by Stern Pinball.

- a. As a condition to this Stern Pinball Software license, You agree that:
  - i. You will not copy, reproduce, alter, replace, distribute, reverse engineer, decompile, disassemble, display, perform, create derivative works based on, or otherwise modify the Stern Pinball hardware or Stern Pinball Software or any Authorized Update, in whole or in part; and will not commercially exploit any of the foregoing.
  - ii. **You will not use or install any Unauthorized Content or Unauthorized Software. Use of Unauthorized Content or Unauthorized Software may result in your Stern Pinball Machine ceasing to work permanently and/or losing access to Stern Pinball’s online game network, either immediately or after a later installed Authorized Update.**

- iii. **You will not create, develop, distribute or assist anyone else in creating, developing or distributing any Unauthorized Content or Unauthorized Software intended for use with a Stern Pinball Machine, whether to add to or modify the gameplay, any audio content (whether music, sound or voice), or any video content of any Stern Pinball Machine, or to gain advantage in any online or other game modes, or otherwise.**
- iv. You will not share any Stern Pinball Software, Authorized Content or Authorized Update with any other person or company and will not permit anyone else to access or copy any Stern Pinball Software or Authorized Content or Authorized Update installed on your Machine for any purpose.
- v. In view of the rights held by third-party owners of Authorized Content (e.g., music and video clips), Stern does not have the legal authority to give permission to stream the gameplay of Stern Pinball Machines.
- vi. You will not (i) attempt to defeat or circumvent any anti-piracy, security, and/or technical measures to control access to the Stern Pinball Software, features, functions or content, (ii) allow unauthorized use, or (iii) otherwise allow anyone from exceeding the limited license rights granted under this Agreement, "Security Measures". Attempting to defeat or circumvent any Security Measure may result in your Stern Pinball Machine ceasing to work permanently either immediately or after a later installed Authorized Update.
- vii. **Stern Pinball may update the Stern Pinball Software from time to time without further notice to You, for example, to update any anti-piracy, security, and technical measure.**

## PRIVACY POLICY

Your use of the Stern Pinball Machine, Stern Pinball Software and any Authorized Updates is subject to Stern Pinball's Privacy Policy which can be found at <https://sternpinball.com/privacy-policy>.

## WARRANTY

EXCEPT AS PROVIDED HEREIN, THE STERN PINBALL SOFTWARE, AUTHORIZED CONTENT AND AUTHORIZED UPDATES ARE PROVIDED "AS IS" AND, TO THE MAXIMUM EXTENT ALLOWABLE UNDER LAW, STERN PINBALL DISCLAIMS ALL WARRANTIES OF ANY KIND, WHETHER EXPRESS OR IMPLIED, INCLUDING BUT NOT LIMITED TO ANY WARRANTIES OF MERCHANTABILITY, FITNESS FOR A PARTICULAR PURPOSE, AND NONINFRINGEMENT. WITHOUT LIMITING THE FOREGOING, STERN PINBALL DOES NOT WARRANT THAT OPERATION OF THE STERN PINBALL MACHINE OR ANY ONLINE OR CONNECTED GAME NETWORK WILL BE UNINTERRUPTED OR ERROR-FREE.

## EXCLUSION OF CERTAIN DAMAGES

STERN PINBALL IS NOT RESPONSIBLE FOR ANY DIRECT, INDIRECT, INCIDENTAL, SPECIAL, OR CONSEQUENTIAL DAMAGES; ANY LOSS OF DATA, PRIVACY, CONFIDENTIALITY, OR PROFITS; OR ANY INABILITY TO USE THE STERN PINBALL MACHINE, STERN PINBALL SOFTWARE OR ANY AUTHORIZED UPDATE. THESE EXCLUSIONS APPLY EVEN IF STERN PINBALL HAS BEEN ADVISED OF THE POSSIBILITY OF THESE DAMAGES, AND EVEN IF ANY REMEDY FAILS OF ITS ESSENTIAL PURPOSE. Some countries do not allow the exclusion or limitation of incidental or consequential damages, so this limitation or exclusion may not apply to You.

These terms apply to the maximum extent permitted by law and unless prohibited by law. These terms do not change your rights under the laws of your country if those laws do not permit that change.

## TERRITORY AND CHOICE OF LAW

This License is valid only in the country in which you purchased your Stern Pinball Machine. This License will be subject to and construed in accordance with the laws of the State of Illinois, U.S.A., regardless of conflict of laws principles. You agree to submit to the exclusive jurisdiction of the state and federal courts in Cook County, Illinois, U.S.A. for the resolution of any dispute regarding this Agreement or the subject matter of this Agreement and to waive any jurisdictional, venue, or inconvenient forum objections to such courts.

This Agreement may be updated by Stern Pinball from time to time with the current version posted at [www.sternpinball.com/EULA](http://www.sternpinball.com/EULA). Your continued use of the Stern Pinball Software and Authorized Update after an updated Agreement has been posted constitutes your acceptance of all of its terms.





**POKÉMON**™

**1-800-KICKERS**  
[SERVICE@STERNPINBALL.COM](mailto:SERVICE@STERNPINBALL.COM)  
[WWW.STERNPINBALL.COM](http://WWW.STERNPINBALL.COM)  
[FACEBOOK.COM/STERNPINBALL](https://FACEBOOK.COM/STERNPINBALL)

POKÉMON LE #500-55AJ-01  
POKÉMON PREMIUM #500-55AH-01  
MANUAL #780-50AJ-00

